



by Unverferth

All Terrain
Injection
Liquid Applicator



AT4615

Beginning with Serial Number A66640100

Part No. 45006

Foreword

 This symbol identifies important safety messages. When you see it, read the message that follows and be alert to the possibility of personal injury.

Remember, safety instructions stated in this manual are for your protection. Read them carefully and follow them closely when working around or using this machine.

Read and study this manual completely before attempting to operate this implement. Take this manual to the field for handy reference when operating, adjusting, or servicing your machine.

When referenced, “Right-Hand” (RH) and “Left-Hand” (LH) side of the machine are determined by standing behind the machine and facing in the direction of travel.

Pre-Delivery Checklist

- Hardware tightened
- Machine lubricated
- Safety and operating procedures reviewed
- Field adjustment information reviewed
- Warranty information reviewed

IMPORTANT

The information, specifications, and illustrations in the manual are based on the information available at the time it was written. Due to continuing improvements in the design and manufacture of Unverferth products, all specifications and information contained herein are subject to change without notice.

Product Information

When ordering parts or when requesting further information or assistance, always give the following information:

- Machine name
- Model
- Serial number

All products manufactured by Unverferth are warranted to be free from material and workmanship defects for one full year from time of consumer delivery. Your local dealer will gladly assist you with any warranty questions.

Please fill out and retain this portion for your records.

Purchase Date _____ Model _____ Serial Number _____

Dealer _____ City _____

Dealer Contact _____ Phone _____

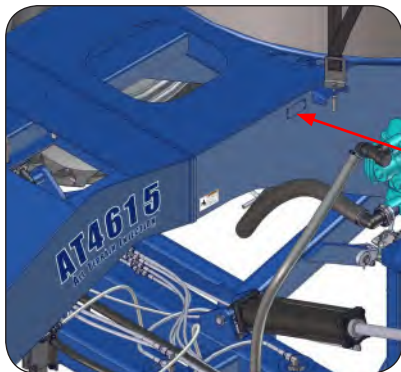

The Serial Number is located on the left-hand side behind the tongue pull plate.

TABLE OF CONTENTS

Foreword 2
Pre-Operation Checklist 2

SECTION I
Safety

General Hazard Information 1-2
Safety Decals 1-3
Following Safety Instructions 1-5
Before Servicing 1-5
Before Operating 1-6
During Operation 1-6
Before Transporting 1-7
During Transport 1-7
Pressurized Oil 1-8
Chemical Hazards 1-8
Clean Water Tank 1-9
Preparing for Emergencies 1-10
Wearing Protective Equipment 1-10

SECTION II
Set Up

General Set Up Information 2-2
Unloading Applicator from Shipping Trailer 2-3
 Tongue Assembly to Main Frame Assembly 2-3
Main Frame Transportation Wheels 2-6
Pump Drive 2-7
Coulter Assembly 2-8
Gauge Wheel Assembly 2-8
Transport Lighting Assembly 2-8
Pump Set Up - For Units with Centrifugal Pump 2-9
 Setting the Pump Pressure (non-PWM Pump) 2-9
Rate Orifice Installation 2-10
Overhead Layouts 2-11

TABLE OF CONTENTS

SECTION III
Operation

Preparing Tractor	3-2
Preparing Applicator.....	3-2
Hardware.....	3-2
Pivot Pins	3-2
Hitch	3-2
Hydraulic System.....	3-2
Tires/Wheels.....	3-3
Lubrication	3-3
Leveling Machine.....	3-3
Hitching to the Tractor.....	3-4
Drawbar Hitching.....	3-4
Transport Chain	3-5
Hydraulic Connections.....	3-6
Applicator Solution Pump Hydraulics - For Units with Centrifugal Pump Option	3-7
Electrical Connection	3-7
Jack Usage.....	3-8
Parked Position.....	3-8
Transport Position	3-8
Transporting	3-9
Drawbar Connection	3-9
Bottom Fill Valve Operation.....	3-10
Clean Water Tank.....	3-10
Unfolding Toolbar.....	3-11
Adjusting Toolbar Flex	3-13
Depth Adjustment	3-14
Folding Toolbar.....	3-15

TABLE OF CONTENTS

SECTION IV
Maintenance

Applicator Maintenance.....	4-2
Seasonal Storage.....	4-2
Purging A Hydraulic System.....	4-3
Lubrication	4-4
Filters.....	4-6
Primary Filter.....	4-6
Secondary Filter.....	4-6
Winterizing	4-7
High-Pressure Coulter Injection System Nozzle Calibration Worksheet	4-8
Schematics.....	4-10
Wheel, Hub and Spindle Disassembly and Assembly.....	4-15
Wheels and Tires.....	4-17
Wheel Nut Torque Requirements.....	4-17
Tire Pressure	4-18
Tire Warranty.....	4-18
Complete Torque Chart	
Grade 5	4-19
Grade 8	4-20
Hydraulic Fittings.....	4-21
Manifold Layouts.....	4-22

TABLE OF CONTENTS

SECTION V
Parts

AT4615 Main Frame 5-2

Hitch, Transport Chain, Manual Holder and Jack Components 5-4

Decals 5-6

Clean Water Tank Components 5-8

Wheel/Axle, 120" Single, 380/90R46 5-9

Hub and Spindle Components 5-10

Double Tube Toolbar - Center Section & Gull Wing Components 5-12

Single Tube Toolbar - Center Section & Gull Wing Components 5-13

Primary Wing Components (Double Tube Toolbar) 5-14

Primary Wing Components (Single Tube Toolbar) 5-16

Secondary Wing Components (Double Tube Toolbar) 5-18

Secondary Wing Components (Single Tube Toolbar) 5-20

Third Wing Components (Double Tube Toolbar) 5-22

Wing Extension Components (Single Tube Toolbar) 5-24

Coulter Offset Mounting Bracket, 10" x 4" (JAAM2180) 5-25

Coulter Offset Mounting Bracket, 15" x 4" (JAAM2721) 5-26

Coulter 45° Angled Mounting Bracket (JAAM2436) 5-27

Coulter Flatback Centered Mounting Bracket (JAAM2821) 5-28

Coulter Flatback Centered Mounting Bracket (JAAM2646) 5-29

Coulter Flatback Offset Mounting Bracket (JAAM2822) 5-30

Offset Mounting Bracket, 45" x 4" (JAAM2737) 5-31

Offset Mounting Bracket, 25" x 4" (JAAM2739) 5-32

Stagger Flatback Spacer (JAAM2740) 5-32

Bolt-On Coulter Bar Assembly (JAAM2908) 5-33

Gauge Wheel Legs RH/LH Pair, Vertical Pin Adjust 5-34

Super 1200 Coulter Assembly Components (JAAM2730) 5-36

Coulter Arm, Hub & Knee Components (JAM2799) 5-37

Hub Assembly, 4-Bolt Components (JAP2707) 5-38

Coulter Blade (JAP2840) 5-39

Narrow Fold Transport Coulter Option (43468) (Double Tube Toolbar) 5-40

Narrow Fold Transport Coulter Option (43679) (Single Tube Toolbar) 5-42

Jetstream Coulter Knife Assembly Components (JAAM3356) 5-44

Jetstream Liquid Assembly Components; Tee-Jet Check (JAAM3353); Low Rate (JAAM3355) 5-46

Lighting Components - For 15, 20, & 30" Spacing 4-48

Lighting Components - For 18" Spacing 4-50

Hitch Hydraulic Components (Double Tube Toolbar) 5-52

Hitch Hydraulic Components (Single Tube Toolbar) 5-54

Double Tube Toolbar Gull Wing & Relief Valve Hydraulic Components 5-56

Single Tube Toolbar Gull Wing & Relief Valve Hydraulic Components 5-58

Primary Wing Hydraulic Components (Double Tube Toolbar) 5-60

Primary Wing Hydraulic Components (Single Tube Toolbar) 5-61

Toolbar Lift Hydraulic Components (Double Tube Toolbar) 5-62

Toolbar Lift Hydraulic Components (Single Tube Toolbar) 5-64

Secondary Wing Hydraulic Components (Double Tube Toolbar) 5-65

Secondary Wing Hydraulic Components (Single Tube Toolbar) 5-66

Third Wing Hydraulic Components (Double Tube Toolbar) 5-67

(Continued)

TABLE OF CONTENTS

SECTION V
Parts (continued)

Single & Double Pump Drive Components5-68
Pump Drive Package (JPKG00181)5-70
40 Tooth Sprocket & Roller Chain Components.....5-72
50 Tooth Sprocket & Roller Chain Components.....5-73
Bottom Filling Plumbing Components.....5-74
ACE 205 Variable Rate Pump5-76
Ball Valve Components5-79
Manifold Components5-80
Manifold Components — Gauge & Mounting Components.....5-82
Manifold Layout—Drive Pump, Fittings & Hoses (Center Section w/Double Tube Frame).....5-84
Manifold Layout—Drive Pump, Fittings & Hoses (Center Section w/Single Tube Frame).....5-86
Manifold Layout — 23 Row Coulter Assembly Fittings and Hoses5-88
Manifold Layout — 25 Row Coulter Assembly Fittings and Hoses5-90
Controller Components..... 5-92

SECTION I
Safety

General Hazard Information 1-2
Safety Decals..... 1-3
Following Safety Instructions..... 1-5
Before Servicing 1-5
Before Operating..... 1-6
During Operation..... 1-6
Before Transporting..... 1-7
During Transport 1-7
Pressurized Oil..... 1-8
Chemical Hazards 1-8
Clean Water Tank..... 1-9
Preparing for Emergencies 1-10
Wearing Protective Equipment..... 1-10

General Hazard Information

No accident-prevention program can be successful without the wholehearted cooperation of the person who is directly responsible for the operation of the equipment.

A large number of accidents can be prevented only by the operator anticipating the result before the accident is caused and doing something about it. No power-driven equipment, whether it be transportation or processing, whether it be on the highway, in the field, or in the industrial plant, can be safer than the person who is at the controls. If accidents are to be prevented--and they can be prevented--it will be done by the operators who accept the full measure of their responsibility.

It is true that the designer, the manufacturer, and the safety engineer can help; and they will help, but their combined efforts can be wiped out by a single careless act of the operator.

It is said that, "the best kind of a safety device is a careful operator." We, at Unverferth Mfg. Co., Inc. ask that you be that kind of operator.



REMEMBER:
THINK SAFETY
A CAREFUL OPERATOR IS THE
BEST INSURANCE AGAINST AN
ACCIDENT!

SIGNAL WORDS



INDICATES AN EXTREMELY HAZARDOUS SITUATION OR ACTION THAT WILL RESULT IN SERIOUS INJURY OR DEATH.



INDICATES A HAZARDOUS SITUATION OR ACTION THAT COULD RESULT IN SERIOUS INJURY OR DEATH.



INDICATES AN UNSAFE SITUATION OR ACTION THAT MAY RESULT IN PERSONAL INJURY.



Is used for instruction on operating, adjusting, or servicing a machine.

Safety Decals

WARNING

- REPLACE LOST, DAMAGED, PAINTED, OR UNREADABLE DECALS IMMEDIATELY. IF PARTS THAT HAVE DECALS ARE REPLACED, ALSO MAKE SURE TO INSTALL NEW DECALS. THESE DECALS INFORM AND REMIND THE OPERATOR WITH OPERATIONAL INFORMATION AND SAFETY MESSAGES.

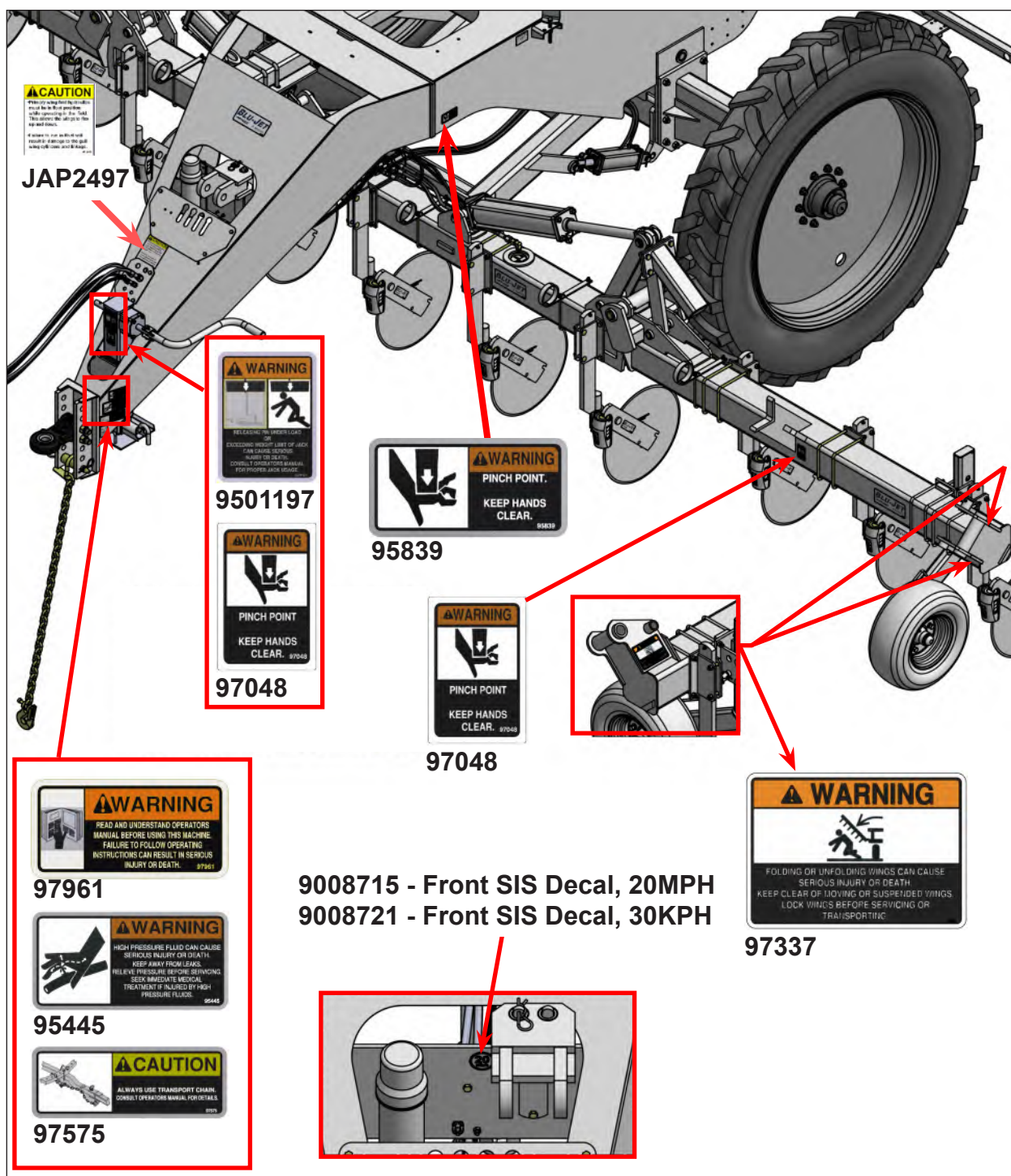

(Continued)



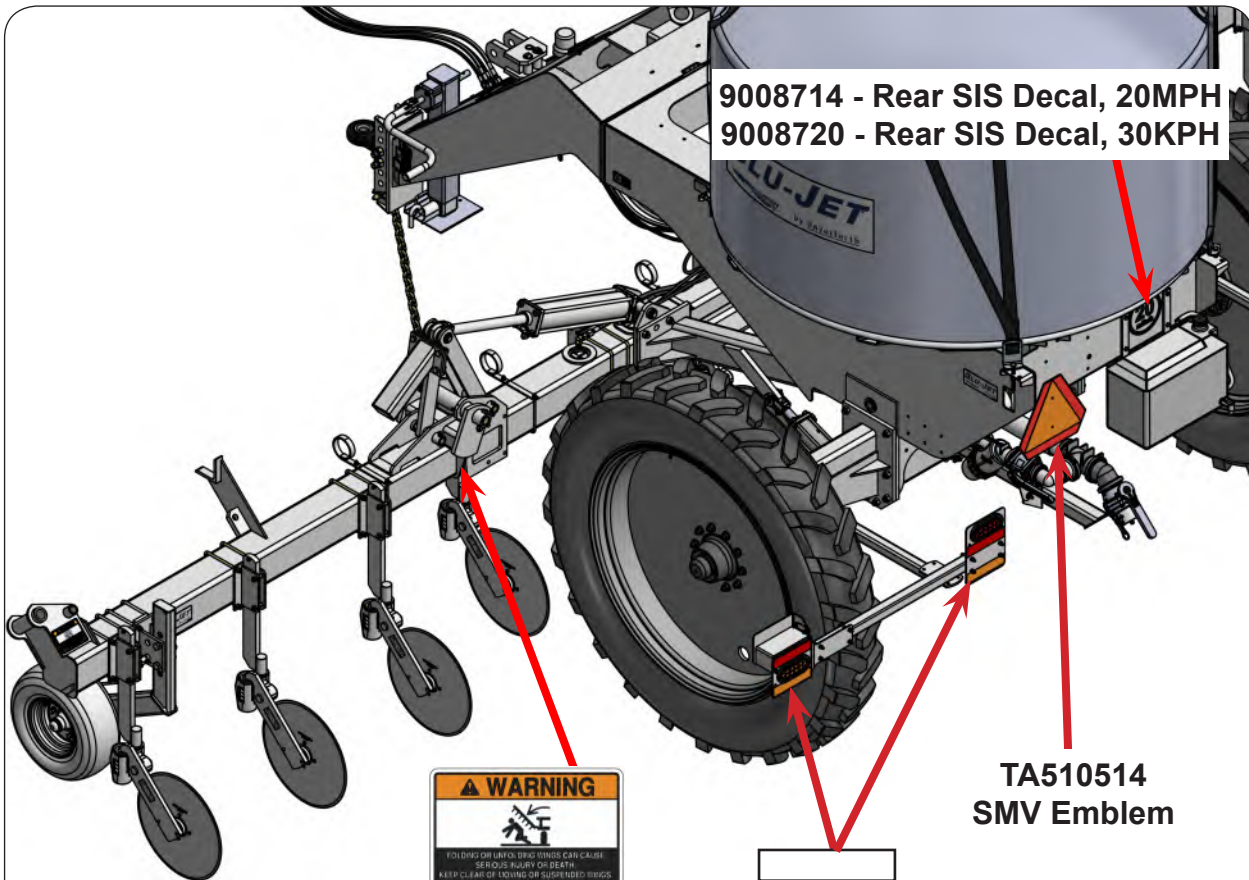

Safety Decals (continued)

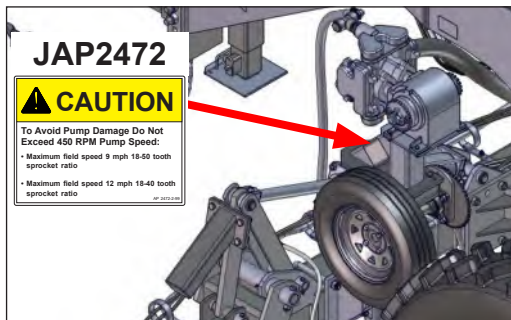

97337 - On Bottom Of Wings



Following Safety Instructions

- Read and understand this operator's manual before operating. 
- All machinery should be operated only by trained and authorized personnel.
- To prevent machine damage, use only attachments and service parts approved by the manufacturer.
- Always shut tractor engine off and remove key before servicing. 
- Avoid personal attire such as loose fitting clothing, shoestrings, drawstrings, pants cuffs, long hair, etc., that may become entangled in moving parts.
- Do not allow anyone to ride on the implement. Make sure everyone is clear before operating machine or towing vehicle. 
- Never attempt to operate implement unless you are in driver's seat. 

Before Servicing

- Avoid working under an implement; however, if it becomes absolutely unavoidable, make sure the implement is safely blocked. 
- Ensure that all applicable safety decals are installed and legible.
- When working around the implement, be careful not to be cut by sharp edges.
- Explosive separation of a tire and rim can cause serious injury or death. Only properly trained personnel should attempt to service a tire and wheel assembly.
- Add sufficient ballast to tractor to maintain steering and braking control at all times. Do not exceed tractor's lift capacity or ballast capacity.
- Hitch applicator to towing vehicle and clear all personnel from the surrounding area before folding and unfolding wings.
- Check all applicator equipment for leaks. Repair any leaks before beginning or resuming operation.
- Residual pressure may exist in applicator plumbing even when unit is not in use. Remove pressure before servicing any plumbing.

Before Operating

- Do not stand between towing vehicle and implement during hitching.
- Always make certain everyone and everything is clear of the machine before beginning operation.
- Verify that all safety shields are in place and properly secured.
- Ensure that all applicable safety decals are installed and legible.
- When working around the implement, be careful not to be cut by sharp edges.
- Add sufficient ballast to tractor to maintain steering and braking control at all times. Do not exceed tractor's lift capacity or ballast capacity.
- This applicator is intended to apply only agricultural chemicals. Attempting to apply other liquids may cause equipment damage and introduce unexpected personal hazards.
- Hitch applicator to towing vehicle and clear all personnel from the surrounding area before folding and unfolding wings.
- Residual pressure may exist in applicator plumbing even when unit is not in use. Remove pressure before servicing any plumbing.

During Operation

- Regulate speed to field conditions. Maintain complete control at all times.
- Never service or lubricate equipment when in operation.
- Keep away from overhead power lines. Electrical shock can cause serious injury or death.
- Use extreme care when operating close to ditches, fences, or on hillsides.
- Do not leave towing vehicle unattended with engine running.

Before Transporting

- Secure transport chains to towing vehicle before transporting. **DO NOT** transport without chains.
- Install transport locks before transporting.
- Check for proper function of all available transport lights. Make sure that all reflectors are clean and in place on machine. Make sure that the SMV emblem and SIS decal are visible to approaching traffic.
- This implement may not be equipped with brakes. Ensure that the towing vehicle has adequate weight and braking capacity to tow this unit.

During Transport

- Comply with all laws governing highway safety when moving machinery.
- Use transport lights as required by all laws to adequately warn operators of other vehicles.
- Use good judgment when transporting equipment on highways. Regulate speed to road conditions and maintain complete control.
- Maximum transport speed of this implement should never exceed 20 mph as indicated on the machine. Maximum transport speed of any combination of implements must not exceed the lowest specified speed of the implements in combination. Do not exceed 10 mph during off-highway travel.
- Slow down before making sharp turns to avoid tipping. Drive slowly over rough ground and side slopes.
- It is probable that this implement is taller, wider and longer than the towing vehicle. Become aware of and avoid all obstacles and hazards in the travel path of the equipment, such as power lines, ditches, etc.

Pressurized Oil

- Relieve the hydraulic system of all pressure before adjusting or servicing. See hydraulic power unit manual for procedure to relieve pressure.
- High-pressure fluids can penetrate the skin and cause serious injury or death. Use cardboard or wood to detect leaks in the hydraulic system. Seek medical treatment immediately if injured by high-pressure fluids.
- Hydraulic system must be purged of air before operating to prevent serious injury or death.
- Do not bend or strike high-pressure lines. Do not install bent or damaged tubes or hoses.
- Repair all oil leaks. Leaks can cause fires, personal injury, and environmental damage.
- Route hoses and lines carefully to prevent premature failure due to kinking and rubbing against other parts. Make sure that all clamps, guards and shields are installed correctly.
- Check hydraulic hoses and tubes carefully. Replace components as necessary if any of the following conditions are found:
 - o End fittings damaged, displaced, or leaking.
 - o Outer covering chafed/cut or wire reinforcing exposed.
 - o Outer covering ballooning locally.
 - o Evidence of kinking or crushing of the flexible part of a hose.



Chemical Hazards



- Always wear personal protective equipment when working with or near chemicals. This equipment includes, but is not limited to: protective eye wear, gloves, shoes, socks, long-sleeved shirt, and long pants. Additional protection may be required for many types of chemicals.
- Seek and receive chemical product training prior to using agricultural chemicals.
- Read and understand the entire label of every chemical being applied with this applicator.
- Avoid breathing applicator mist or vapor.
- Wash hands and exposed skin immediately after contact with spray/fertilizer solution and application equipment.
- Remove clothing immediately if chemicals penetrate clothing and contact skin. Wash thoroughly and put on clean clothing.
- Dispose of unused chemical in accordance with chemical label directions and local/national regulations.

Clean Water Tank

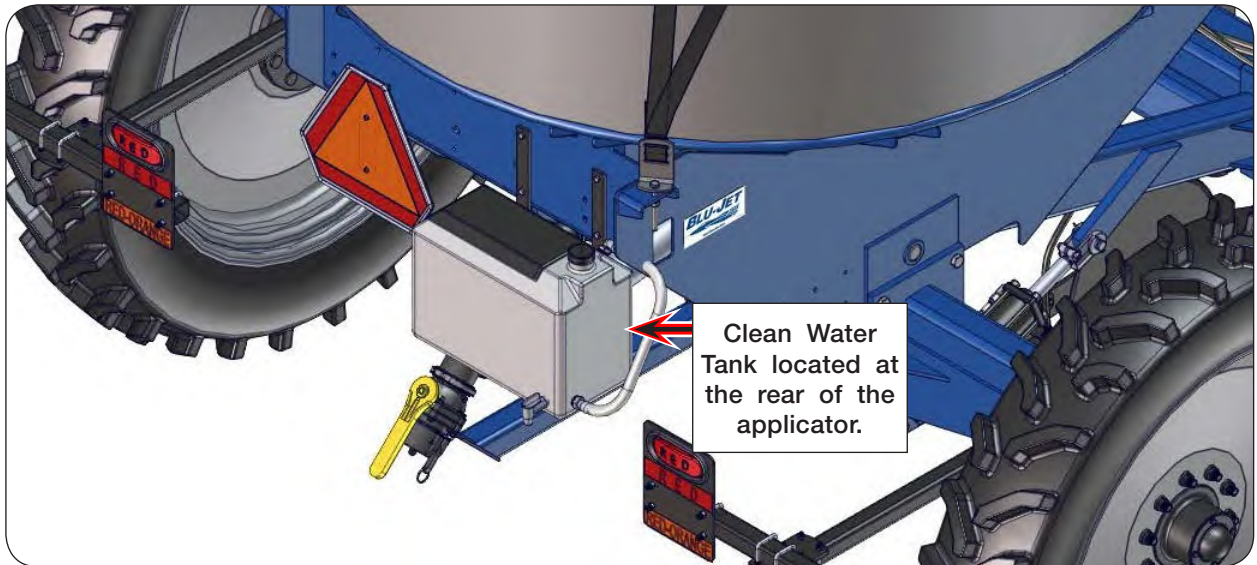



- A clean water tank is provided as standard equipment. It is equipped with a spigot for general washing and a hose for emergency eye washing.
- Always keep clean water in tank. Water in clean water tank is not suitable for human consumption.
- For emergency eyewash, pull hose off of the top fitting and flush affected area.



Preparing for Emergencies

- Keep a first aid kit and properly rated fire extinguisher nearby.  
- Keep emergency numbers for fire, rescue, and poison control personnel near the phone. 
- A clean water tank is provided as standard equipment. It is equipped with a spigot for general washing and a hose for emergency eye washing.
- Always keep clean water in tank. Water in clean water tank is not suitable for human consumption.
- For emergency eyewash, pull hose off of top fitting and flush affected area.

Wearing Protective Equipment

- Wear clothing and personal protective equipment appropriate for the job.  
- Wear steel-toed shoes when operating. 
- Wear hearing protection when exposed to loud noises. 
- Do not wear additional hearing impairing devices such as radio headphones, etc.



SECTION II
Set Up

General Set Up Information.....2-2
Unloading Applicator from Shipping Trailer.....2-3
 Tongue Assembly to Main Frame Assembly.....2-3
Main Frame Transportation Wheels2-6
Pump Drive.....2-7
Coulter Assembly2-8
Gauge Wheel Assembly2-8
Transport Lighting Assembly.....2-8
Pump Set Up - For Units with Centrifugal Pump.....2-9
 Setting the Pump Pressure (non-PWM Pump).....2-9
Rate Orifice Installation2-10
Overhead Layouts2-11

General Setup Information

For your safety, and the safety of others, use proper tools and equipment and always use safe working procedures. Refer to these instructions before starting any work on your machine.

For ease of assembly, install all hardware loosely until assembly is complete and then tighten according to “Torque Chart” unless otherwise specified.

WARNING

- **READ AND UNDERSTAND SAFETY RULES BEFORE OPERATING OR SERVICING THIS MACHINE. REVIEW SAFETY SECTION IN THIS MANUAL, IF NECESSARY.**
- **TIPPING OR MOVEMENT OF THE MACHINE CAN CAUSE SERIOUS INJURY OR DEATH. BE SURE THE MACHINE IS SECURELY BLOCKED.**
- **MOVING PARTS CAN CRUSH AND CUT. KEEP AWAY FROM MOVING PARTS.**
- **KEEP HANDS CLEAR OF PINCH POINT AREAS.**
- **TIPPING OR MOVEMENT OF THE APPLICATOR CAN CAUSE SERIOUS INJURY OR DEATH. APPLICATOR MUST BE HITCHED TO THE TRACTOR BEFORE OPERATING.**
- **FALLING OBJECTS CAN CAUSE SERIOUS INJURY OR DEATH. DO NOT WORK UNDER THE MACHINE AT ANY TIME WHILE BEING HOISTED. THESE ASSEMBLY INSTRUCTIONS WILL REQUIRE SAFE LIFTING DEVICES UP TO 8,000 LBS. SPECIFIC LOAD RATING FOR INDIVIDUAL LOADS WILL BE GIVEN AT THE APPROPRIATE TIME IN THE INSTRUCTIONS.**
- **EYE PROTECTION AND OTHER APPROPRIATE PERSONAL PROTECTIVE EQUIPMENT MUST BE WORN WHILE SERVICING THE IMPLEMENT.**

IMPORTANT

- *The procedures for assembling this unit were intended for two or more people.*

Unloading Applicator from Shipping Trailer

Tongue Assembly to Main Frame Assembly

1. Remove the twelve 3/4"-10UNC x 2" capscrows, grade 8 (91299-145), twelve 3/4"-10UNC lock nuts (97025), four 3/4"-10UNC x 5 11/16" U-bolts, grade 5 (JBP3352), eight 3/4" USS flat washers (9405-106), and eight 3/4"-10UNC hex nuts (9394-016) from the tongue assembly. (FIG. 2-1)

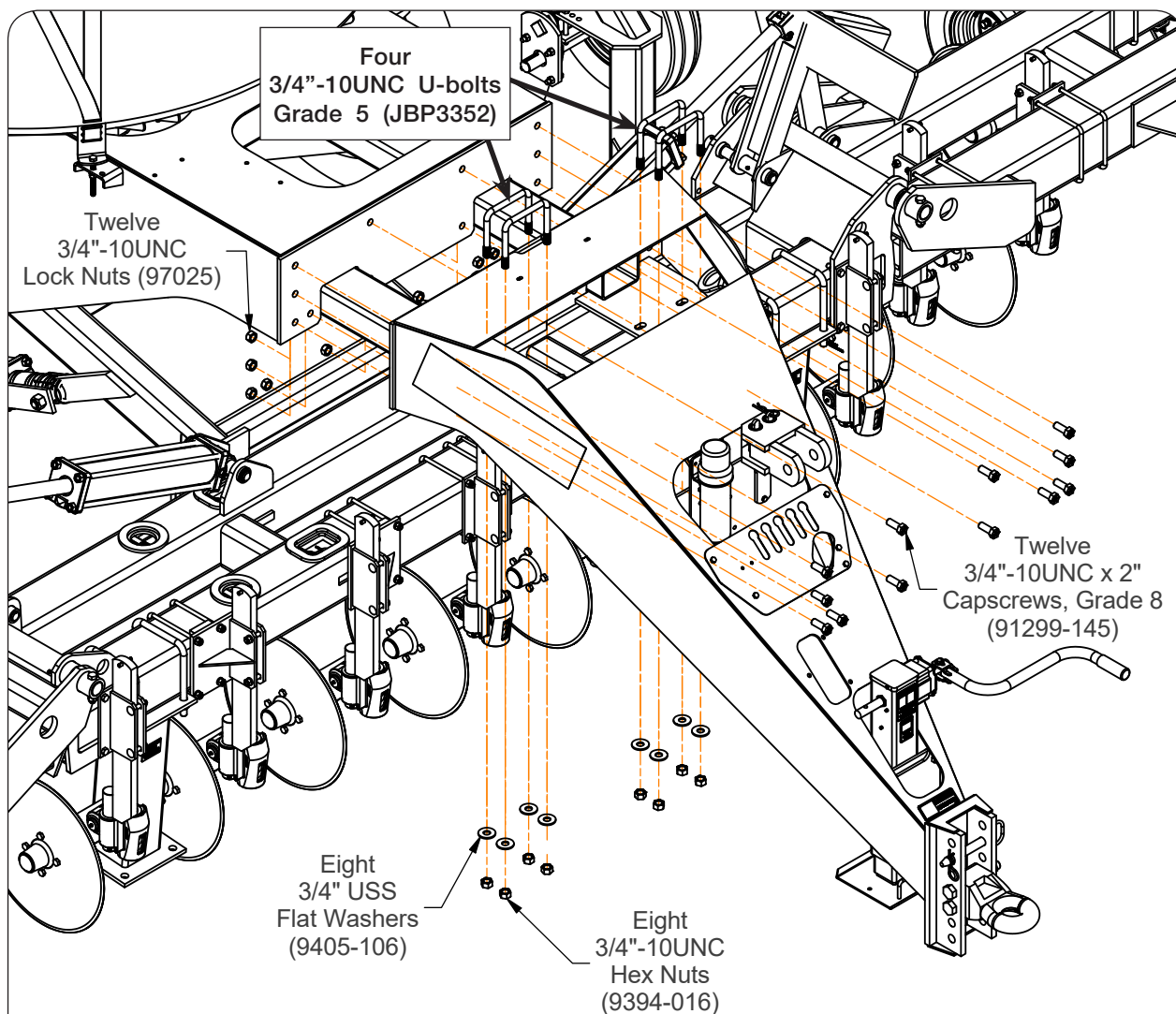

FIG. 2-1

2. Using a safe lifting device rated at a minimum of 1,000 lbs., support the tongue assembly. Attach the tongue assembly to main frame with twelve 3/4"-10UNC x 2" capscrows, grade 8 (91299-145), twelve 3/4"-10UNC lock nuts (97025), four 3/4"-10UNC x 5 11/16" U-bolts, grade 5 (JBP3352), eight 3/4" USS flat washers (9405-106), and eight 3/4"-10UNC hex nuts (9394-016) (FIG. 2-1). Torque hardware according to "Torque Chart" in MAINTENANCE section.

Unloading Applicator from Shipping Trailer (continued)

3. Route hydraulic hoses through the tongue assembly.
4. Attach the bulkhead plate to the tongue assembly with three 3/8"-16UNC x 1" capscrews (9390-055), 3/8" lock washers (9404-021), and 3/8"-16UNC hex nuts (9394-006). (FIG. 2-2)

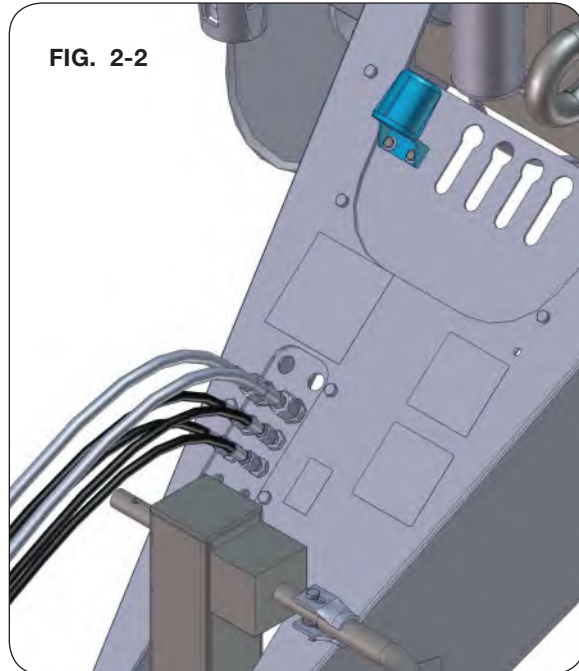

FIG. 2-2

5. Use the chain (96589), 5/16"-18UNC x 1 1/4" capscrews (9390-031), 5/16" flat washers (9405-070), and 5/16"-18UNC hex nuts (9394-004) to support the hydraulic hoses to the underside of the tongue assembly. (FIG. 2-3)

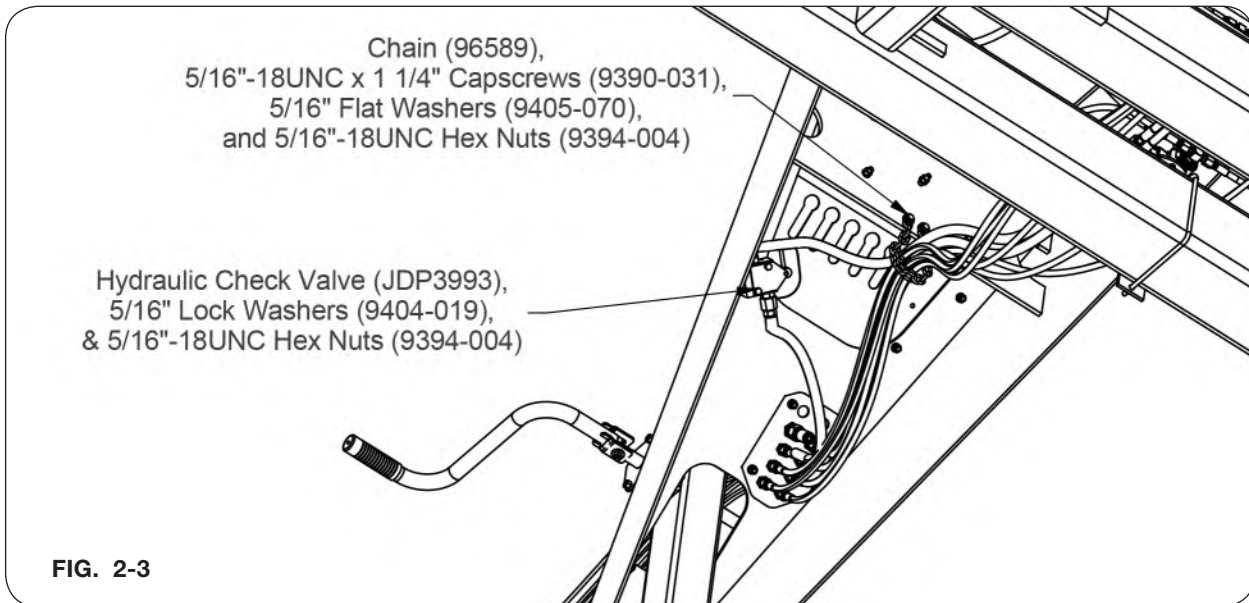

FIG. 2-3

6. Attach the hydraulic check valve (JDP3993) to the underside of the utility plate with two 5/16" lock washers (9404-019) and 5/16"-18UNC hex nuts (9394-004). (FIG. 2-3)
7. Torque hardware according to "Torque Chart" in MAINTENANCE section.

Unloading Applicator from Shipping Trailer (continued)

8. Refer to “Hitching to the Tractor” in OPERATION section. Attach Applicator to the tractor.
9. Check all hoses and cylinders for signs of leakage. Hoses should not be kinked, twisted or rubbing against sharp edges. Re-route or repair hoses as necessary. Refer to SAFETY section for additional information on safe repair and inspection of hydraulic components.
10. Raise the toolbar and remove the yellow transport brackets and hardware from the main frame cylinder transport wheels (FIG. 2-4). Insert cylinder 1” Dia. x 4” clevis pins (JBP3497) and 3/16” Dia. x 1 3/4” cotter pins (9391-045).



11. Raise applicator into transport position.

12. Remove the toolbar shipping stands and hardware. (FIG. 2-5)



13. With the tractor connected and the applicator raised, pull the applicator from the shipping trailer.
14. Park the unit on a firm, level surface. Unfold the wings and lower the machine onto the transport stops. Set the towing vehicle’s parking brake, shut-off the engine and remove the ignition key.

Main Frame Transportation Wheels

1. Unit should be parked on a firm, level surface, wings unfolded and unit lowered onto the transport stops. Make sure the towing vehicle's parking brake is on, the engine shut-off and the ignition key removed.
2. Using a safe lifting device and support stands rated at a minimum of 8,000 lbs., raise and support one side of the main frame assembly.
3. Using a safe lifting device rated at a minimum of 400 lbs., remove and save the main frame transportation wheels (111189Y) and 3/4"-16UNF wheel nuts (92458) from the main frame. (FIG. 2-6)

NOTE: Return shipping stands and transportation wheels.

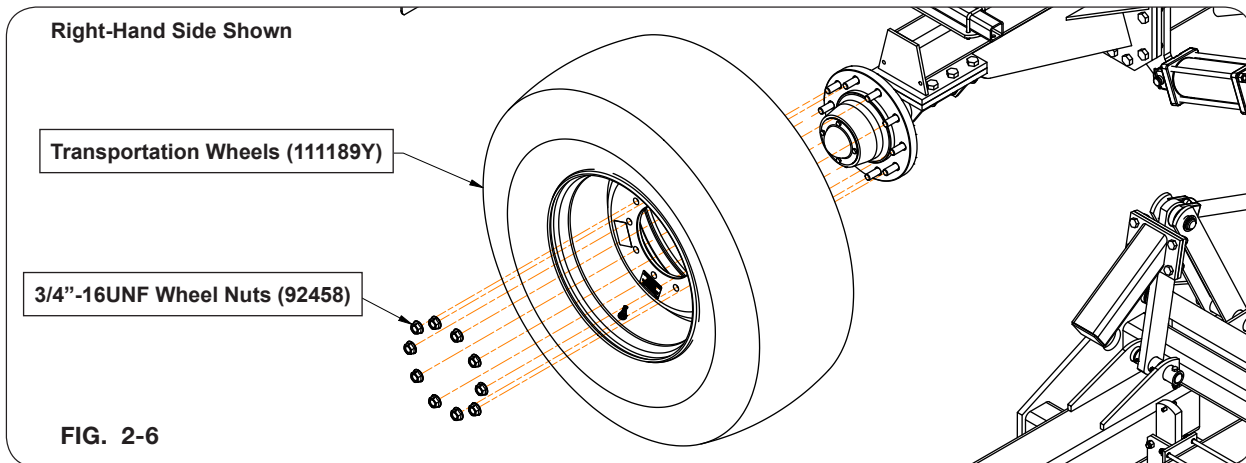

4. Using a safe lifting device rated at a minimum of 750 lbs., attach the wheel and tire assembly (111276SM) with the valve stem facing out. Secure using the 3/4"-16UNF wheel nuts (92458) previously removed (FIG. 2-7). Torque hardware according to "Wheel Torque Specification" in MAINTENANCE section.

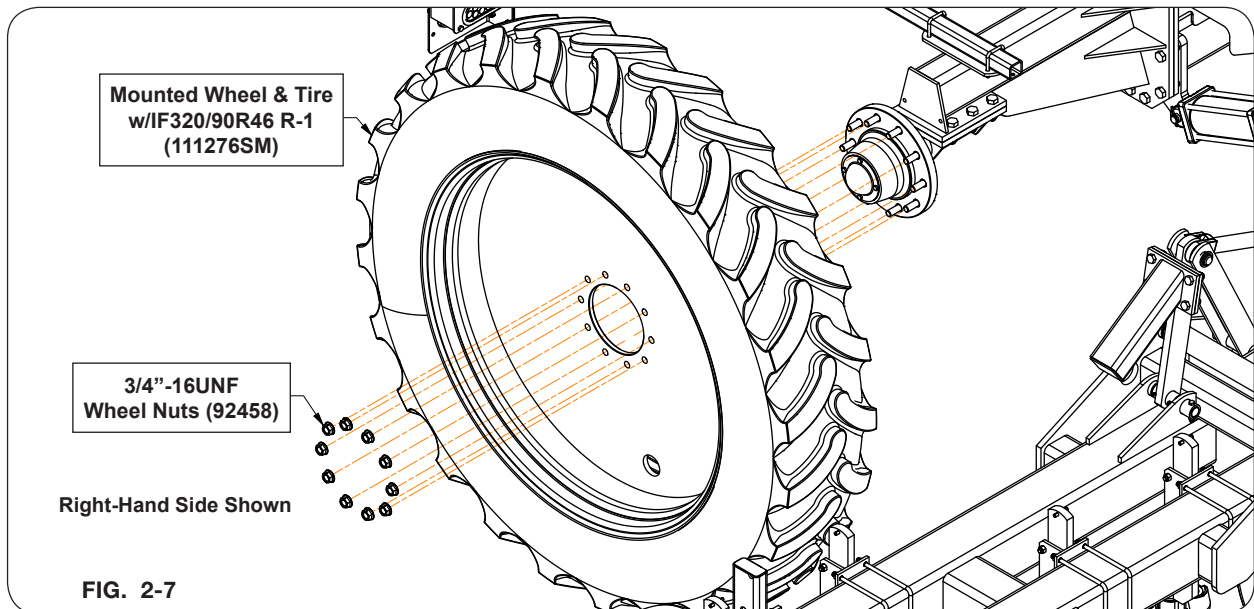

5. Repeat steps 2 through 4 on the opposite side.

Pump Drive

1. Lower the toolbar to working position.
2. Using a safe lifting device rated at a minimum of 150 lbs., support the pump drive wheel and axle.
3. Remove the 1/2"-13UNC x 4 1/2" capscrews (9390-112) and 1/2"-13UNC lock nuts (9800) from the pump drive axle mounting plate.
4. Reposition the pump drive wheel so it contacts the left-hand main frame wheel and reinstall the previously removed 1/2"-13UNC x 4 1/2" capscrews (9390-112) and 1/2"-13UNC lock nuts (9800) from the pump drive axle mounting plate.
5. Torque hardware according to "Torque Chart" in MAINTENANCE section.

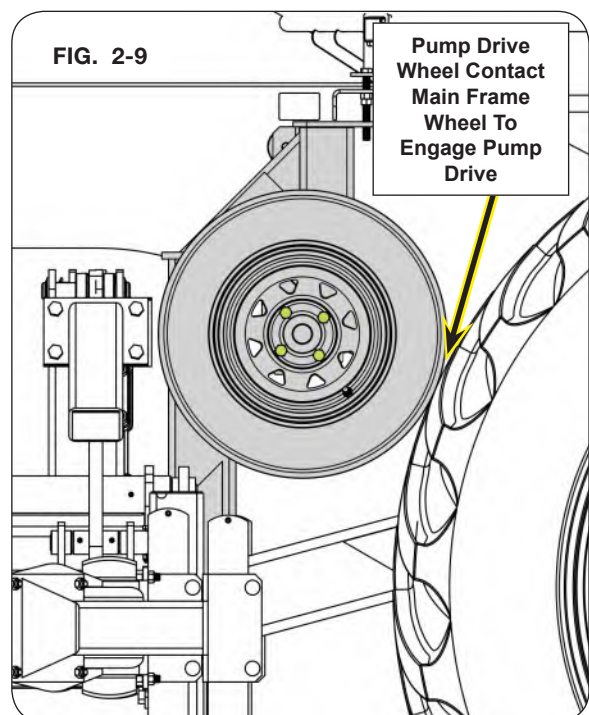
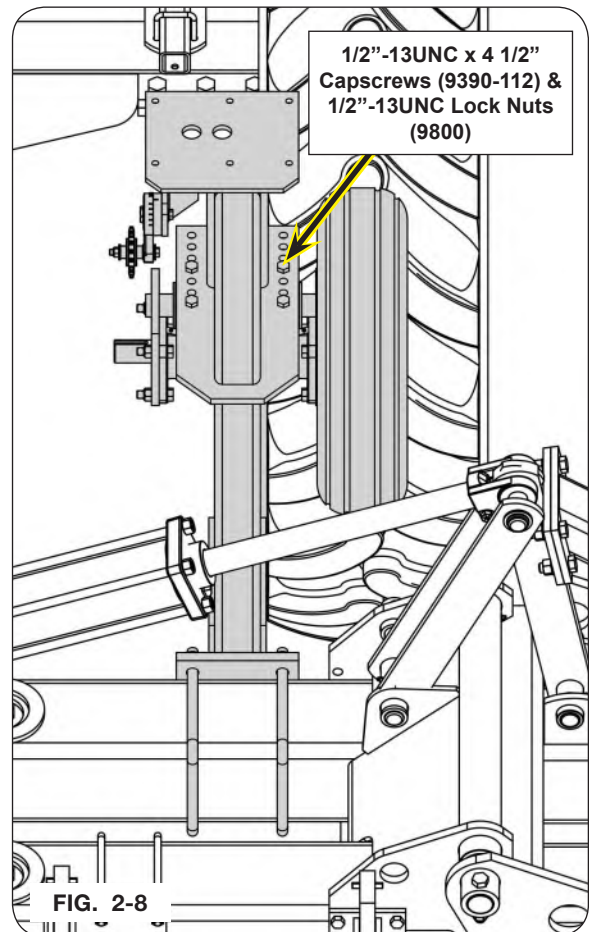

Coulter Assembly

1. Use “Overhead Layouts” in this section to properly position coulter assemblies. Torque hardware according to “Torque Chart” in MAINTENANCE section.

Gauge Wheel Assembly

1. Use “Overhead Layouts” in this section to properly position gauge wheels. Torque hardware according to “Torque Chart” in MAINTENANCE section.

Transport Lighting Assembly

Compliance with all lighting and marking laws is the responsibility of the operator at the time of travel.

See federal regulation 49 CFR 562; available at www.govinfo.gov for US federal law requirements.

See your Unverferth dealer for additional brackets, reflectors, or lights to meet your requirements.

NOTE: Consult “Overhead Layouts” for light kit placement.

SMV Emblem

Before the applicator is used the reflective surface of the SMV must face rearward. This may require removal of film protecting the reflective surface or removing and reinstallation of the SMV. When reinstalling the SMV make sure that it is mounted with the wide part of the SMV at the bottom.

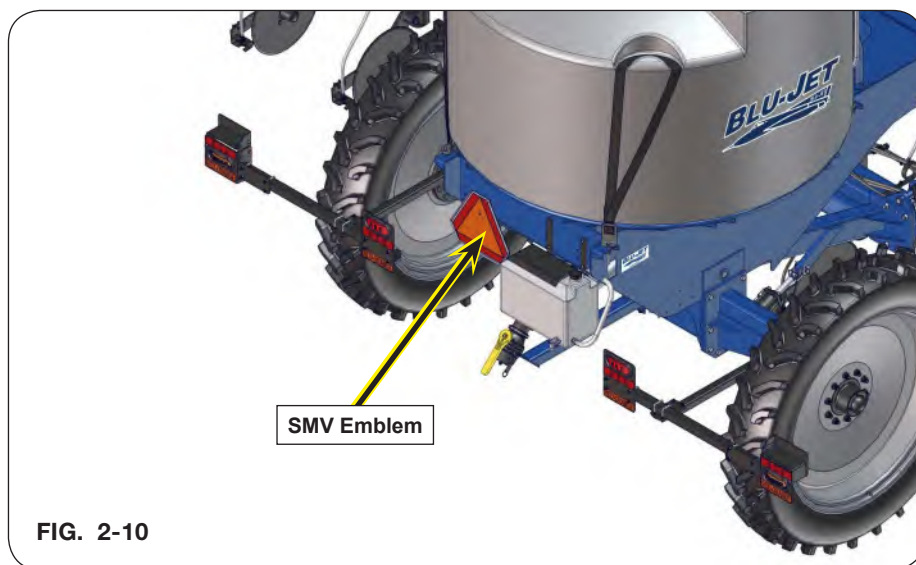

FIG. 2-10

Pump Set Up — For Units With Centrifugal Pump

For set up of a non-PWM pump, refer to your rate controller manual for details. For specific details related to your product pump, please refer to your pump manual.

IMPORTANT

- Do not run pump for extended periods with outlet flow fully blocked. Overheating and pump damage can result.
- Liquid must be in the Solution Tank. Refer to Filling Applicator in the OPERATION Section.
- Toolbar should be unfolded when setting the pump pressure. Refer to toolbar operation in the OPERATION Section.
- The Pump Inlet valve should be open.
- Do not run pump without solution. Running a dry pump will shorten its life.



FIG. 2-16

Setting the Pump Pressure (non-PWM Pump)

1. Adjust circuit flow to minimum setting prior to operating for the first time.
2. Turn off section valves and agitation valve if equipped.
3. Engage hydraulic lever to RETRACT position.
4. Increase the flow in the tractor until the filter inlet or pump pressure is 100 psi.
5. Increase the agitation so pump pressure drops by 5 psi. The gauge should now read 95 psi.

Rate Orifice Installation

1. Consult “Row Spacing Rate Chart” in MAINTENANCE section for orifice size.
2. Remove nozzle nut and insert orifice.
3. Travel a few feet and check blade depth. Adjust gauge wheels or coulter to achieve the 4” depth.
4. Check all nozzles for stream of liquid behind blade.
5. Make adjustment to nozzle assembly so stream is in line with the blade trench.

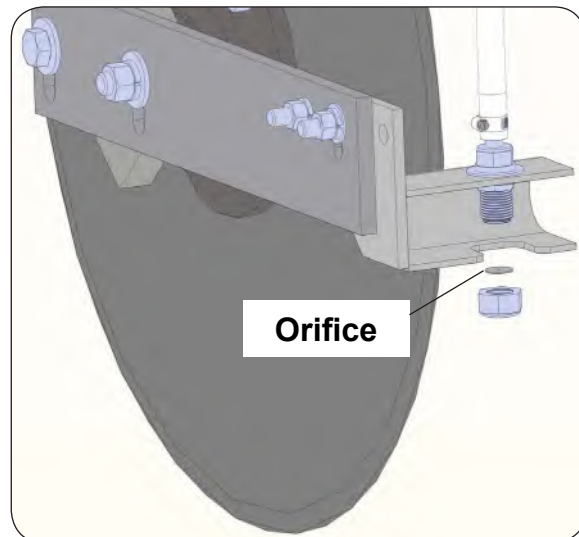

Overhead Layout — 15 Row 30" Spacing (15 Row 30") Gull Wing

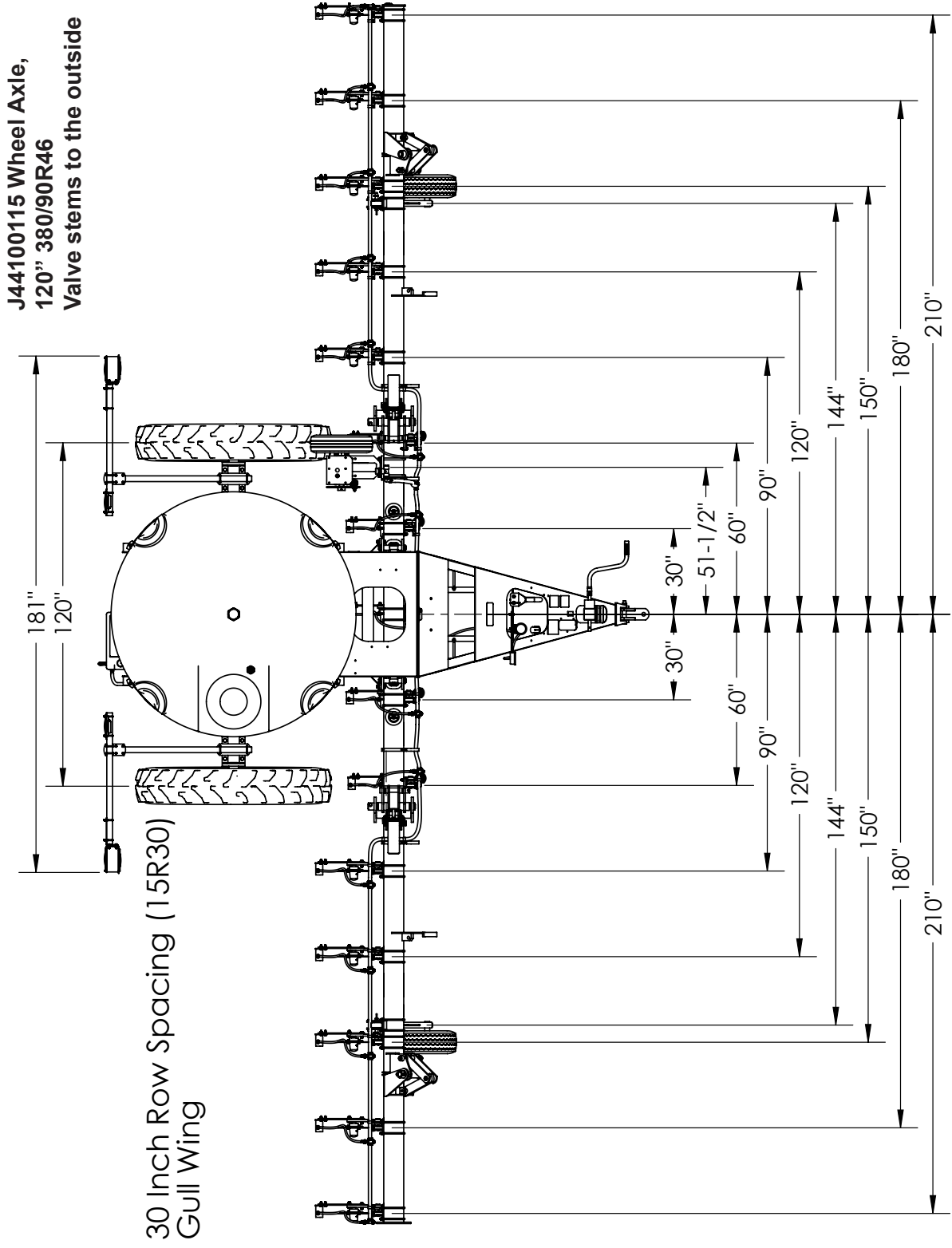

Overhead Layout — 17 Row 30" Row Spacing (17 Row 30") Gull Wing

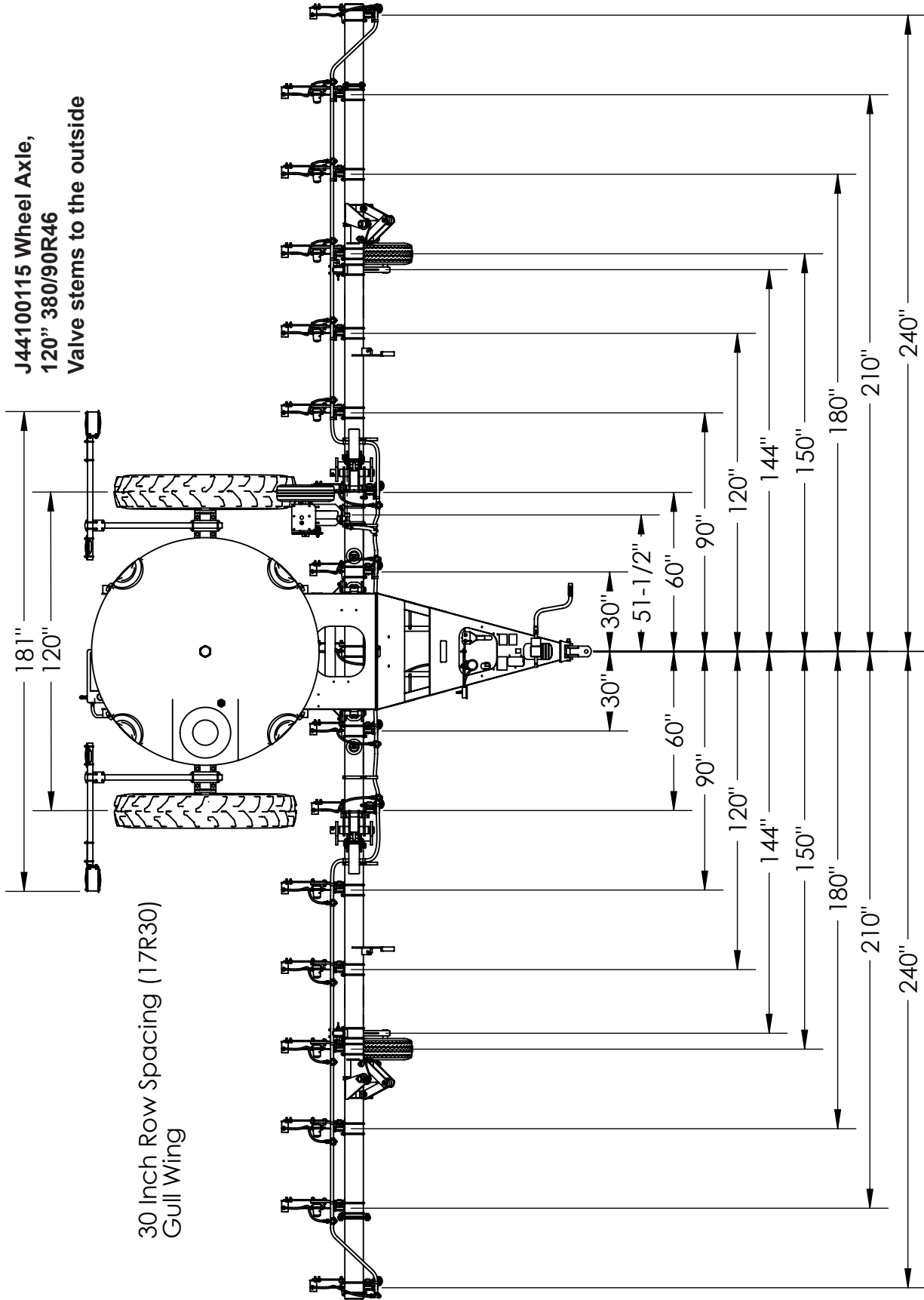

Overhead Layout — 23 Row 30" Row Spacing (23R30) Gull Wing

NOTE:
Set light brackets at 160" when optional folding coulters are installed.

AT4615
LIQUID APPLICATOR
23 ROW 30"

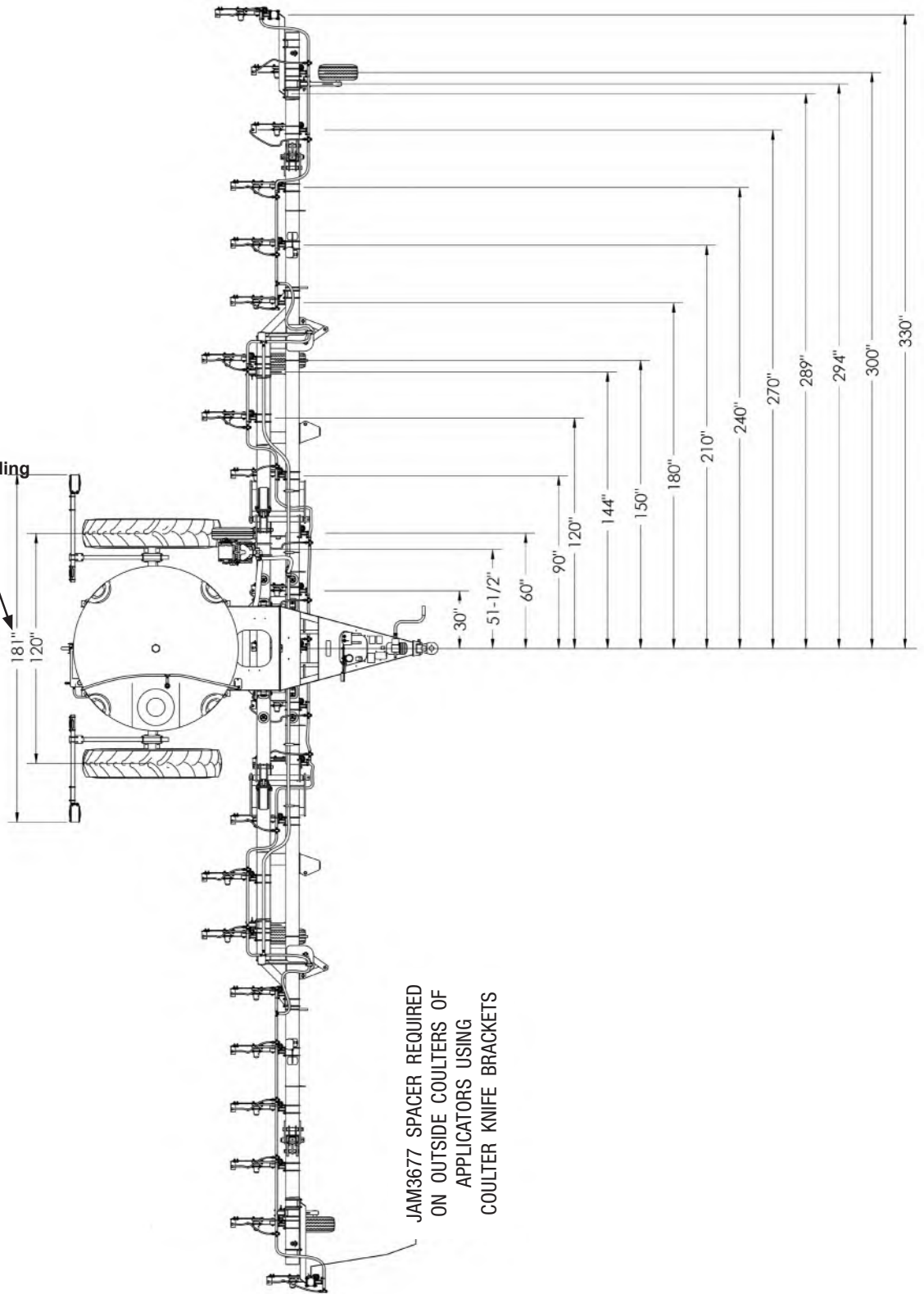

JAM3677 SPACER REQUIRED
ON OUTSIDE COULTERS OF
APPLICATORS USING
COULTER KNIFE BRACKETS

Overhead Layout — 25 Row 20" Row Spacing (25R20) Gull Wing

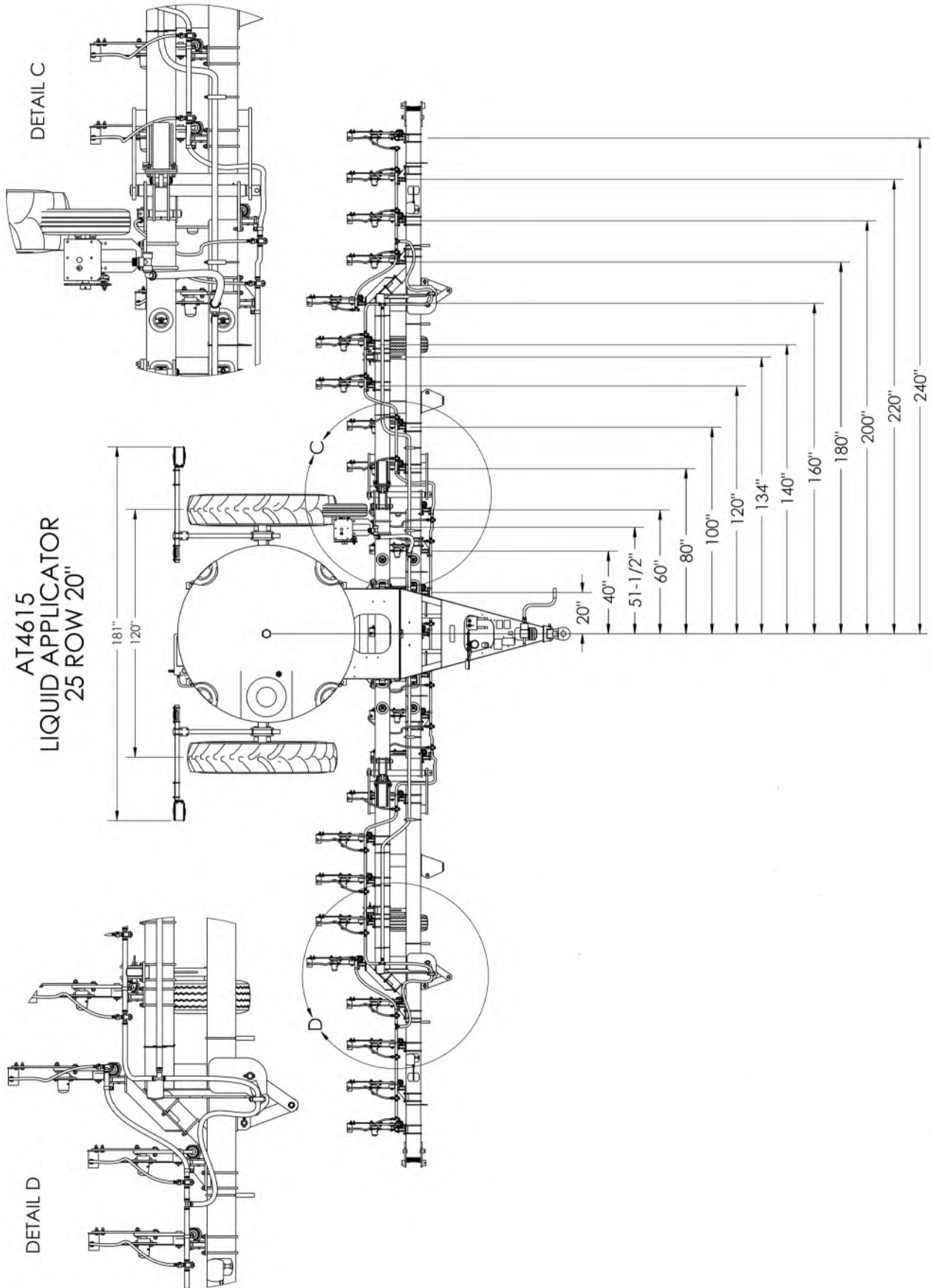

Overhead Layout — 25 Row 30" Row Spacing (25R30) Gull Wing

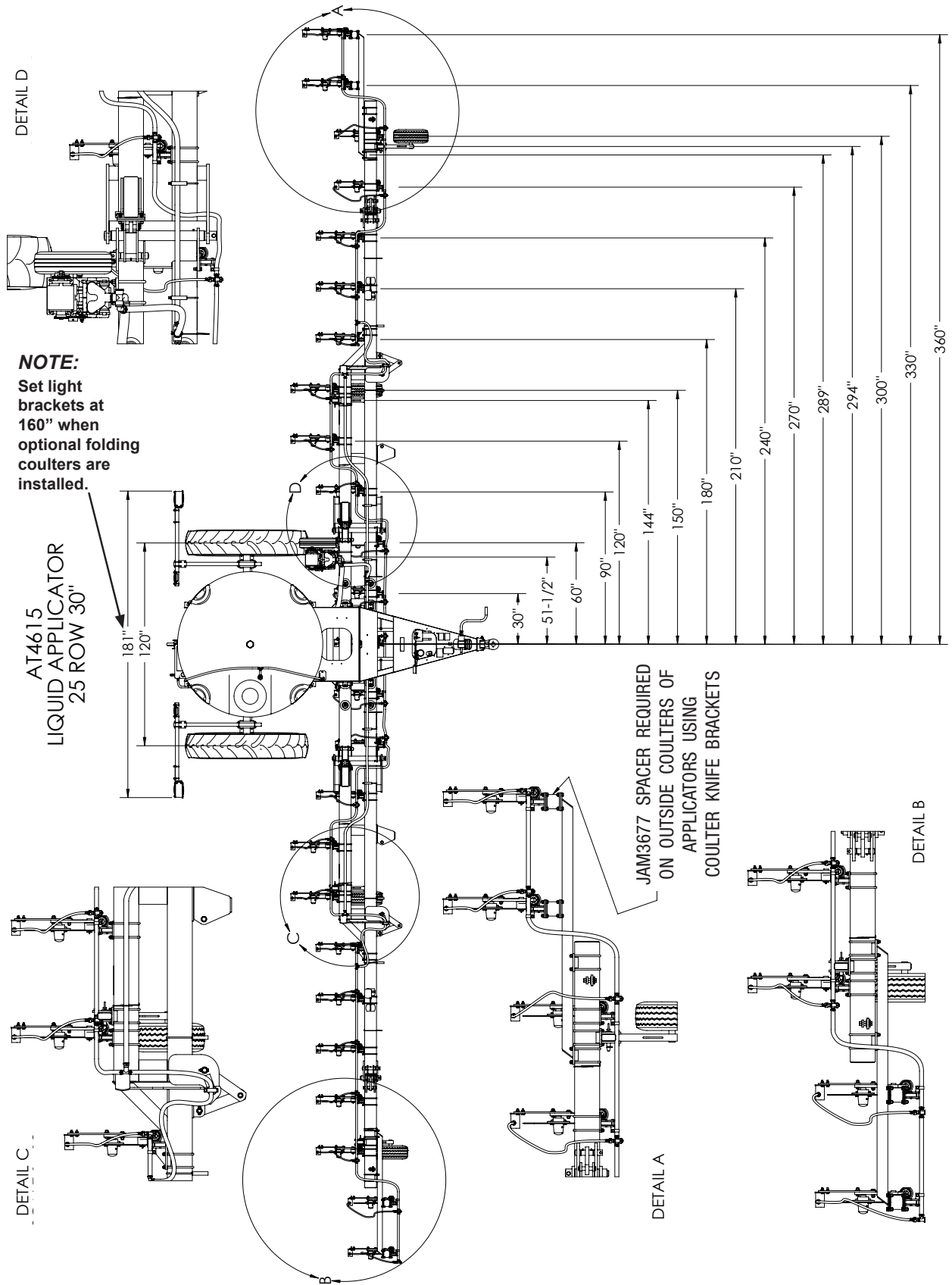

Overhead Layout — 27 Row 18" Row Spacing (27R18) Gull Wing

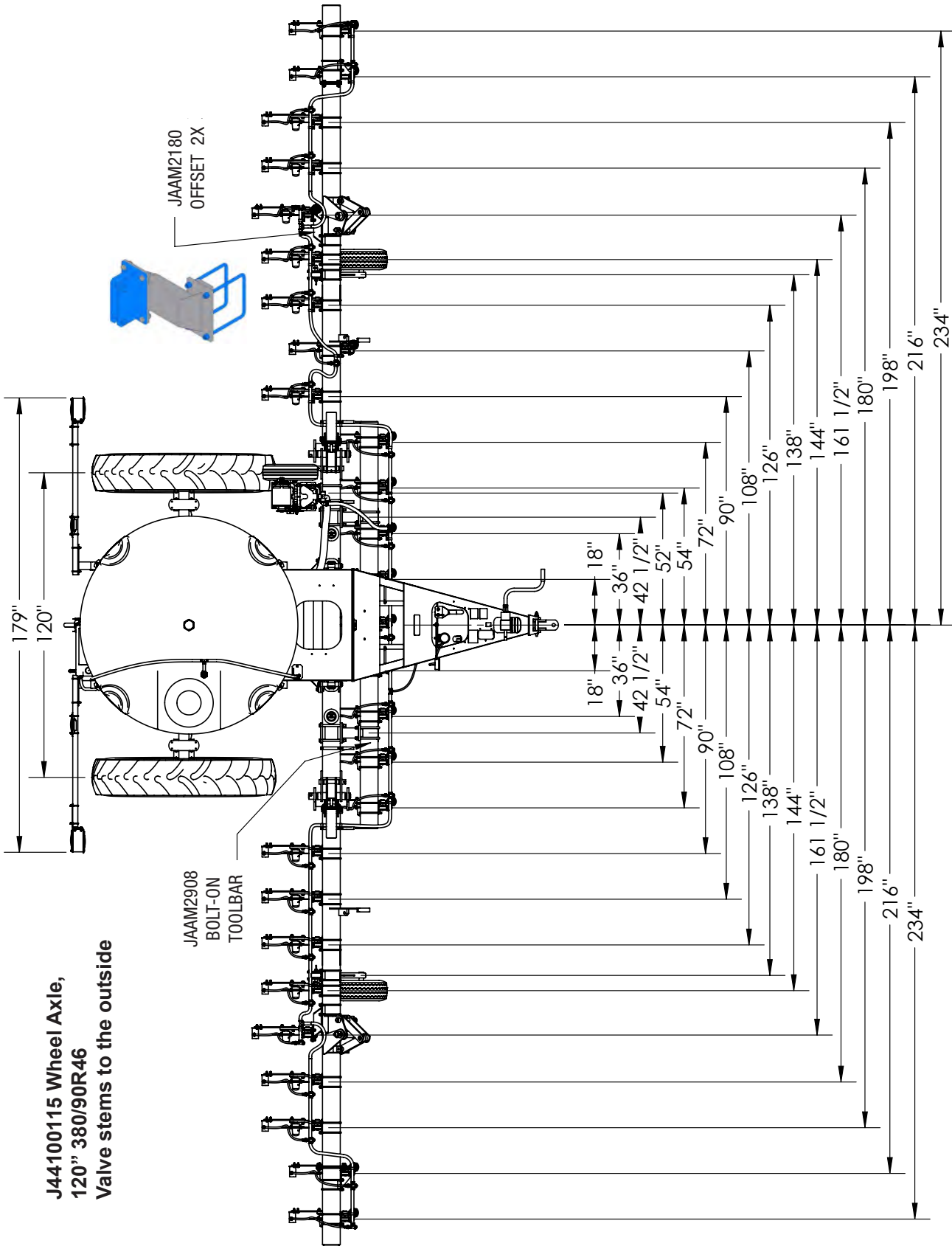

Overhead Layout — 33 Row 15" Row Spacing (33R15) (Small Grain)

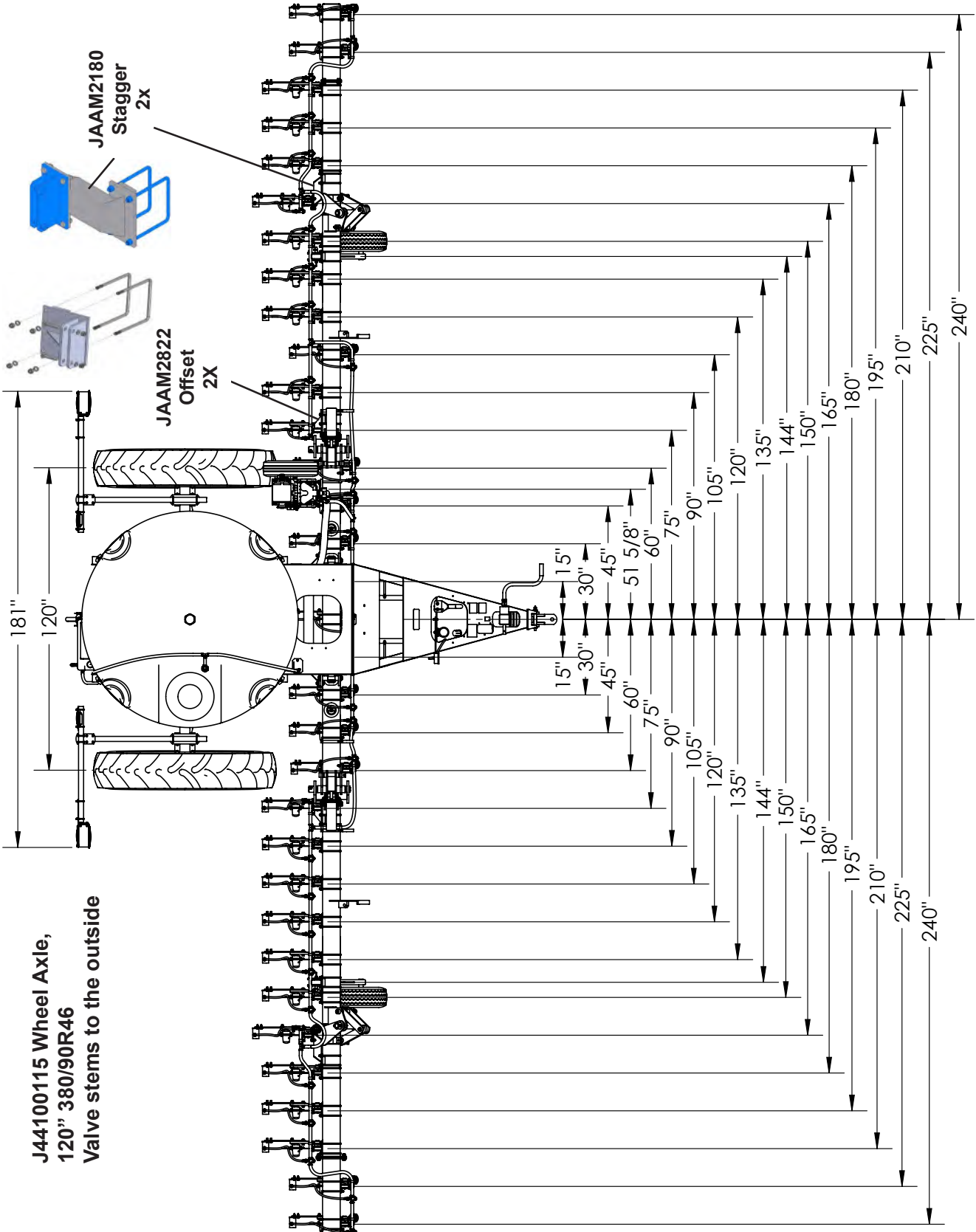

Overhead Layout — 35 Row 20" Row Spacing (35R20) Gull Wing

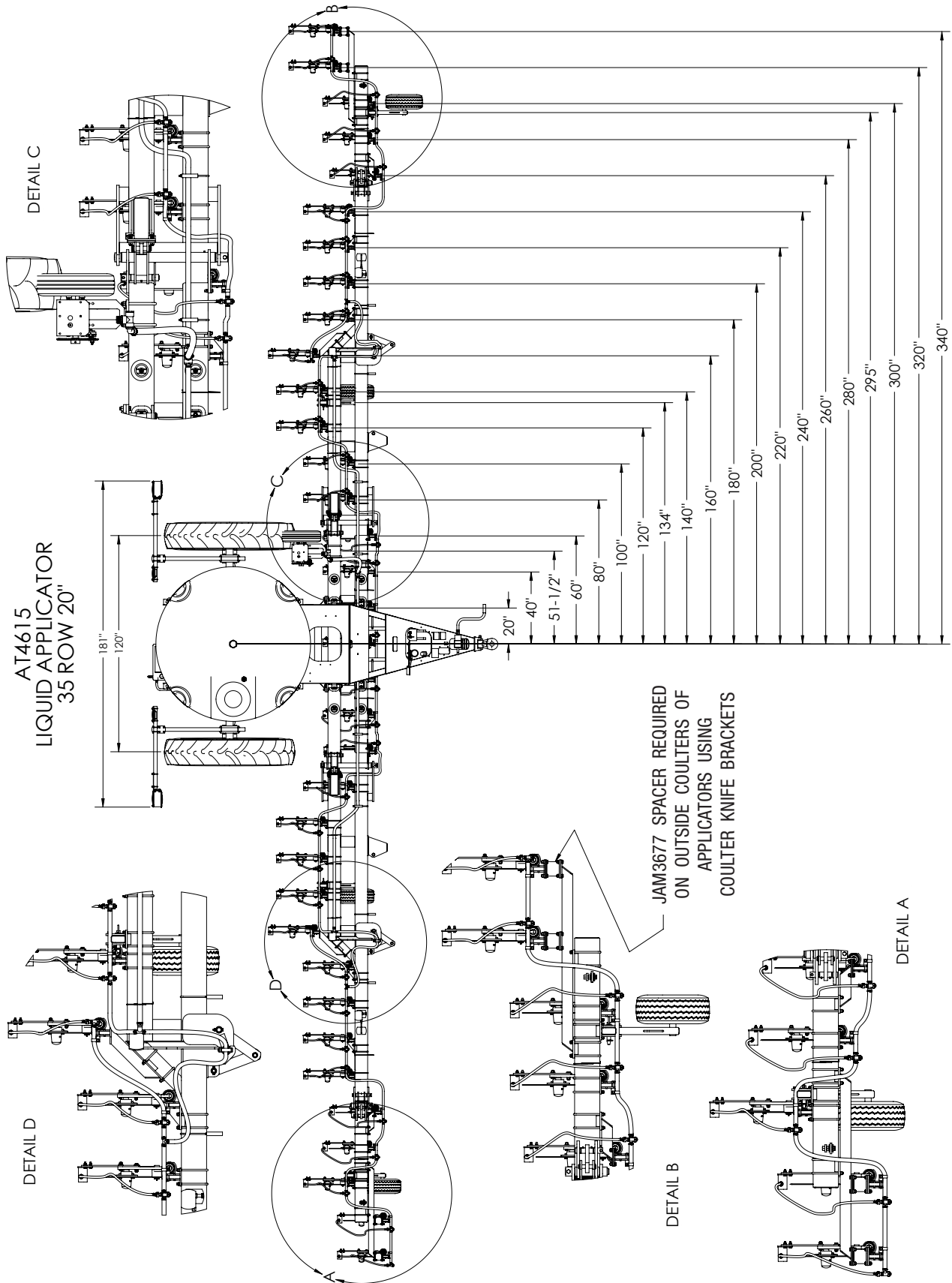

SECTION III

Operation

Preparing Tractor	3-2
Preparing Applicator.....	3-2
Hardware.....	3-2
Pivot Pins	3-2
Hitch	3-2
Hydraulic System.....	3-2
Tires/Wheels.....	3-3
Lubrication	3-3
Leveling Machine.....	3-3
Hitching to the Tractor.....	3-4
Drawbar Hitching.....	3-4
Transport Chain	3-5
Hydraulic Connections.....	3-6
Applicator Solution Pump Hydraulics - For Units with Centrifugal Pump Option	3-7
Electrical Connection	3-7
Jack Usage.....	3-8
Parked Position.....	3-8
Transport Position.....	3-8
Transporting	3-9
Drawbar Connection	3-9
Bottom Fill Valve Operation.....	3-10
Clean Water Tank	3-10
Unfolding Toolbar	3-11
Adjusting Toolbar Flex	3-13
Depth Adjustment	3-14
Folding Toolbar.....	3-15

FOR CONTROLLER OR PUMP INFORMATION, PLEASE REFER TO YOUR
CONTROLLER AND PUMP MANUAL.

FOR GROUND DRIVEN PUMP INFORMATION, PLEASE REFER TO PUMP MANUAL.

Preparing Tractor

Before operating applicator, read the tractor operator's manual and gain an understanding of its safe methods of operation.

Check the tractor brakes and transport lights. Make sure they are in proper working order.

Check the tractor hydraulic oil reservoir and add oil if needed.

Verify that the tractor is adequately ballasted for drawbar operation at the anticipated draft and vertical tongue load. Vertical tongue load of a loaded applicator is approximately 8,500 lbs. unfolded (4800 lbs. with toolbars folded to transport position). Ensure that the tractor's drawbar has sufficient strength to support this load.

If possible, adjust the tractor drawbar vertically so the top side of the drawbar is at least 18 inches from the ground. Alternately, the applicator hitch may be adjusted vertically by choosing other mounting holes provided.

Raise and secure all tractor 3-point hitch linkage to prevent interference with the implement tongue and hydraulic hoses during turning.

Preparing Applicator

Perform the service checks as outlined. Repair or replace any damaged or worn parts before operating.

Hardware

Check for loose bolts and nuts, and tighten as needed. Check again after the first half-day of operation.

Pivot Pins

Check that all pins are in place and in good condition. Replace any worn, damaged or missing pins.

Hitch

Check hitch and hitch retention hardware for damage and wear.

Hydraulic System

Check all hoses and cylinders for signs of leakage. Hoses should not be kinked, twisted or rubbing against sharp edges. Re-route or repair hoses as necessary. Refer to SAFETY section for additional information.

Preparing Applicator (continued)

Tires/Wheels

Check tire pressures and maintain at recommended values listed in the MAINTENANCE section.

CAUTION

- IMPROPERLY TORQUED WHEEL NUTS/BOLTS CAN CAUSE A LOSS OF IMPLEMENT CONTROL AND MACHINE DAMAGE. WHEEL NUTS/BOLTS MUST BE CHECKED REGULARLY. SEE TORQUE PAGE IN THE “MAINTENANCE” SECTION FOR PROPER WHEEL NUT/BOLT SPECIFICATIONS. WARRANTY DOES NOT COVER FAILURES CAUSED BY IMPROPERLY TORQUED WHEEL NUTS/BOLTS.

IMPORTANT

- *Installing wheels without the proper inset could result in hub or spindle failure. This will cause substantial damage to the applicator.*

For questions regarding new tire warranty, please contact your local original equipment tire dealer. Used tires carry no warranty. Tire manufacturers' phone numbers and web sites are listed in the “MAINTENANCE” section for your convenience.

Lubrication

Lubricate the applicator as outlined in the MAINTENANCE section.

Leveling Machine

1. Before leveling the machine the tire pressure should be checked. Inflate center section lugged tractor tires to 64 PSI maximum.
2. Before beginning operation of this machine the main frame must be on level surface. Adjust the hitch up or down in the tongue connector and connect to tractor (FIG. 3-1).

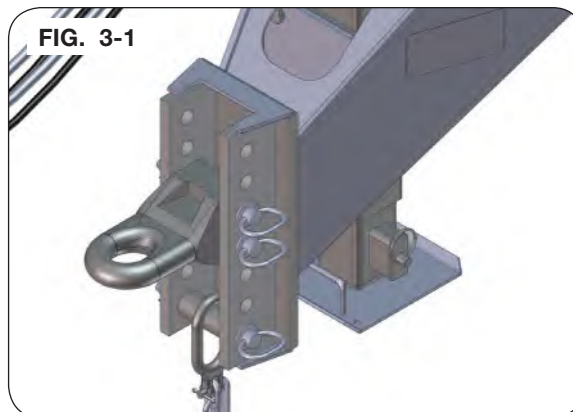

Hitching to the Tractor

Drawbar Hitching

⚠ WARNING

- **CRUSHING CAN CAUSE SERIOUS INJURY OR DEATH. DO NOT STAND BETWEEN TOWING VEHICLE AND IMPLEMENT WHEN HITCHING. ALWAYS ENGAGE PARKING BRAKE AND STOP ENGINE BEFORE INSERTING HITCH PINS OR SECURING LATCHES.**

Connect the hitch to the tractor drawbar. Do not attempt to hitch to any other location on the tractor. (FIG. 3-2)

NOTE: Only use the centered position on the tractor drawbar.

The implement is equipped with a ball swivel hitch (JAP3232) and requires a 2" diameter drawbar pin. Clevis hitch (JAM2144) requires a 1 1/4" diameter drawbar pin.

The applicator must be relatively level in order for the tank volume indicator to read accurately.

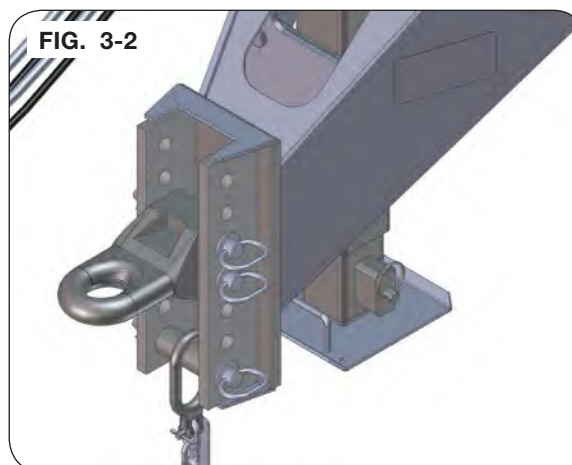

IMPORTANT

- *The use of a smaller-diameter hitch pin will result in additional clearance between the implement hitch and pin. This additional clearance may cause accelerated pin and hitch wear, along with more pronounced jolting from the implement during operation.*
- *Verify and/or adjust the applicator hitch height before coupling to the tractor. The applicator hitch is adjusted by unbolting the hitch and reinstalling in a different set of holes provided.*
- *After inserting drawbar pin, secure with a locking device to help prevent uncoupling during use.*

Hitching to the Tractor (continued)

Transport Chain

Always use a transport chain when connecting the implement directly to a tractor. Make sure the intermediate chain support is in use. DO NOT use the intermediate chain support as the chain attaching point. FIG. 3-4 shows how the transport chain must be installed between the tractor and implement.

Transport chain should have a minimum rating equal to the gross weight of the implement and all attachments. Use only ASABE approved chain. Allow no more slack in the chain than necessary to permit turning.

Transport chain connection shown for illustration purposes only. Refer to tractor manufacturer for proper attachment.

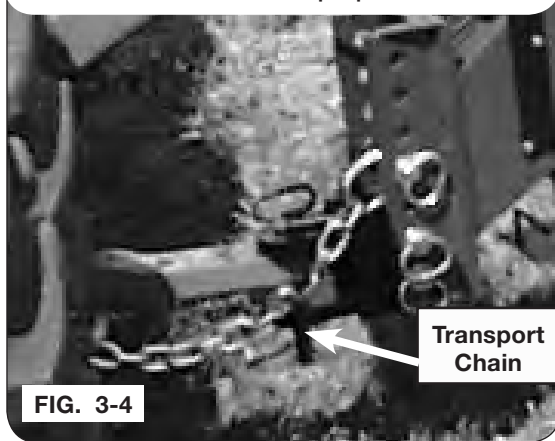

⚠ CAUTION

- REPLACE TRANSPORT CHAIN IF ANY LINK OR END FITTING IS BROKEN, STRETCHED OR DAMAGED. DO NOT WELD TRANSPORT CHAIN.

Hitching to the Tractor (continued)

Hydraulic Connections

WARNING

- RELIEVE THE HYDRAULIC SYSTEM OF ALL PRESSURE BEFORE ADJUSTING OR SERVICING. SEE THE HYDRAULIC POWER UNIT OPERATOR'S MANUAL FOR PROPER PROCEDURES.

- HYDRAULIC SYSTEM MUST BE PURGED OF AIR BEFORE OPERATING TO PREVENT SERIOUS INJURY OR DEATH.

- HIGH-PRESSURE FLUIDS CAN PENETRATE THE SKIN AND CAUSE SERIOUS INJURY OR DEATH. USE CARDBOARD OR WOOD TO DETECT LEAKS IN THE HYDRAULIC SYSTEM. SEEK MEDICAL TREATMENT IMMEDIATELY IF INJURED BY HIGH-PRESSURE FLUIDS.

CAUTION

- TIPPING OR MOVEMENT OF THE APPLICATOR CAN CAUSE SERIOUS INJURY OR DEATH. APPLICATOR MUST BE HITCHED TO THE TRACTOR BEFORE FOLDING OR UNFOLDING WINGS.

NOTE: Primary wings should use float only when in the field. The secondary and third wings should be in the center/closed position if regular coulters are used, but should be in active down pressure (not float) when swivel coulters are used.

1. Clean hydraulic hose couplers, connected to tractor hydraulic circuits.
2. Connect the toolbar hydraulic hoses to the tractor remote couplers. The 3/8" hoses supply oil to the toolbar lift cylinders. The 1/4" hoses supply oil to the wing fold cylinders.

NOTE: Always connect the hoses so the toolbar raises when the tractor remote control lever is moved rearward and lowers when the lever is moved forward.

NOTE: It may be necessary to tie the hydraulic hoses up to keep them away from the hitch area. A tarp strap around the hoses and between the two point arms works well.

Before disconnecting hoses from the tractor, relieve pressure from the lines. See tractor's operators manual for proper procedure to relieve pressure.

WARNING

- NEW HYDRAULIC SYSTEMS OR SYSTEMS THAT HAVE BEEN MAINTAINED MUST BE PURGED OF AIR BEFORE OPERATING OR MOVING MACHINE TO PREVENT SERIOUS INJURY OR DEATH.

NOTE: Refer to MAINTENANCE section for purging process.

Hitching to the Tractor (continued)

Applicator Solution Pump Hydraulics - For Units with Centrifugal Pump Option

IMPORTANT

- *The applicator pump is hydraulically driven, and needs to be configured correctly to match the type of hydraulic system on the tractor (closed center, open center, load-sensing, etc.). Failure to configure the pump correctly may permanently damage the pump through over-speeding and over-pressurizing. Refer to the SET UP SECTION of this manual for guidelines on configuring the applicator pump.*

Connect hoses from the applicator pump to a tractor selective control valve (SCV) circuit (FIG. 3-5). The pump inlet (marked PUMP PRESSURE) should be connected to the RETRACT port and the pump outlet (marked PUMP RETURN) to a low-pressure return port at the tractor (recommended) or to the EXTEND port. If connected to the EXTEND port, it is recommended to shut the pump down in float to preserve pump life.



FIG. 3-5

NOTE: It is recommended to pressurize all hydraulic circuits using the retract outlets on the SCVs. This allows all circuits to be shut-off by engaging the hydraulic float feature of the tractor hydraulic system.

To protect the applicator pump from damage due to excessive speed, adjust circuit flow to minimum setting prior to operating circuit for the first time. When in operation, adjust flow per instructions listed under the “Basic Applicator Settings” heading in this section.

IMPORTANT

- *Never operate applicator pump dry, or with pump inlet selector valve closed. Pump damage may result.*

Electrical Connection

The main harness has a 7-pin (round) plug conforming to SAE standards that connects to tractor. If your tractor does not have the mating socket connector, contact your tractor dealer. (FIG. 3-6)

The wiring schematic for this applicator, as shown in the maintenance section, complies with current ASABE standards. Always verify correct electrical function before using this applicator.

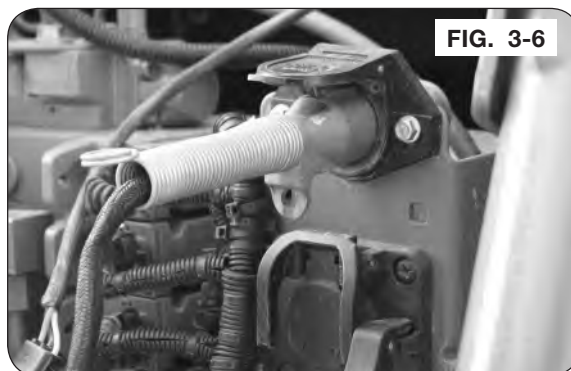

FIG. 3-6

Jack Usage

Parked Position

Lower drop leg to contact the ground. Crank jack leg downward to completely remove the hitch weight from tractor drawbar. (FIG. 3-7)



Transport Position

After tractor connection is established, raise jack leg to highest position to maximize ground clearance. (FIG. 3-8)



Transporting

Drawbar Connection

CAUTION

- **THIS IMPLEMENT IS NOT EQUIPPED WITH BRAKES. ENSURE THAT THE TOWING VEHICLE HAS ADEQUATE WEIGHT AND BRAKING CAPACITY TO TOW THIS IMPLEMENT.**
- **IMMEDIATELY PRIOR TO ROAD TRANSPORT, RUN THE FULL FOLD SEQUENCE FOR PROPER SYSTEM PRESSURES AND TO AVOID INADVERTENT MOVEMENT.**

See towing vehicle manual for towing and braking capacity. Regulate speed to road conditions. Maximum speed of applicator with wheels should never exceed 20 m.p.h.

Secure drawbar pin with a locking device and lock tractor drawbar in centered position.

Install transport lock collars before transporting (FIG. 3-9).

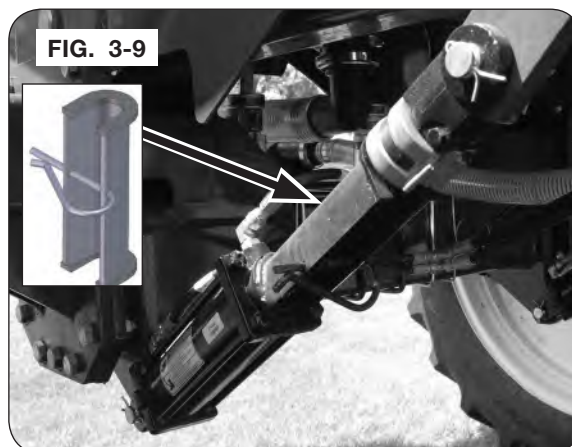

Secure transport chain to tractor before transporting. Use good judgment when transporting equipment on highways. Regulate speed to road conditions and maintain complete control.

It is probable that this implement is taller, wider, and longer than the towing tractor. Become aware of and avoid all obstacles and hazards in the travel path of the equipment, such as power lines, ditches, etc.

Slow down before making sharp turns to avoid tipping. Drive slowly over rough ground and side slopes.

Bottom Fill Valve Operation

1. Screen should be checked and cleaned periodically. See MAINTENANCE section for location and procedure for cleaning filters.

FIG. 3-10



2. To fill tank, remove the cap and attach hose to quick fill coupler. Turn pump inlet valve to closed (Fig. 3-11) and check that tank valve is open (Fig. 3-12). Open fill valve.

3. Fill Applicator to desired level.

NOTE: Sight gauge accuracy depends on the unit being on a level surface and a short delay can be experienced so user should anticipate shutoff for accurate volume.

IMPORTANT

- Do not engage pump until valve is opened.
4. After the tank is filled Close fill valve and open pump inlet valve.
 5. Remove fill hose and reinstall cap when finished.

Closed

Open

FIG. 3-11

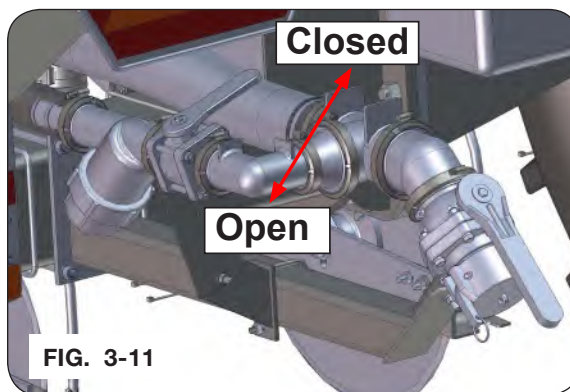

Closed

Open

FIG. 3-12

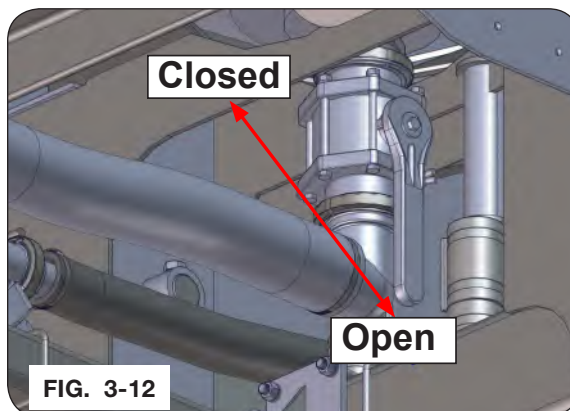

Clean Water Tank

Change water daily to provide fresh clean water to flush exposed skin or eyes. Drain water daily in cold temperatures to prevent freezing and bursting tank.

FIG. 3-13



Unfolding Toolbar

DANGER

- ELECTROCUTION WILL CAUSE SERIOUS INJURY OR DEATH. PERFORM BOOM UNFOLDING AND FOLDING OPERATIONS ONLY IN AREAS WITH ADEQUATE HEIGHT, WIDTH AND LENGTH CLEARANCE. IN PARTICULAR, BE MINDFUL OF LOCATION OF OVERHEAD POWER LINES.

WARNING

- FALLING OR LOWERING EQUIPMENT CAN CAUSE SERIOUS INJURY OR DEATH. KEEP EVERYONE AWAY FROM EQUIPMENT WHEN SUSPENDED, RAISING, OR LOWERING.

1. Unlock the transport lock.

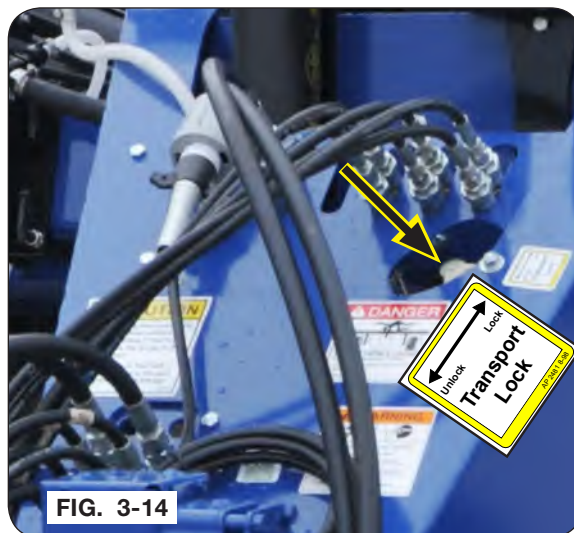

2. Toolbar must be completely raised before unfolding.
3. Unfold the primary wing cylinders first. One side will fold down and then the other.

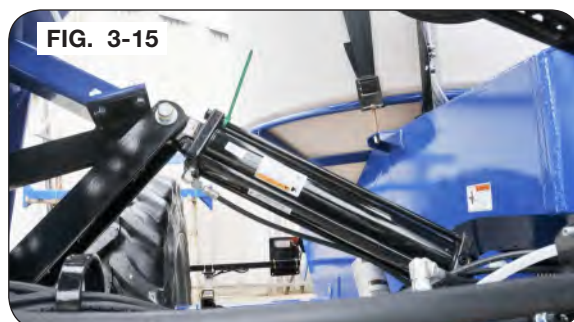

Unfolding Toolbar (continued)

4. Unfold the secondary wing cylinders. Secondary wings swung out.



5. If applicable, unfold the third wing cylinders.



IMPORTANT

- When running in the field the primary wing cylinders must be in float.

Unfolding Toolbar (continued)

- Secondary and third wing cylinders must have pressure applied during field operation when optional folding coulters are used.

NOTE: The secondary and third wings hydraulics should be in the center/closed position if regular coulters are used, but should be in active down pressure (not float) when swivel coulters are used.



Adjusting Toolbar Flex



- ELECTROCUTION WILL CAUSE SERIOUS INJURY OR DEATH. PERFORM BOOM UNFOLDING AND FOLDING OPERATIONS ONLY IN AREAS WITH ADEQUATE HEIGHT, WIDTH AND LENGTH CLEARANCE. IN PARTICULAR, BE MINDFUL OF LOCATION OF OVERHEAD POWER LINES.



- FALLING OR LOWERING EQUIPMENT CAN CAUSE SERIOUS INJURY OR DEATH. KEEP EVERYONE AWAY FROM EQUIPMENT WHEN SUSPENDED, RAISING, OR LOWERING.



- Never unfold the unit without attaching to tractor first. Refer to “Hitching to the Tractor” and “Jack Usage” in this section.

- To adjust 3rd wing toolbar flex, unfold machine as instructed in operation section.
- Raise toolbar and review 3rd wing toolbar flex. Fold Third wing and add or remove spacer plates to achieve desired wing flex. Repeat process until desired flex is obtained. (FIG. 3-19)

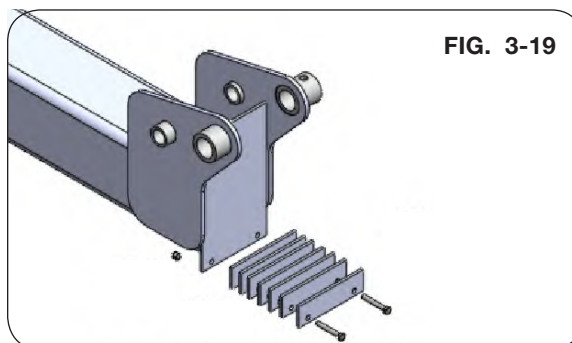

Depth Adjustment

1. Full raise toolbar.
2. Remove the depth collars from the storage bracket.
3. Use 4 1/4" depth collars as a starting depth. Attach depth collars to the toolbar lift cylinders. Adjust as desired.

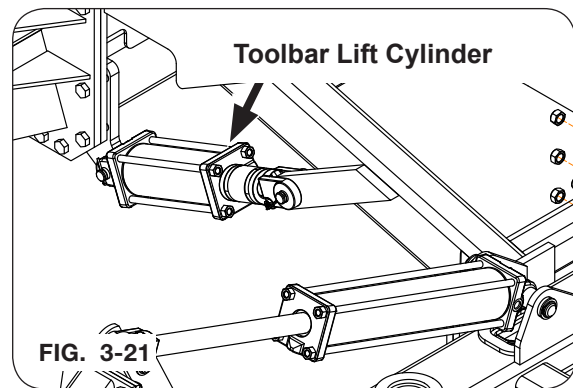
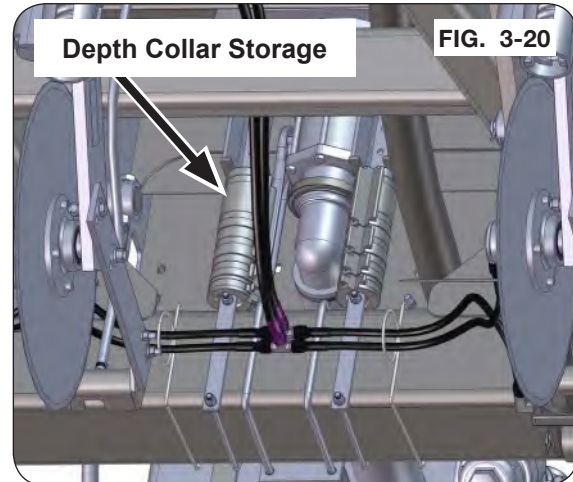

4. Wing latch must move freely in order to operate properly. Keep soil and debris from latch area to allow maximum movement.

CAUTION

- PRIMARY WING FOLD HYDRAULICS MUST BE IN FLOAT POSITION WHILE OPERATING IN THE FILED. THIS ALLOWS THE WINGS TO FLEX UP AND DOWN.
- FAILURE TO RUN IN FLOAT WILL RESULT IN DAMAGE TO THE GULL WING CYLINDERS AND LINKAGE.

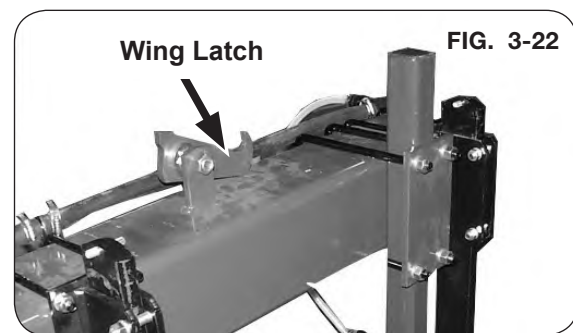

5. Loosen carriage bolts and adjust coulters shanks in flatback until the blade is running at a depth of 4 to 5 inches.

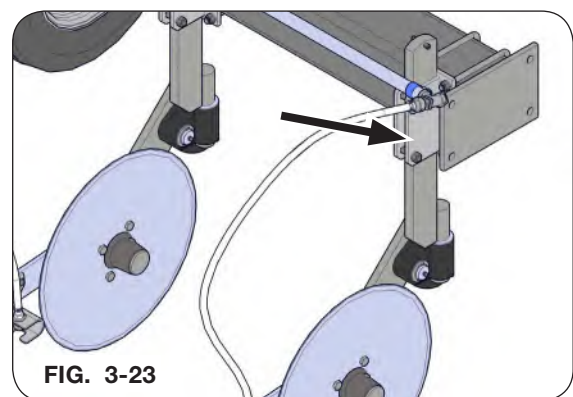

Folding Toolbar

DANGER

- ELECTROCUTION WILL CAUSE SERIOUS INJURY OR DEATH. PERFORM BOOM UNFOLDING AND FOLDING OPERATIONS ONLY IN AREAS WITH ADEQUATE HEIGHT, WIDTH AND LENGTH CLEARANCE. IN PARTICULAR, BE MINDFUL OF LOCATION OF OVERHEAD POWER LINES.

WARNING

- FALLING OR LOWERING EQUIPMENT CAN CAUSE SERIOUS INJURY OR DEATH. KEEP EVERYONE AWAY FROM EQUIPMENT WHEN SUSPENDED, RAISING, OR LOWERING.
1. Toolbar must be completely raised before folding.
 2. Lock the transport lock.



3. Remove depth stops and install transport cylinder stops before folding wings.

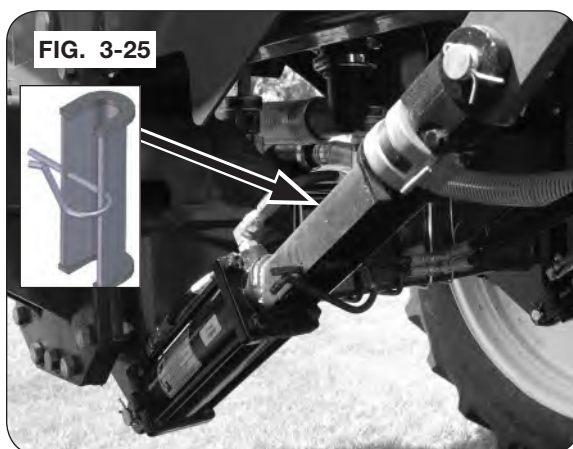

Folding Toolbar

4. If applicable, fold the third wing cylinders.

FIG. 3-26



5. Fold the secondary wing cylinders. Secondary wings swing forward.

FIG. 3-27



FIG. 3-18

Folding Toolbar (continued)

6. Fold the primary wing cylinders. One side will fold up and then the other.



FIG. 3-28



FIG. 3-29

Notes

Section IV
Maintenance

Applicator Maintenance.....4-2
Seasonal Storage.....4-2
Purging A Hydraulic System.....4-3
Lubrication4-4
Filters.....4-6
 Primary Filter.....4-6
 Secondary Filter.....4-6
Winterizing4-7
High-Pressure Coulter Injection System Nozzle Calibration Worksheet4-8
Schematics.....4-10
Wheel, Hub and Spindle Disassembly and Assembly.....4-15
Wheels and Tires.....4-17
 Wheel Nut Torque Requirements.....4-17
 Tire Pressure4-18
 Tire Warranty4-18
Complete Torque Chart
 Grade 54-19
 Grade 84-20
Hydraulic Fittings4-21
Manifold Layouts.....4-22

Applicator Maintenance

DANGER

- ELECTROCUTION WILL CAUSE SERIOUS INJURY OR DEATH. THE APPLICATOR IS NOT INSULATED. KEEP AWAY FROM ALL ELECTRICAL LINES AND DEVICES. ELECTROCUTION CAN OCCUR WITHOUT DIRECT CONTACT.



WARNING

- TIPPING OR MOVEMENT OF THE MACHINE CAN CAUSE SERIOUS INJURY OR DEATH. BE SURE MACHINE IS SECURELY BLOCKED.
- EYE PROTECTION AND OTHER APPROPRIATE PERSONAL PROTECTIVE EQUIPMENT MUST BE WORN WHILE SERVICING IMPLEMENT.
- KEEP HANDS CLEAR OF PINCH POINT AREAS.
- ALWAYS WEAR PERSONAL PROTECTIVE EQUIPMENT WHEN WORKING WITH OR NEAR CHEMICALS. THIS EQUIPMENT INCLUDES, BUT IS NOT LIMITED TO: PROTECTIVE EYE WEAR, GLOVES, SHOES, SOCKS, LONG-SLEEVED SHIRT, AND LONG PANTS. ADDITIONAL PROTECTION MAY BE REQUIRED FOR MANY TYPES OF CHEMICALS.
- AVOID BREATHING SPRAY MIST OR VAPOR.
- WASH HANDS BEFORE EATING, DRINKING, CHEWING GUM, OR USING TOILET.
- NEW HYDRAULIC SYSTEMS OR SYSTEMS THAT HAVE BEEN MAINTAINED MUST BE PURGED OF AIR BEFORE OPERATING OR MOVING MACHINE TO PREVENT SERIOUS INJURY OR DEATH.

CAUTION

- SHARP EDGES ON COULTER BLADES AND KNIVES CAN CAUSE SERIOUS INJURY. BE CAREFUL WHEN WORKING AROUND COULTER BLADES AND KNIVES.

Seasonal Storage

Always open all product valves to remove any fluids and to allow moisture to dry.

Immediately after season is finished, completely wash machine to remove corrosive fertilizer inside and out before storing. When using pressure washers, maintain an adequate distance so not to force water into bearings.

Repaint all areas where paint has been removed to keep rust from developing. Coat areas of coultter blades and knives, if equipped, and coultter posts with rust prohibitive material.

Applicator Maintenance (continued)

Coat exposed cylinder piston rods with rust preventative material if applicable.

Inspect machine for parts that may need to be replaced so they may be ordered in the off season.

Lubricate machine at all points outlined.

Check coultter post blade hubs for free rotation. If blade hubs do not rotate, replace and/or pack bearings with grease. Replace coultter arm if spindle is damaged. (FIG. 4-1)

Check coultter post swivel for free movement. If post swivel does not move, free the swivels and grease. Grease the coultter post swivel until fresh grease purges top or bottom of swivel casting to prevent the coultter pivot seizing on post. (FIG. 4-1) Refer to a "Lubrication" in this section.

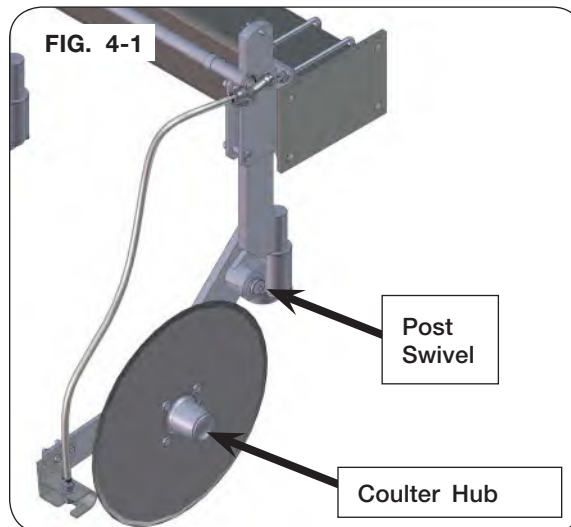

Purging A Hydraulic System

⚠ WARNING

- RELIEVE HYDRAULIC SYSTEM OF ALL PRESSURE BEFORE ADJUSTING OR SERVICING. SEE TRACTOR OPERATOR'S MANUAL FOR PROPER PROCEDURES.
- HIGH-PRESSURE FLUIDS CAN PENETRATE THE SKIN AND CAUSE SERIOUS INJURY OR DEATH. USE CARDBOARD OR WOOD TO DETECT LEAKS IN THE HYDRAULIC SYSTEM. SEEK MEDICAL TREATMENT IMMEDIATELY IF INJURED BY HIGH-PRESSURE FLUIDS.

1. Purge air from system as follows:
 - A. Disconnect the rod end of all cylinders in a circuit. Block up all rod ends of each hydraulic cylinder in each circuit so the rods can completely extend and retract without contacting any other component.
 - B. Pressurize the system and maintain system at full pressure for at least 5 seconds after cylinder rods stop moving. Check that all cylinders have fully extended or retracted.
 - C. Check oil reservoir in hydraulic power source and re-fill as needed.
 - D. Pressurize system again to reverse the motion of step B. Maintain pressure on system for at least 5 seconds after cylinder rods stop moving. Check that cylinders have fully extended or retracted.
 - E. Check for hydraulic leaks using cardboard or wood. Tighten connections according to directions in Torque Specifications in MAINTENANCE section.
 - F. Repeat steps B, C, D, and E 10-12 times.
 - G. De-pressurize hydraulic system and connect cylinder rod clevises to their mating lugs.

Lubrication

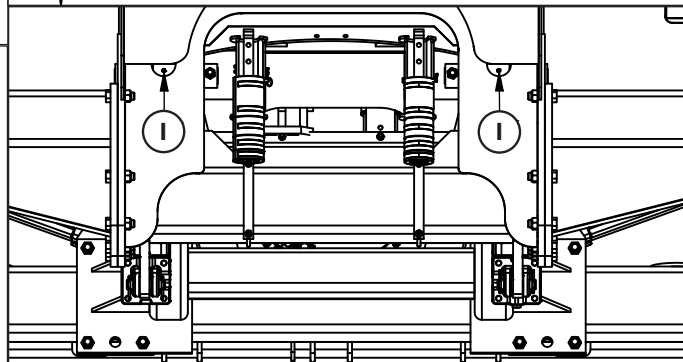
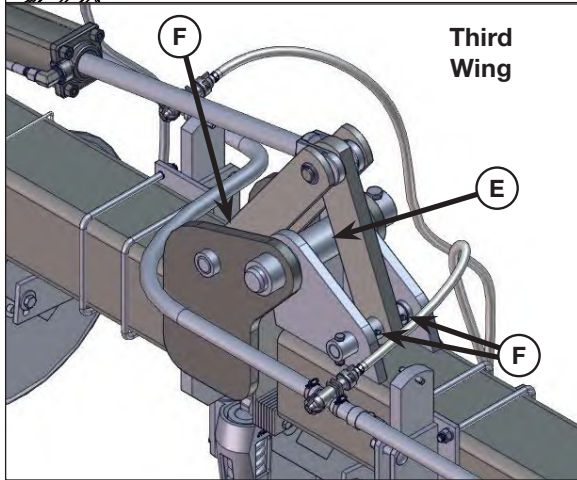
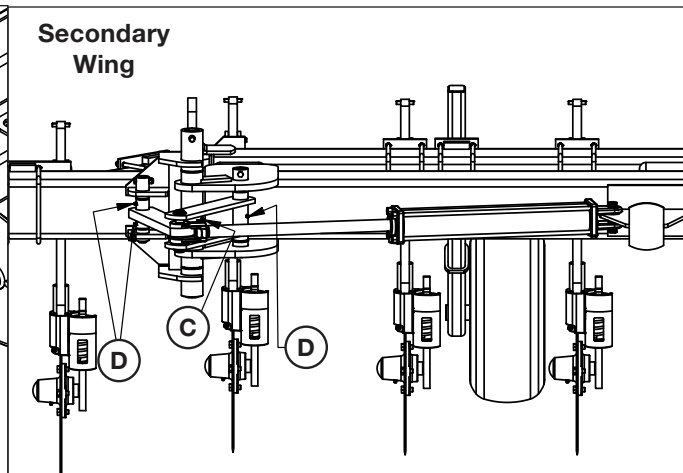
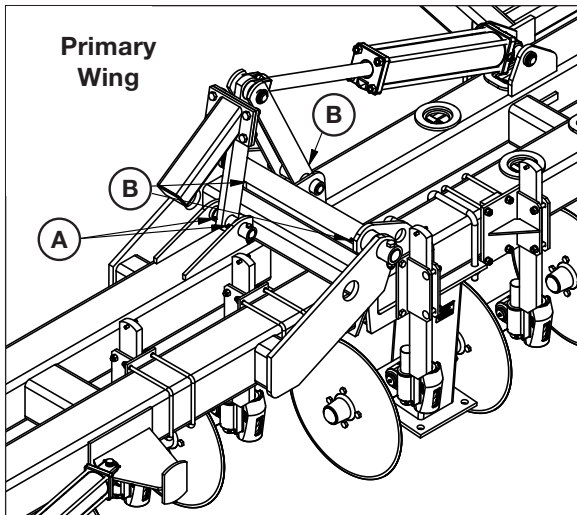

Toolbar Arm Hinge Lubrication

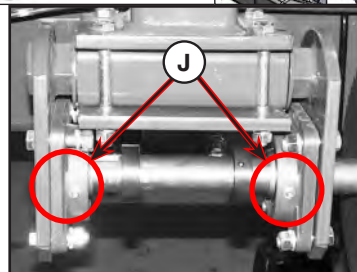
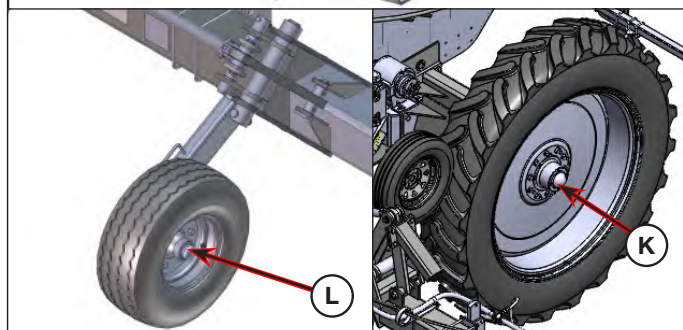
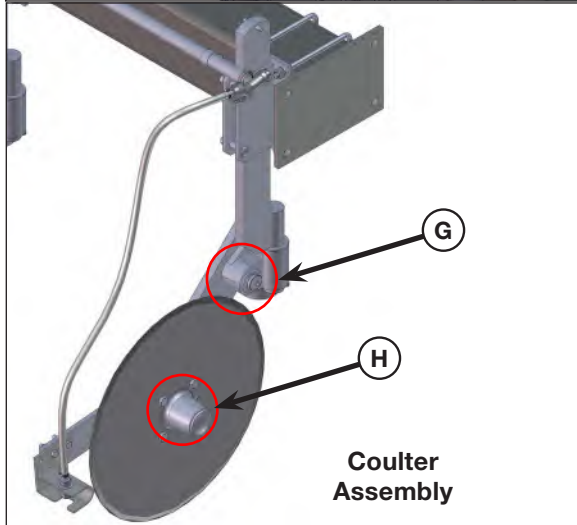
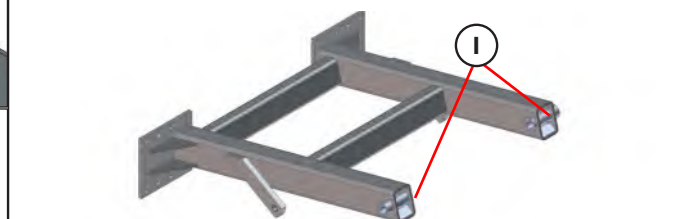

Lubrication (continued)

To keep your applicator in top operating condition and to assure its proper performance and reliability for a long period of time, periodic inspection and lubrication is a must.

Use EP-2 lubricant at the locations described in the chart.

The lubrication locations and recommended schedule are as follows:

ITEM	DESCRIPTION	POINT	QTY.	HOURS
A	Primary Wing Hinge	4	2 Shots	Daily
B	Primary Wing Linkage	6	2 Shots	Daily
C	Secondary Wing Hinge	2	2 Shots	Daily
D	Secondary Wing Linkage	6	2 Shots	Daily
E	Third Wing Hinge	2	2 Shots	Daily
F	Third Wing Linkage	6	2 Shots	Daily
G	Coulter Arm Pivot (per Coulter)	1	1 Shot	Daily
H	Coulter Hub	-	10 Shots	Once Every Season
I	Toolbar Arm Hinge Lubrication	2	2 Shots	Daily
J	Pump Assembly - Pillow Block Bearings	2	2 Shots	Daily
K	Main Frame Transport Wheel Hub	2	Repack	Once Every Season
L	Gauge Wheel Hub	4	Repack	Once Every Season

Filters

This applicator uses a filter to help ensure proper operation. This filter will need to be cleaned periodically during use and prior to applicator storage.

⚠ WARNING

- ALWAYS WEAR PERSONAL PROTECTIVE EQUIPMENT WHEN WORKING WITH OR NEAR CHEMICALS. THIS EQUIPMENT INCLUDES, BUT IS NOT LIMITED TO: PROTECTIVE EYE WEAR, GLOVES, SHOES, SOCKS, LONG-SLEEVED SHIRT, AND LONG PANTS. ADDITIONAL PROTECTION MAY BE REQUIRED FOR MANY TYPES OF CHEMICALS.
- RESIDUAL PRESSURE MAY EXIST IN APPLICATOR PLUMBING EVEN WHEN UNIT IS NOT IN USE. RELIEVE PRESSURE BEFORE SERVICING ANY PLUMBING.

Primary Filter

To clean the filter located at the rear of the machine, next to quick-fill (FIG. 4-9):

1. Rotate the pump inlet valve to <OFF>.
2. Drain the strainer.
3. Unscrew the filter housing by turning counter-clockwise and remove the filter screen.
4. Clean filter by flushing strainer element with water.
5. Reassemble filter, open pump inlet valve, and check for leaks.

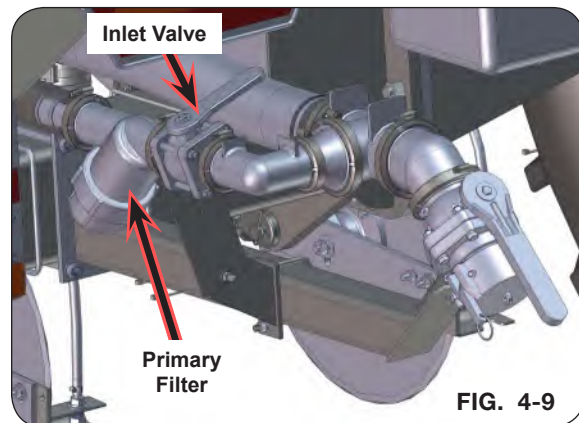

FIG. 4-9

Secondary Filter - For Units With Hydraulic Driven Centrifugal Pump

A secondary filter is located on the tongue near the toolbar electric valves. This filter, similar in construction to the primary filter, is used to eliminate the need for strainers at the tips. To clean this filter, first drain the filter housing. Then unscrew the filter housing and remove the screen. Flush the strainer element with water. After cleaning, reassemble filter and check for leaks. (FIG. 4-10)

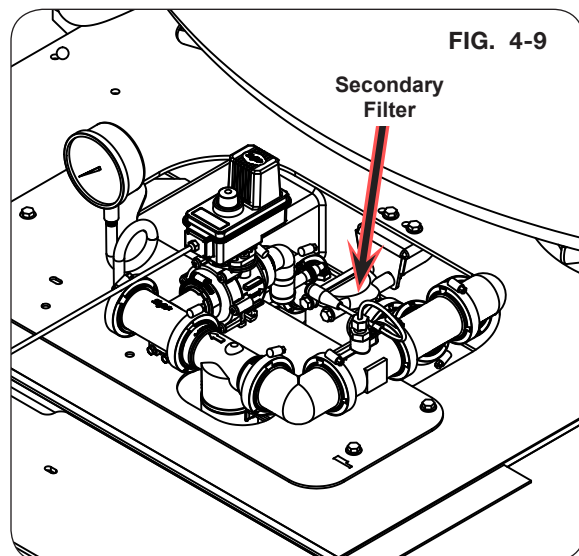

FIG. 4-9

Winterizing

WARNING

- ALWAYS WEAR PERSONAL PROTECTIVE EQUIPMENT WHEN WORKING WITH OR NEAR CHEMICALS. THIS EQUIPMENT INCLUDES, BUT IS NOT LIMITED TO: PROTECTIVE EYE WEAR, GLOVES, SHOES, SOCKS, LONG-SLEEVED SHIRT, AND LONG PANTS. ADDITIONAL PROTECTION MAY BE REQUIRED FOR MANY TYPES OF CHEMICALS.

IMPORTANT

- *Do not allow pump to run dry. Pump damage will result.*

Before storing the applicator in freezing climates, perform the following winterizing procedure:

1. Perform a complete system rinse.
2. Wash the applicator thoroughly inside and out with a high-pressure washer.
3. Remove as much water from the main tank as possible. Close drain valve on main tank after draining.
4. Pour approximately 50 gallons of R.V. antifreeze into main tank.
5. Loosen diaphragm caps on nozzle bodies to relieve pressure and allow excess antifreeze to drain from wings.

High-Pressure Coulter Injection System Nozzle Calibration Worksheet

Calibration of these systems involves two separate sets of calculations. The first being a procedure of setting rate and the second being a procedure of obtaining system pressure.

FIRST:

These systems utilize a positive-displacement, ground-driven, piston pump to establish the GPA (gallon per acre) rate. Because the pump is ground-driven, this rate will be very consistent provided you do not exceed the pumps capacity or pressure ratings (120 PSI Maximum).

SECOND:

The injection system nozzles are what determine system operation pressure at a particular flow rate and ground speed. Because the system requires nozzle pressure in the 60 PSI to 120 PSI range to inject fertilizer into the soil properly, it becomes necessary to size the nozzle correctly to maintain this 60-120 PSI optimum operating pressure at various speeds. In effect, the operating speed is limited by the range of pressure necessary for proper injection system operation. Remember that nozzle size has no affect on rate, only system operating pressure.

High Pressure Injection System Pump Calibration Work sheet

Step 1: Rate Calculation (gallons per acre)
 Actual pounds of nitrogen per acre desired \div percent
 of nitrogen in solution equals pounds of solution per acre
 Actual N \div % of N = lbs. solution per acre

Examples:

100 lbs. of actual N desired \div .28 (% of N in solution) = 357 lbs. per acre
 100 lbs. of actual N desired \div .32 (% of N in solution) = 312 lbs. per acre

Step 2: Pounds per acre of solution \div weight per gallon of solution equal GPA
 (GPA= gallons per acre of solution)
 lbs. solution per acre \div weight per gallon = GPA

Examples:

357 lbs. of 28% N solution \div 10.65 lbs. per gallon = 33.5 GPA
 312 lbs. of 32% N solution \div 11.4 lbs. per gallon = 27.37 GPA

Step 3: Use the John Blue, pump setting, slide-rule chart.
 The standard BLU-JET sprocket combination is 18 to 50.

Step 4: Loaded Radius:
 We recommend using a loaded radius of 10" for the standard BLU-JET tire drive wheel when used with the John Blue LM 4450 pump.
 Add 1/2" to the loaded radius if soil builds up on the small tire in wet conditions.

High-Pressure Coulter Injection System Nozzle Calibration Worksheet

Step 5: Swath width is the number of rows being applied (Example: A 15 row 30" machine will cover 16 rows.) times the spacing between the rows.

$$\begin{aligned} \text{Rows} \times \text{Spacing} &= \text{Swath width} \\ 16 \text{ rows} \times 30" &= 480" \text{ (swath width)} \end{aligned}$$

Step 6: Example:

1. Using the chart, align loaded radius (10") with 18 to 50 sprocket combination setting.
2. Using the chart, align swath width (480") with arrow under sprocket ratio.
3. Using the chart, GPA rate (LM4450) pump) from step 2 above will align with correct pump setting.

Once the correct pump setting has been obtained from the pump calibration work sheet it becomes necessary to select a nozzle size that will result in a system operating pressure that falls within the recommended range of 60 PSI to 120 PSI. It is important to remember that GPA rate will not be affected by changing nozzle sizes. The only way the GPA rate will change is if you change pump settings. A gauge is provided to double check calculations and monitor pressure during operation.

To simplify calibration we supplied a chart based on 28% nitrogen solution in 30" row spacings.

Example: Using the 30" spacing chart, with 7 MPH as the target operating speed and 115 lbs. N/acre as the target rate; you can see that nozzle size 4916-95 will produce 80 PSI @ 7 MPH. Also if you look under the 8 MPH column you will see that this nozzle size will produce 100 PSI.

It is recommended that a mid-range pressure of 80 to 100 PSI is used to allow for speed variances in field operation, if possible.

It is recommended that the stream stabilizer nozzle inserts always be used with these nozzles to improve the solid-stream characteristics of the spray pattern and consequently the injection and over spray reduction characteristics of nozzle. These stainless steel nozzle orifices are commercially available almost everywhere and there are several sizes available between those on our chart if needed. It is recommended that a fine line (80 mesh) stainer be used on extremely low rate applications to prevent plugging nozzles.

Helpful Hints:

If the actual applied rate is not correct after system calibration has been completed, the cause is probably slippage of the pump ground drive wheel tire. To remedy this, you should increase the spring pressure on the tire. If extremely difficult conditions continue to cause slippage, increase slightly.

Schematics

Main Electrical Harness 10' - 5 Wire, 7 Pin & Dust Cap (Part #JAP3142)

- A. CONNECTOR: PACKARD, FLAT 6 M-TERMINAL WEATHER-PACK SHROUD
- B. CABLE: 5-WIRE 16AWG, (WHT, YEL, RED, GRN, BRN)
- C. CONNECTOR: 7 F-TERMINAL PLUG CONFORMING TO SAE STANDARD J560
- D. DUST CAP: COLE HERSEE 11750 OR EQUAL, (AP2829)

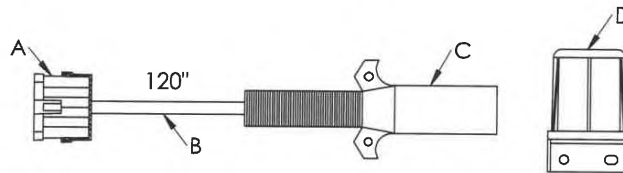

6 M-TERMINAL WEATHER-PACK SHROUD		
PIN #	DESCRIPTION	WIRE COLOR
1	GROUND	WHITE
3	LEFT TURN/FLASHING	YELLOW
4	STOP LAMPS	RED
5	RIGHT TURN/FLASHING	GREEN
6	TAIL LAMPS	BROWN

7 F-TERMINAL PLUG		
PIN #	DESCRIPTION	WIRE COLOR
1	GROUND	WHITE
3	LEFT TURN/FLASHING	YELLOW
4	STOP LAMPS	RED
5	RIGHT TURN/FLASHING	GREEN
6	TAIL LAMPS	BROWN

Light Electrical Harness 17' - 5 Wire (Part #JAP3197)

RIGHT REAR RED LAMP		
PIN #	DESCRIPTION	WIRE COLOR
1	GROUND	WHITE
2	STOP LAMPS	RED
3	TAIL LAMPS	BROWN

LEFT REAR RED LAMP		
PIN #	DESCRIPTION	WIRE COLOR
1	GROUND	WHITE
2	STOP LAMPS	RED
3	TAIL LAMPS	BROWN

RIGHT REAR AMBER LAMP		
PIN #	DESCRIPTION	WIRE COLOR
1	GROUND	WHITE
2	RIGHT TURN/FLASHING	GREEN

LEFT REAR AMBER LAMP		
PIN #	DESCRIPTION	WIRE COLOR
1	GROUND	WHITE
2	LEFT TURN/FLASHING	YELLOW

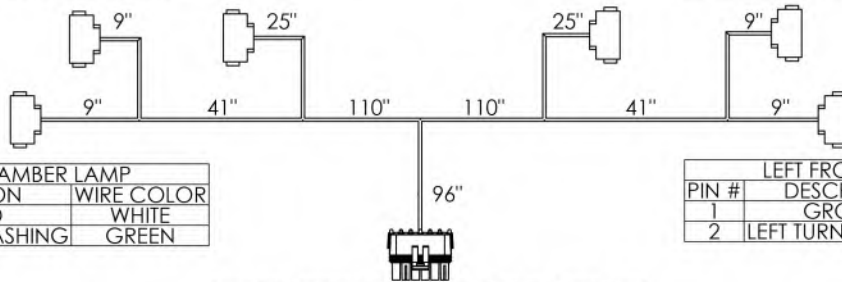

RIGHT FRONT AMBER LAMP		
PIN #	DESCRIPTION	WIRE COLOR
1	GROUND	WHITE
2	RIGHT TURN/FLASHING	GREEN

LEFT FRONT AMBER LAMP		
PIN #	DESCRIPTION	WIRE COLOR
1	GROUND	WHITE
2	LEFT TURN/FLASHING	YELLOW

6 F-TERMINAL WEATHER-PACK TOWER		
PIN #	DESCRIPTION	WIRE COLOR
1	GROUND	WHITE
2	(OPEN)	
3	LEFT TURN/FLASHING	YELLOW
4	STOP LAMPS	RED
5	RIGHT TURN/FLASHING	GREEN
6	TAIL LAMPS	BROWN

Schematics — ACE 205 Variable Rate Pump Wire Harness (9503472)

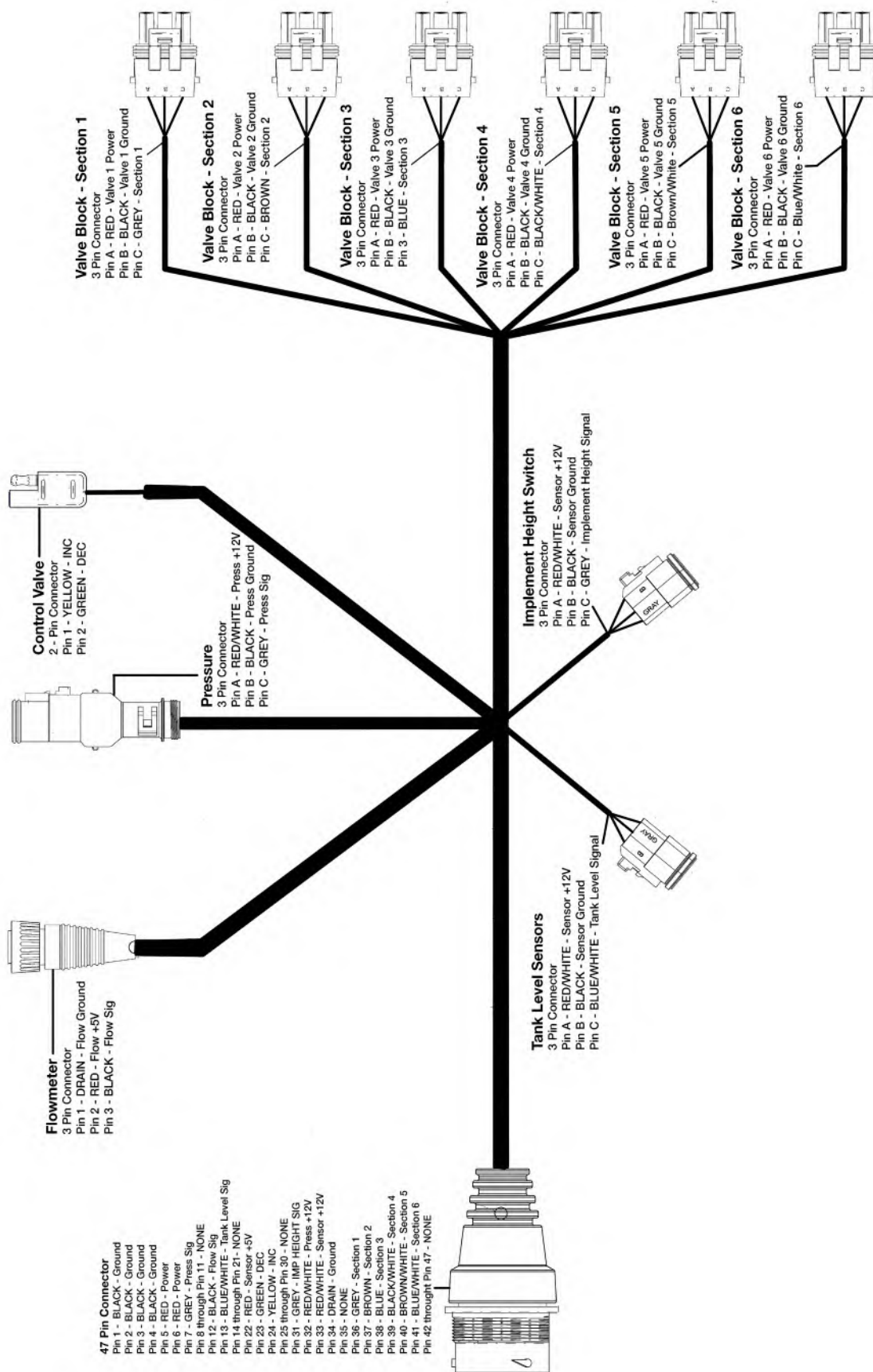

Schematics — Controller Wire Harness (9503471)

47 Pin Connector

Pin 1 - BLACK - HC Ground	Pin 24 - YELLOW
Pin 2 - BLACK - Sensor RTN	Pin 25 through Pin 31 - NONE
Pin 3 - BLACK - Sensor RTN	Pin 32 - RED/WHITE
Pin 4 - BLACK - HC Ground	Pin 33 - RED/WHITE
Pin 5 - RED	Pin 34 - BLACK
Pin 6 - RED	Pin 35 - NONE
Pin 7 - GREY	Pin 36 - GREY
Pin 8 through Pin 11 - NONE	Pin 37
Pin 12 - GREY	Pin 38
Pin 13 through Pin 14 - NONE	Pin 39
Pin 15 - RED - HC Power	Pin 40
Pin 16 through Pin 21 - NONE	Pin 41
Pin 22 - RED	Pin 42 through Pin 47 - NONE
Pin 23 - GREEN	

3 Pin Connector

Pin 1 - NONE
Pin 2 - NONE
Pin 3 - GREY - Pressure Signal



Console 16 Pin Connector

Pin 1 - BLACK - HC Ground
Pin 2 - BROWN - Section 2 Signal
Pin 3 - YELLOW - Valve INC
Pin 4 - GREEN - Valve DEC
Pin 5 - BLUE - Section 3 Signal
Pin 6 - GREY - Section 1 Signal
Pin 7 - BLACK/WHITE - Section 4 Signal
Pin 8 - BROWN/WHITE - Section 5 Signal
Pin 9 - BLUE/WHITE - Section 6 Signal
Pin 10 - NONE
Pin 11 - BLACK - Sensor RTN
Pin 12 - RED - Sensor 5V Power
Pin 13 - GREY - Flow Signal
Pin 14 - RED - HC Power
Pin 15 - BLACK - HC Ground
Pin 16 - RED - HC Power

Schematics — Wire Harness (9503387)

PIN	Color	Size	TO
1	BLACK	18 GA	J3-1
2	BLACK	14 GA	S1-3
3	RED	18 GA	F1-A
4	RED	14 GA	J4-2
5			
6	CR-RED	18 GA	J4-9
7	CR-BLK	18 GA	J4-3
8	CR-YEL	18 GA	J4-4
9	CR-GRN	18 GA	J4-10

PIN	Color	Size	TO
A	RED	18 GA	J1-3
B	RED	18 GA	J3-2

PIN	Color	Size	TO
1	BLACK	18 GA	J1-1
2	RED	18 GA	F1-B

PIN	WIRE NO.	Color	Size	TO
1		BLACK	14 GA	S1-2
2		RED	14 GA	J1-4
3		CR-BLK	18 GA	J1-7
4		CR-YEL	18 GA	J1-8
5				
6		BLUE	18 GA	J2-C
7				
8		RED	14 GA	J2-B
9		CR-RED	18 GA	J1-6
10		CR-GRN	18 GA	J1-9
11				
12				

PIN	WIRE NO.	Color	Size	TO
A		BLACK	18 GA	S1-1
B		RED	14 GA	J4-8
C		BLUE	18 GA	J4-6

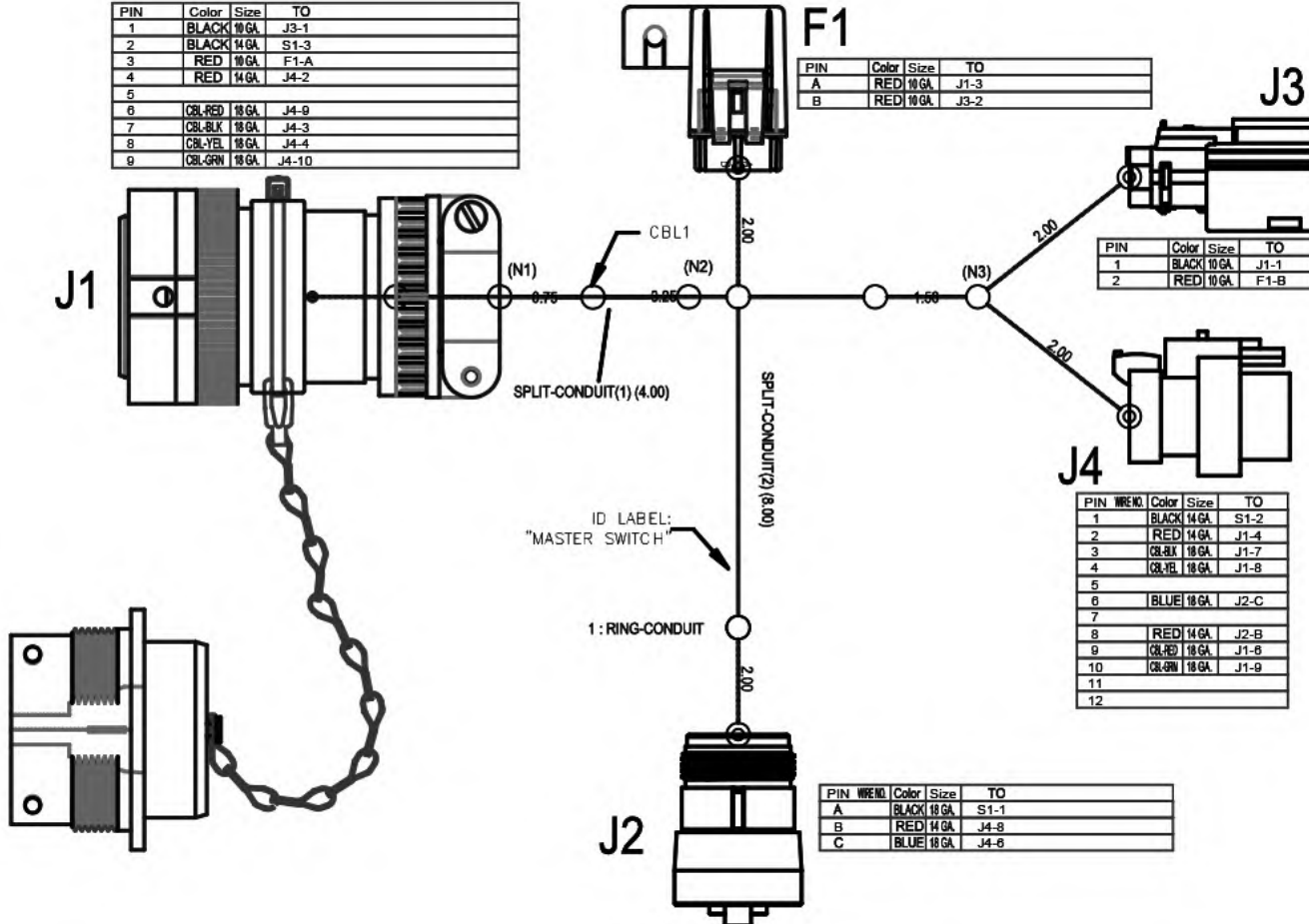

Schematics — ISOBUS Controller ECU Wire Harness (9008095)

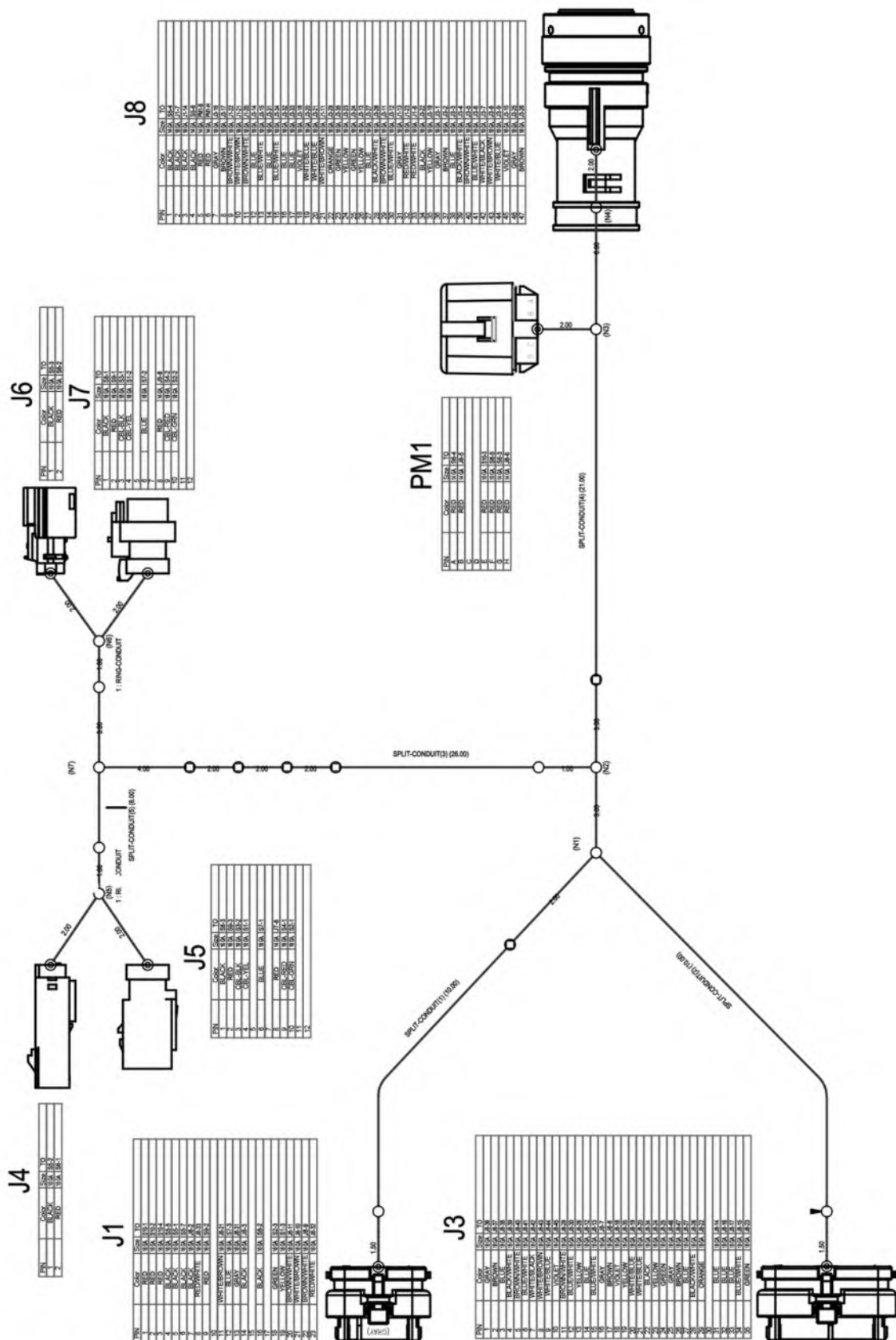

Schematics — Foot Switch Wire Harness (9503390)

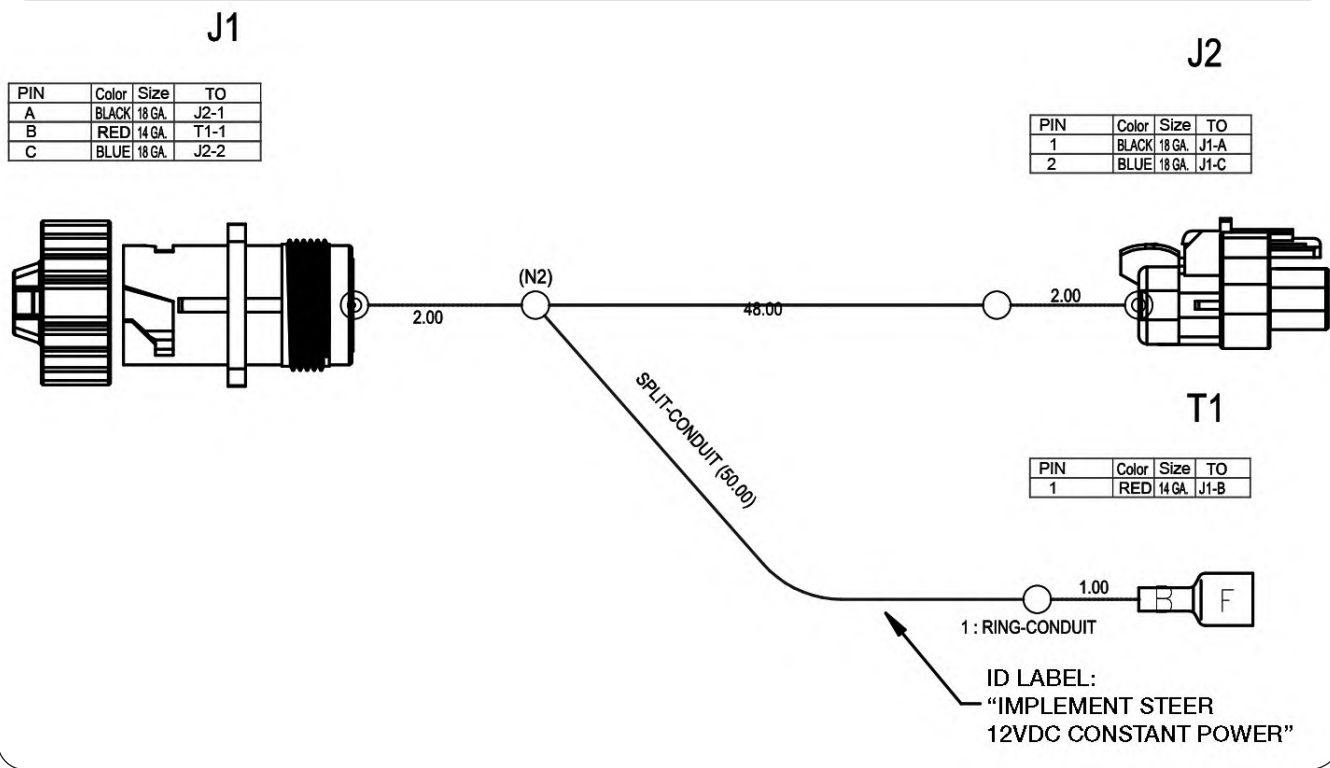

Schematics — 450 Controller, Console Wire Harness (9007549)

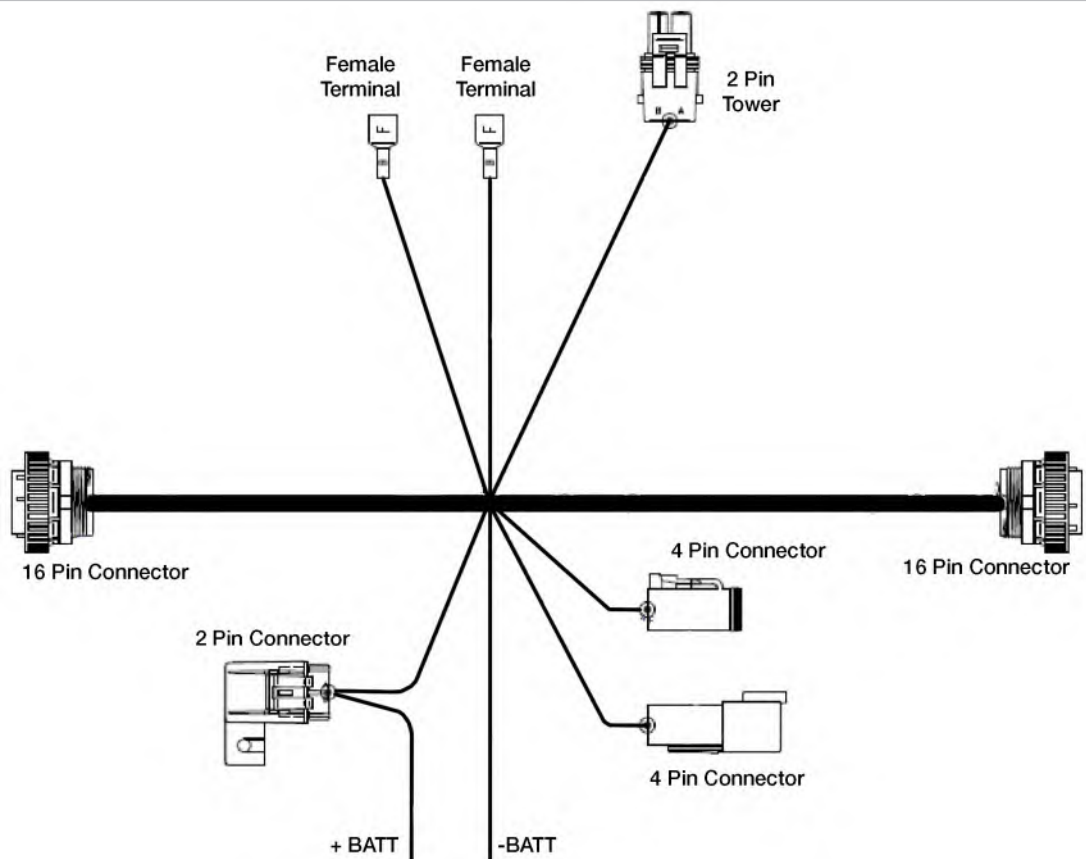

Wheel, Hub and Spindle Disassembly and Assembly

WARNING

- TIPPING OR MOVEMENT OF THE MACHINE CAN CAUSE SERIOUS INJURY OR DEATH. BE SURE MACHINE IS SECURELY BLOCKED.

- FALLING OBJECTS CAN CAUSE SERIOUS INJURY OR DEATH. DO NOT WORK UNDER THE MACHINE AT ANY TIME WHILE BEING HOISTED. BE SURE ALL LIFTING DEVICES AND SUPPORTS ARE RATED FOR THE LOADS BEING HOISTED. THESE ASSEMBLY INSTRUCTIONS WILL REQUIRE SAFE LIFTING DEVICES UP TO 30,000 LBS. SPECIFIC LOAD RATINGS FOR INDIVIDUAL LOADS WILL BE GIVEN AT THE APPROPRIATE TIME IN THE INSTRUCTIONS.

- EYE PROTECTION AND OTHER APPROPRIATE PERSONAL PROTECTIVE EQUIPMENT MUST BE WORN WHILE SERVICING IMPLEMENT.

- KEEP HANDS CLEAR OF PINCH POINT AREAS.

CAUTION

- IMPROPERLY TORQUED WHEEL NUTS/BOLTS CAN CAUSE A LOSS OF IMPLEMENT CONTROL AND MACHINE DAMAGE. TORQUE WHEEL NUTS/BOLTS TO VALUES IN TABLE. CHECK TORQUE BEFORE USE, AFTER ONE HOUR OF UNLOADED USE OR AFTER FIRST LOAD, AND EACH LOAD UNTIL WHEEL NUTS/BOLTS MAINTAIN TORQUE VALUE. CHECK TORQUE EVERY 10 HOURS OF USE THERE-AFTER. AFTER EACH WHEEL REMOVAL START TORQUE PROCESS FROM BEGINNING. WARRANTY DOES NOT COVER FAILURES CAUSED BY IMPROPERLY TORQUED WHEEL NUTS/BOLTS.

IMPORTANT

- *Remove only one wheel and tire from a side at any given time in the following procedure.*

1. Hitch implement to tractor. Park on a firm, level surface. Set the tractor's parking brake, shut off engine and remove key.



2. Use a safe lifting device rated at 30,000 lbs. to support the weight of your implement. Place the safe lifting device under the axle closest to the tire.
3. Use a 3,000 lbs. safe lifting device to support the wheel and tire during removal.
4. If only removing wheel and tire, skip to Step 8; otherwise continue with Step 4.

Remove the hardware retaining the hubcap. Next, remove the hubcap, gasket, cotter pin, castle nut and spindle washer. Remove hub with bearings from old spindle using a 200 lbs. lifting device.

Wheel, Hub and Spindle Disassembly and Assembly (continued)

5. Inspect the spindle and replace if necessary. If spindle does not need to be replaced, skip to Step 6; otherwise continue with Step 5.

Remove the bolt and lock nut that retain the spindle to the axle. Using a lifting device rated for 150 lbs., remove the old spindle. Coat spindle shaft with anti-seize lubricant prior to installation. Reuse bolt and lock nut to retain spindle to axle. Torque as outlined in Maintenance Section.

6. Remove seal and inspect bearings, spindle washer, castle nut and cotter pin. Replace if necessary. Pack both bearings with Extreme Pressure NLGI #2 grease and reinstall inner bearing. Install new seal in hub with garter spring facing inward to the hub by tapping on flat plate that completely covers seal while driving it square to hub. Install until flush with back face of hub. Using a 200 lb. rated lifting device, install hub assembly onto spindle. Install outer bearing, spindle washer and castle nut.

IMPORTANT

- *Do not use an impact wrench!*
7. Slowly tighten castle/slotted nut while spinning the hub until hub stops rotating. Turn castle nut counterclockwise until the hole in the spindle aligns with the next notch in castle nut. Hub should spin smoothly with minimal drag and no end play. If play exists, tighten to next notch of castle nut. If drag exists, then back castle nut to next notch. Spin and check again. Install cotter pin. Clean face for hub cap gasket and install gasket, grease- filled hub cap and retain hubcap with hardware removed. Tighten hubcap hardware in alternating pattern.
 8. Attach the wheel(s) and tire(s) to the hub using the same rated safe lifting device for removal. Tighten wheel nuts to appropriate requirements and recheck as outlined in the Wheels and Tires section of this manual.
 9. Raise implement, remove lifting device and lower tire to the ground.

Wheels and Tires

Wheel Nut Torque Requirements

⚠ CAUTION

- **IMPROPERLY TORQUED WHEEL NUTS/BOLTS CAN CAUSE A LOSS OF IMPLEMENT CONTROL AND MACHINE DAMAGE. TORQUE WHEEL NUTS/BOLTS TO VALUES IN TABLE. CHECK TORQUE BEFORE USE, AFTER ONE HOUR OF UNLOADED USE OR AFTER FIRST LOAD, AND EACH LOAD UNTIL WHEEL NUTS/BOLTS MAINTAIN TORQUE VALUE. CHECK TORQUE EVERY 10 HOURS OF USE THEREAFTER. AFTER EACH WHEEL REMOVAL START TORQUE PROCESS FROM BEGINNING. WARRANTY DOES NOT COVER FAILURES CAUSED BY IMPROPERLY TORQUED WHEEL NUTS/BOLTS.**

Failure to check torque before first load may damage wheel nut/bolt seats. Once seats are damaged, it will become impossible to keep nuts/bolts tight. Tighten nuts/bolts to applicable torque value shown in table. Start all nuts/bolts by hand to prevent cross threading. Torque nuts/bolts in the recommended sequence as shown in Diagrams 1, 2 & 3.

WHEEL HARDWARE	
SIZE	FOOT-POUNDS
1/2"-20(UNF) Grade 5	75 Ft.-Lbs.
3/4"-16(UNF) Grade 8	365 Ft.-Lbs.

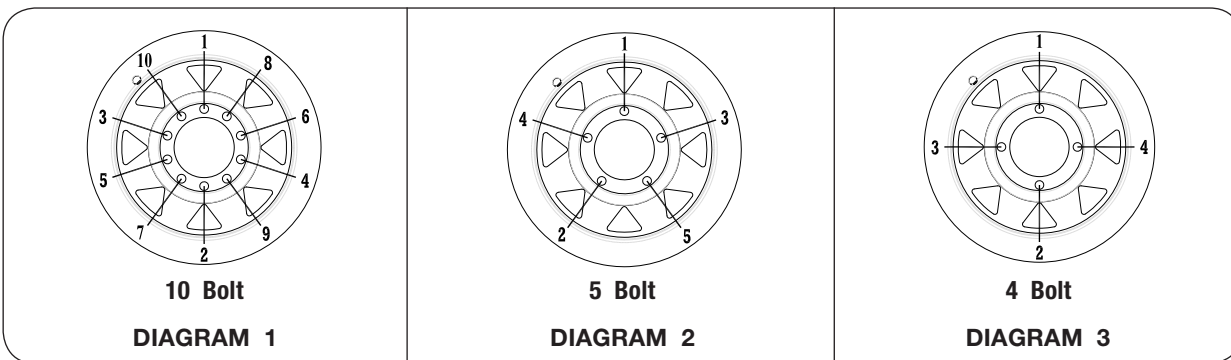

Wheels and Tires (continued)

Tire Pressure

The following is to be used as a general guide for tire inflation and figures can vary depending on specific brand of tire used. It is important that tires are inspected after unit is loaded. The tire should stand up with no side-wall buckling or distress as tire rolls. Record the pressure needed to support the full load and maintain this pressure to achieve proper tire life. Do not exceed maximum recommended tire pressure.

Tire Pressure for Blu-Jet Liquid Applicators			
Tire Make	Tire Size	Load Index / Ply	
		Rating	Max PSI
Mitas	VF380/90R46 R-1	173D	64
Goodyear	320/90R46 R-1	159D	64
Goodyear	12.4x38 R-1	14-Ply	56
Carlisle	20.5x8.0B10	F-Ply	35
	145/12	Load Range D	65

(All tire pressures in psi)

Tire Warranty

For questions regarding new tire warranty, please contact your local original equipment tire dealer. Used tires carry no warranty. Following are phone numbers and Websites for your convenience:

Carlisle/Ironman www.carlisletire.com
 Phone 800-260-7959
 Fax 800-352-0075

Continental/Mitas www.mitas-tires.com
 Phone 704-542-3422
 Fax 704-542-3474

Complete Torque Chart

Capscrews - Grade 5

NOTE:

- Grade 5 capscrews can be identified by three radial dashes on the head.
- For wheel torque requirements, refer to Wheels and Tires.
- Tighten U-bolts evenly and equally to have the same number of threads exposed on each end.

SIZE	FOOT POUNDS	NEWTON METERS
1/4-20 1/4-28	8-10 9-11	11-13 12-15
5/16-18 5/16-24	15-17 17-19	20-23 23-26
3/8-16 3/8-24	25-28 28-31	34-38 38-42
7/16-14 7/16-20	40-45 45-50	54-61 61-68
1/2-13 1/2-20	62-68 68-75	84-92 92-102
9/16-12 9/16-18	90-98 100-110	122-133 134-148
5/8-11 5/8-18	120-135 124-137	162-183 168-186
3/4-10 3/4-16	200-220 210-230	270-300 285-310
7/8-9 7/8-14	330-350 360-380	425-475 460-515
1-8 1-14	500-525 540-560	675-710 730-760
1 1/8-7 1 1/8-12	600-635 665-700	815-860 920-950
1 1/4-7 1 1/4-12	850-895 940-990	1150-1215 1275-1340
1 3/8-6 1 3/8-12	1125-1175 1280-1335	1525-1590 1735-1810
1 1/2-6 1 1/2-12	1500-1560 1685-1755	2035-2115 2285-2380

IMPORTANT

- Follow these torque recommendations except when specified in text.

Complete Torque Chart

Capscrews - Grade 8

NOTE:

- Grade 8 capscrews can be identified by six radial dashes on the head.
- For wheel torque requirements, refer to Wheels and Tires.
- Tighten U-bolts evenly and equally to have the same number of threads exposed on each end.



SIZE	FOOT POUNDS	NEWTON METERS
5/16-18	20-22	27-30
5/16-24	21-23	28-31
3/8-16	35-39	47-53
3/8-24	36-41	49-55
7/16-14	54-58	73-78
7/16-20	55-60	75-80
1/2-13	82-88	110-120
1/2-20	94-99	125-135
9/16-12	127-134	170-180
9/16-18	147-155	199-210
5/8-11	160-170	215-230
5/8-18	165-175	225-235
3/4-10	280-295	380-400
3/4-16	330-365	445-495
7/8-9	410-430	555-580
7/8-14	420-440	570-595
1-8	630-650	850-880
1-14	680-700	920-950
1 1/8-7	900-930	1220-1260
1 1/8-12	930-950	1260-1290
1 1/4-7	1250-1300	1695-1760
1 1/4-12	1280-1320	1735-1790

IMPORTANT

- *Follow these torque recommendations except when specified in text.*

Hydraulic Fittings - Torque and Installation

SAE Flare Connection (J. I. C.)

1. Tighten nut with finger until it bottoms the seat.
2. Using a wrench, rotate nut to tighten. Turn nut 1/3 turn to apply proper torque.

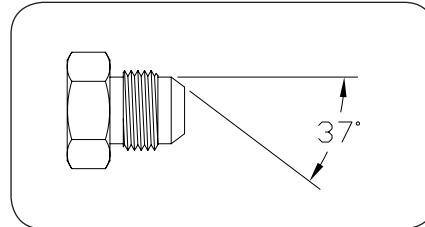

SAE Straight Thread O-Ring Seal

1. Back off jam nut and washer to expose smooth surface for O-ring seal.
2. Lubricate o-ring.
3. Thread into port until washer bottoms onto spot face.
4. Position elbows by backing up adapter.
5. Tighten jam nut.

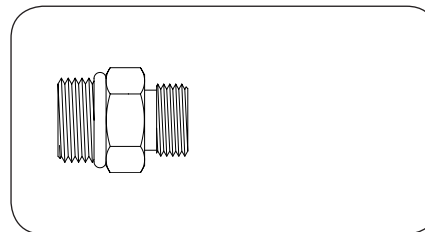

Manifold Layout — 23 Row Unit with Ground Drive Pump

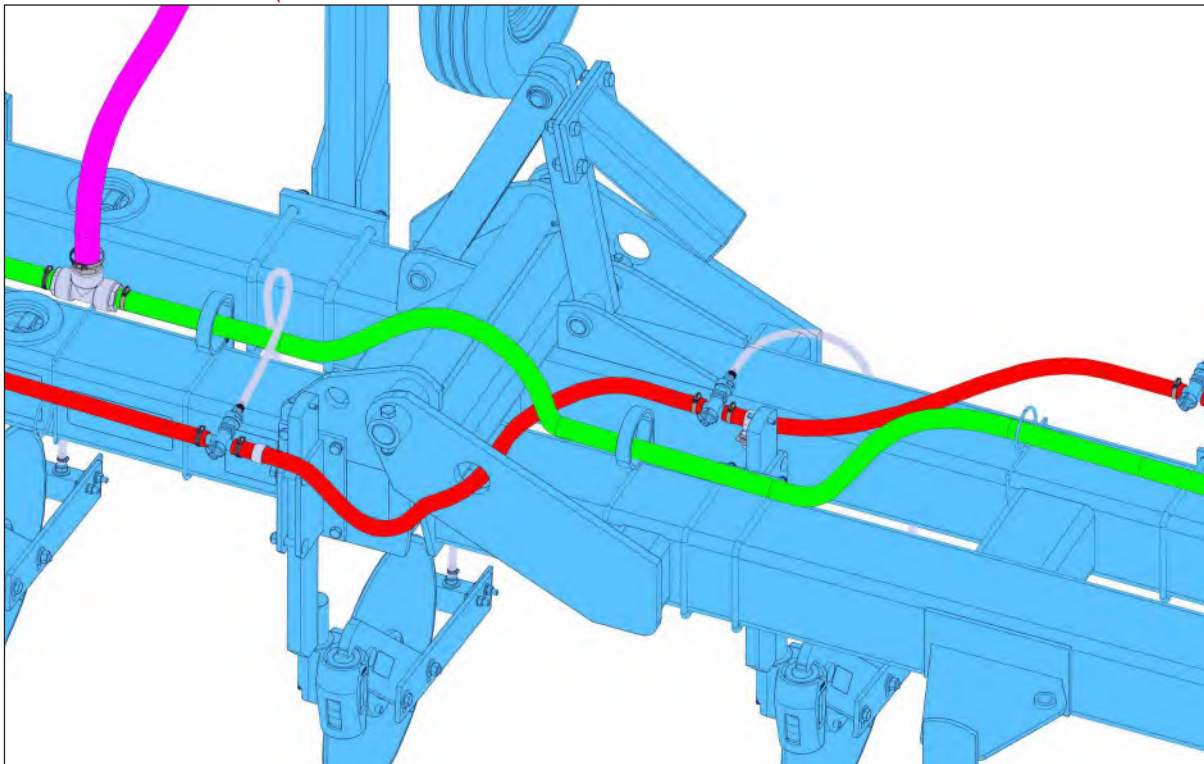
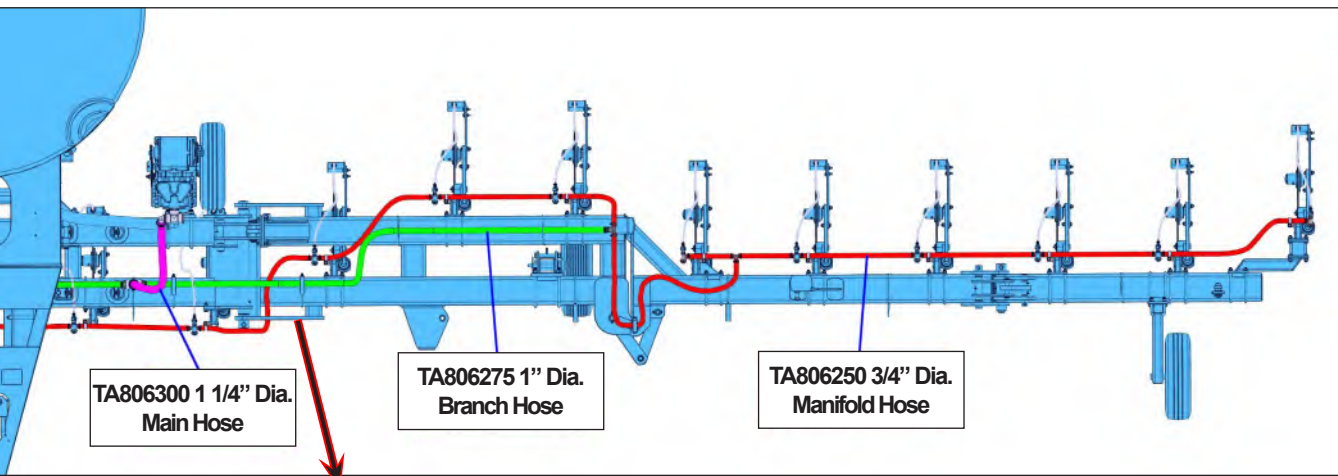
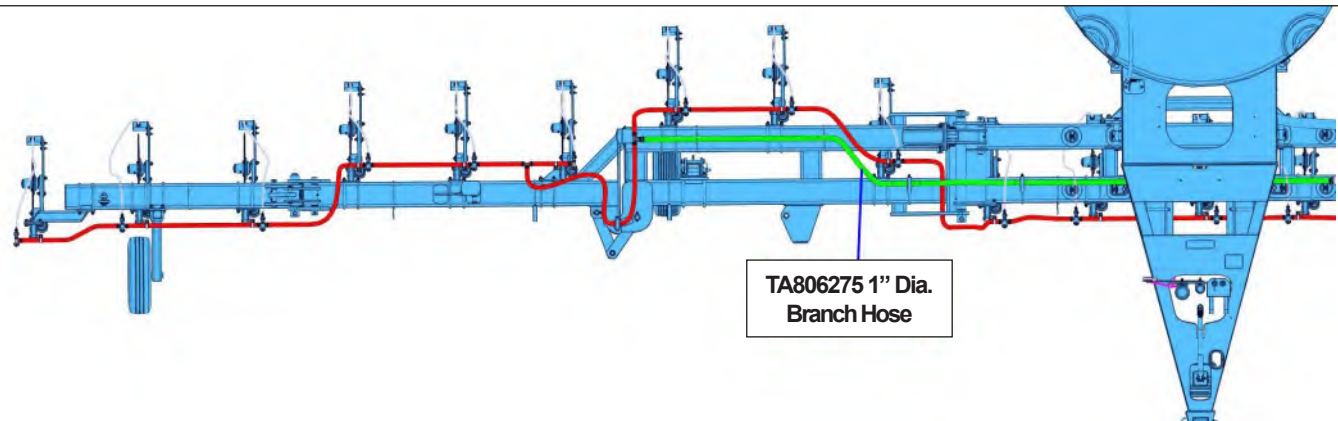

Manifold Layout — 25 Row Unit with Ground Drive Pump

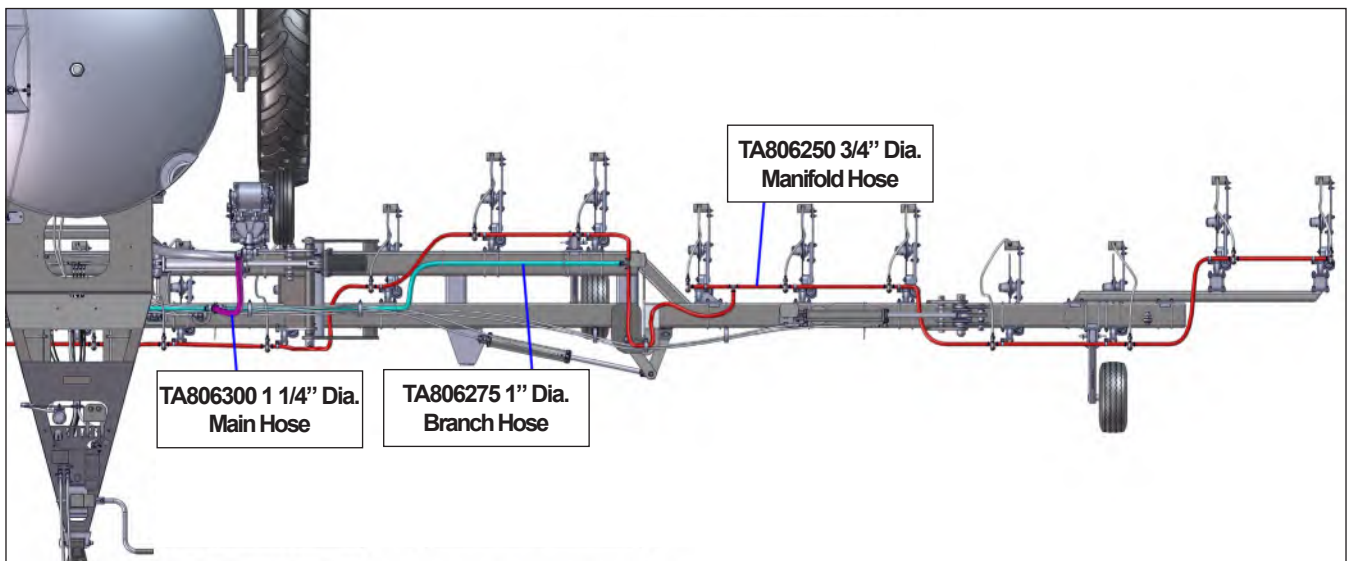
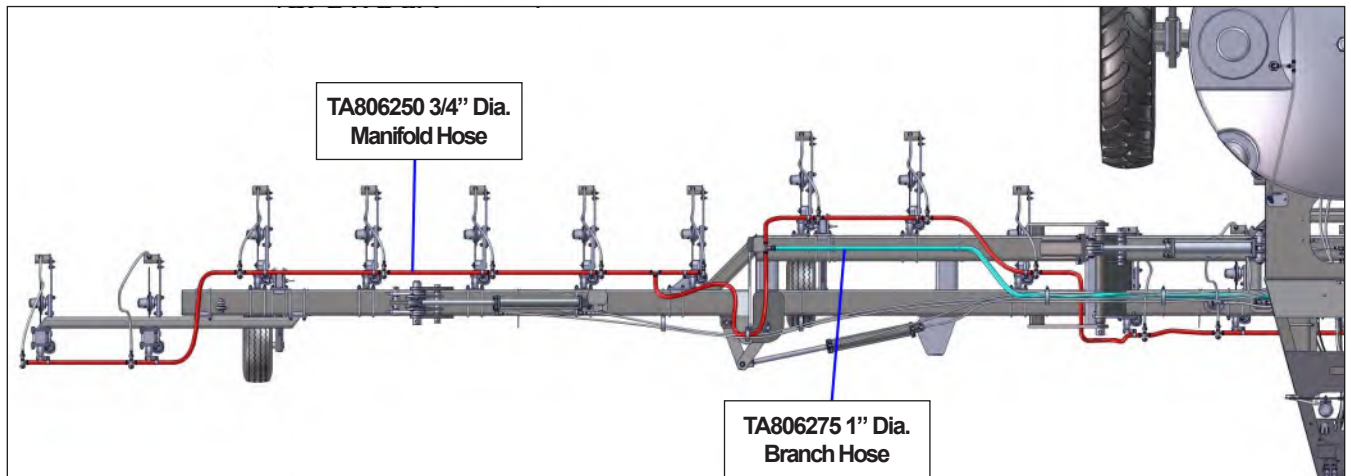

Notes

SECTION V — Parts

AT4615 Main Frame	5-2
Hitch, Transport Chain, Manual Holder and Jack Components.....	5-4
Decals.....	5-6
Clean Water Tank Components.....	5-8
Wheel/Axle, 120" Single, 380/90R46.....	5-9
Hub and Spindle Components	5-10
Double Tube Toolbar - Center Section & Gull Wing Components.....	5-12
Single Tube Toolbar - Center Section & Gull Wing Components.....	5-13
Primary Wing Components (Double Tube Toolbar).....	5-14
Primary Wing Components (Single Tube Toolbar).....	5-16
Secondary Wing Components (Double Tube Toolbar)	5-18
Secondary Wing Components (Single Tube Toolbar).....	5-20
Third Wing Components (Double Tube Toolbar).....	5-22
Wing Extension Components (Single Tube Toolbar).....	5-24
Coulter Offset Mounting Bracket, 10" x 4" (JAAM2180).....	5-25
Coulter Offset Mounting Bracket, 15" x 4" (JAAM2721).....	5-26
Coulter 45° Angled Mounting Bracket (JAAM2436).....	5-27
Coulter Flatback Centered Mounting Bracket (JAAM2821).....	5-28
Coulter Flatback Centered Mounting Bracket (JAAM2646).....	5-29
Coulter Flatback Offset Mounting Bracket (JAAM2822)	5-30
Offset Mounting Bracket, 45" x 4" (JAAM2737)	5-31
Offset Mounting Bracket, 25" x 4" (JAAM2739)	5-32
Stagger Flatback Spacer (JAAM2740).....	5-32
Bolt-On Coulter Bar Assembly (JAAM2908).....	5-33
Gauge Wheel Legs RH/LH Pair, Vertical Pin Adjust	5-34
Super 1200 Coulter Assembly Components (JAAM2730).....	5-36
Coulter Arm, Hub & Knee Components (JAM2799)	5-37
Hub Assembly, 4-Bolt Components (JAP2707)	5-38
Coulter Blade (JAP2840).....	5-39
Narrow Fold Transport Coulter Option (43468) (Double Tube Toolbar).....	5-40
Narrow Fold Transport Coulter Option (43679) (Single Tube Toolbar)	5-42
Jetstream Coulter Knife Assembly Components (JAAM3356).....	5-44
Jetstream Liquid Assembly Components; Tee-Jet Check (JAAM3353); Low Rate (JAAM3355).....	5-46
Lighting Components - For 15, 20, & 30" Spacing.....	4-48
Lighting Components - For 18" Spacing.....	4-50
Hitch Hydraulic Components (Double Tube Toolbar).....	5-52
Hitch Hydraulic Components (Single Tube Toolbar).....	5-54
Double Tube Toolbar Gull Wing & Relief Valve Hydraulic Components.....	5-56
Single Tube Toolbar Gull Wing & Relief Valve Hydraulic Components.....	5-58
Primary Wing Hydraulic Components (Double Tube Toolbar).....	5-60
Primary Wing Hydraulic Components (Single Tube Toolbar).....	5-61
Toolbar Lift Hydraulic Components (Double Tube Toolbar).....	5-62
Toolbar Lift Hydraulic Components (Single Tube Toolbar).....	5-64
Secondary Wing Hydraulic Components (Double Tube Toolbar).....	5-65
Secondary Wing Hydraulic Components (Single Tube Toolbar).....	5-66
Third Wing Hydraulic Components (Double Tube Toolbar).....	5-67
Single & Double Pump Drive Components.....	5-68
Pump Drive Package (JPKG00181).....	5-70
40 Tooth Sprocket & Roller Chain Components	5-72
50 Tooth Sprocket & Roller Chain Components	5-73
Bottom Filling Plumbing Components	5-74
ACE 205 Variable Rate Pump.....	5-76
Ball Valve Components	5-79
Manifold Components.....	5-80
Manifold Components — Gauge & Mounting Components	5-82
Manifold Layout—Drive Pump, Fittings & Hoses (Center Section w/Double Tube Frame)	5-84
Manifold Layout—Drive Pump, Fittings & Hoses (Center Section w/Single Tube Frame).....	5-86
Manifold Layout — 23 Row Coulter Assembly Fittings and Hoses.....	5-88
Manifold Layout — 25 Row Coulter Assembly Fittings and Hoses.....	5-90
Controller Components.....	5-92

AT4615 Main Frame

Please visit www.unverferth.com/parts/ for the most current parts listing.

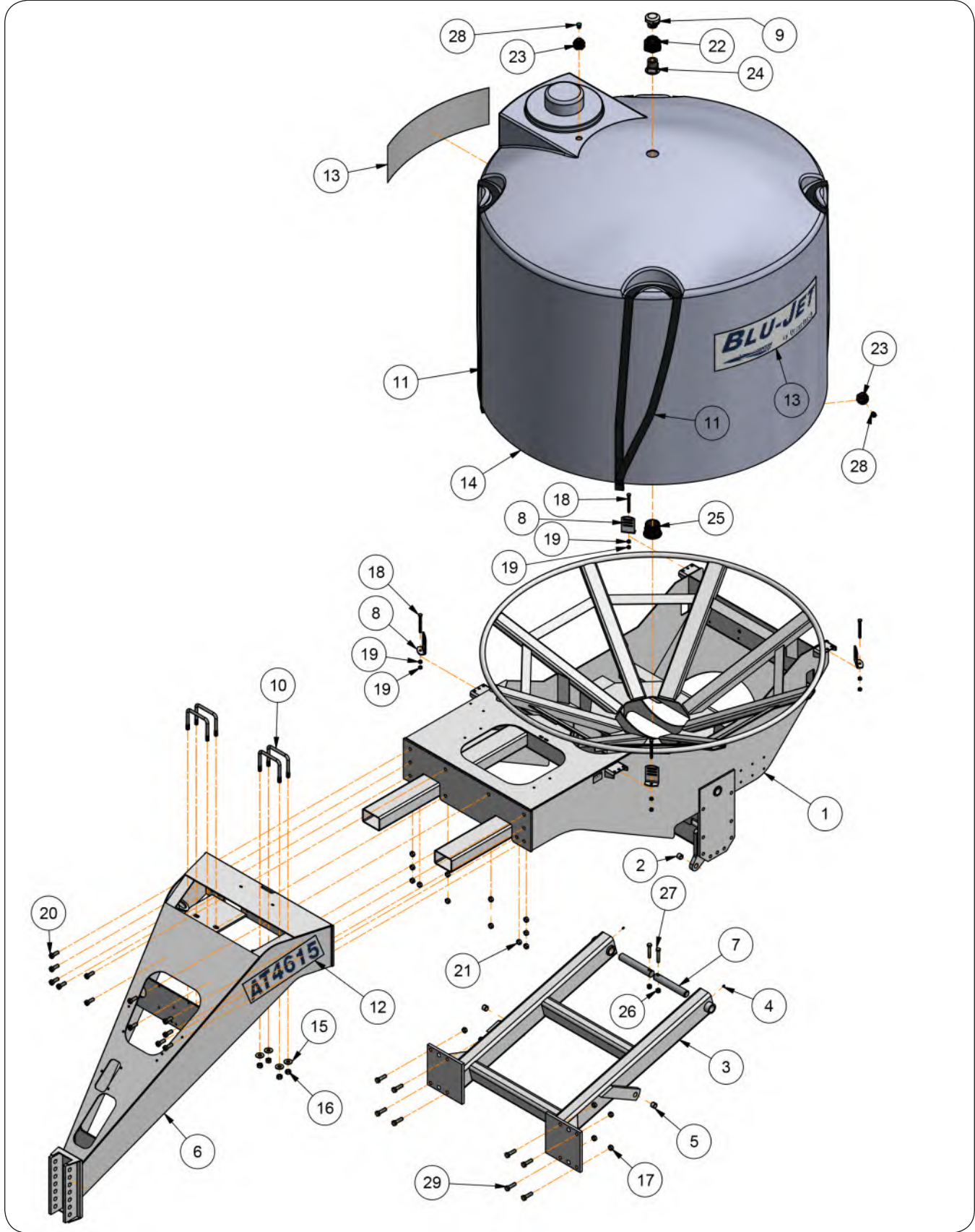

AT4615 — Parts

AT4615 Main Frame

Please visit www.unverferth.com/parts/ for the most current parts listing.

ITEM	PART NUMBER	DESCRIPTION	QTY	NOTES
	JAAM2844	Cart Assembly with Tank & Lift Arm		
1	JAM3648	Tank Main Frame Weldment, Cone Bottom Tank	1	
	91268	Split Tension Bushing, 1 1/4" OD x 1" ID x 1"	2	
3	JAM3638	Toolbar Lift Arm Weldment	1	Includes Items 4 & 5
	91160	Grease Zerk	2	
	91268	Split Tension Bushing, 1 1/4" OD x 1" ID x 1"	2	
6	JAM3687	Tongue Weldment	1	
7	JBM3496	Pin, 1 3/4" Dia. x 10 3/4"	2	
8	JAM4432	Tank Strap Adjustment Bracket	4	
9	JCP2042	Hooded Vent Cap 2" Male NPT w/304 SS Mesh Screen	1	
10	JBP3352	U-Bolt, 3/4"-10UNC x 5 11/16", 6 13/16" C/C G5	4	
11	TA500499	Strapping 2" (Breaking Strength 10,000 Lbs.)	48	
12	JAP2582	Decal, AT4615	2	
13	JAP2575	Decal, Blu-Jet "By Unverferth"	2	
14	JAP3209	Tank 1775 Gallon 30° Cone Bottom Includes Lid & Bottom Tank Fitting	1	
	JAP2476	Tank Lid, 10"	-	
15	9405-106	Flat Washer, 3/4" USS	8	
16	9394-016	Hex Nut, 3/4"-10UNC	8	
17	97025	Lock Nut/Top, 3/4"-10UNC	8	
18	95791	Capscrew, 1/2"-13UNC x 5" Full Threaded G5	4	
19	9394-010	Hex Nut, 1/2"-13UNC	8	
20	91299-145	Capscrew, 3/4"-10UNC x 2" G8	12	
21	97025	Lock Nut/Top, 3/4"-10UNC	12	
22	TA805428	Tank Fitting, 2" Double Threaded (3" Hole Required)	1	
23	900043	Tank Fitting, 1/2" NPT Poly Bulkhead w/Double Sided Threads & EPDM Gasket	3	
24	TA815074	Vent Cap 2" Fitting	1	
25	TA816050	Adapter Manifold Flange 3"x3" NPT Male	1	
26	9398-019	Elastic Lock Nut, 5/8"-11UNC	2	
27	9390-130	Capscrew, 5/8"-11UNC x 3 1/2" G5	2	
28	TA814750	Plug Poly, 1/2"-14 NPTF Male	3	
29	91299-147	Capscrew, 3/4"-10UNC x 2 1/2" G8	8	

Hitch, Transport Chain, Manual Holder and Jack Components

Please visit www.unverferth.com/parts/ for the most current parts listing.

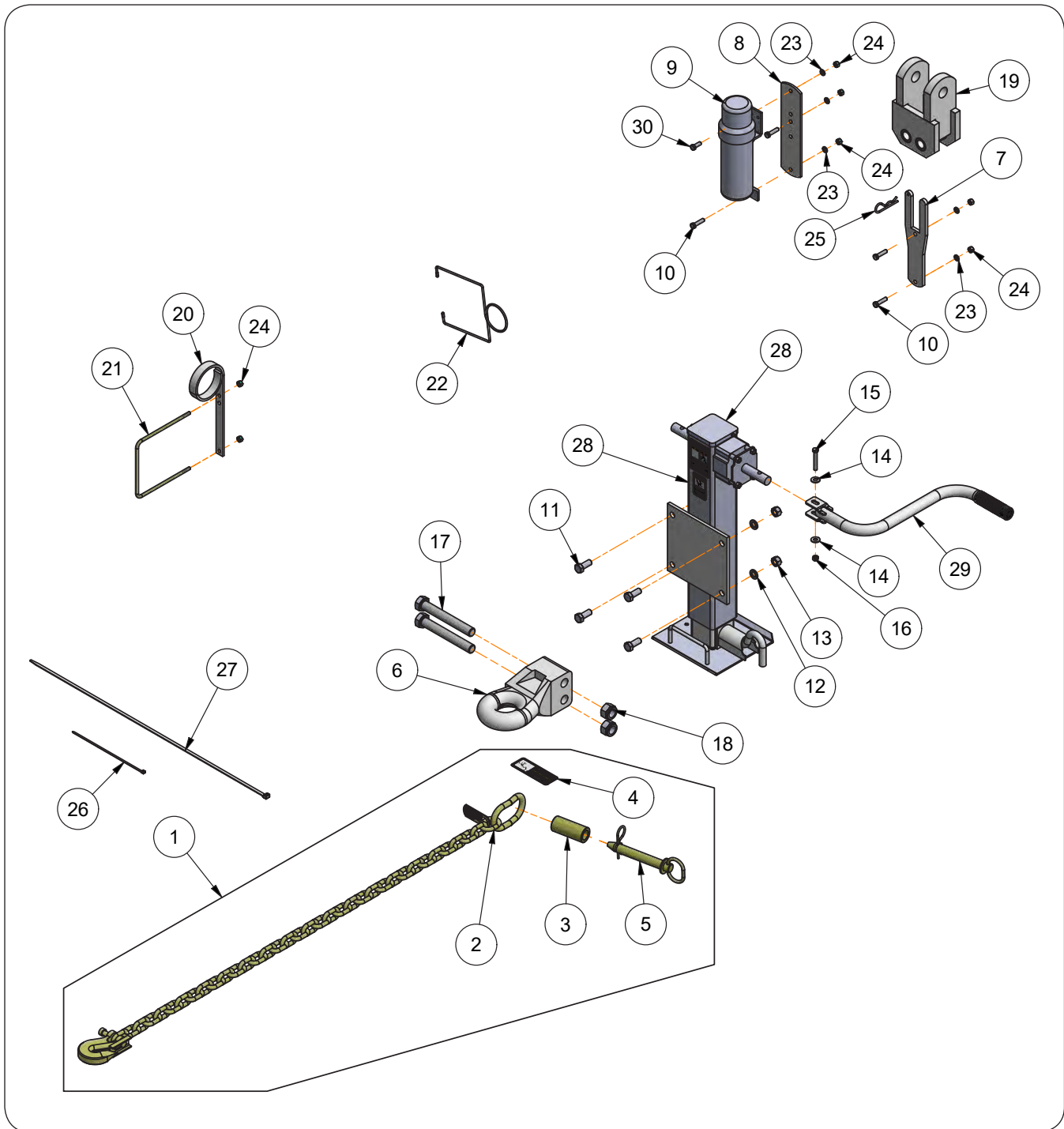

Hitch, Transport Chain, Manual Holder and Jack Components

Please visit www.unverferth.com/parts/ for the most current parts listing.

ITEM	PART NUMBER	DESCRIPTION	QTY	NOTES
1	JAAM2423	Transport Chain Kit	1	Includes Items 2-5
2	9003265	Transport Chain 30,400#	1	
3	JBM3498	Bushing	1	
4	97575	Decal, CAUTION (Transport Chain)	1	
5	93950	Hitch Pin, 1" Dia.x 8 w/.178" Dia. Hairpin	1	
6	JAP2864	Perfect Hitch CAT4 (SHOWN)	1	
	JAP3231	Ball Swivel Hitch CAT3		
	JAP3232	Ball Swivel Hitch CAT4		
7	JAM2145	Hitch Storage Bracket Mount	1	
8	JAM7640	Manual Holder Mounting Bracket	1	
9	900552	Manual Holder	1	
10	9390-057	Capscrew, 3/8"-16UNC x 1 1/2" G5	9	
11	9390-123	Capscrew, 5/8"-11UNC x 1 3/4" G5	4	
12	9404-029	Lock Washer, 5/8"	4	
13	9394-014	Hex Nut, 5/8"-11UNC	4	
14	9405-076	Flat Washer, 3/8" USS	2	
15	9390-061	Capscrew, 3/8"-16UNC x 2 1/2" G5	1	
16	902875	Lock Nut/Center, 3/8"-16UNC	1	
17	91299-198	Capscrew, 1"-8UNC x 7 1/2" G8	2	
18	9398-026	Elastic Lock Nut, 1"-8UNC	2	
19	JAM2144	Clevis Hitch Weldment	1	
20	JAM4015	Hose Retainer, Closed Loop	8	
21	JBP3335	U-Bolt, 3/8"-16UNC x 8", 7 7/16" C/C G5	8	
22	JAP2284-1	Hose Retainer w/Plastic Caps	12	
23	9404-021	Lock Washer, 3/8"	27	
24	9394-006	Hex Nut, 3/8"-16UNC	27	
25	JBP3500	Hairpin Cotter 0.172" Dia. x 3 1/2"	1	
26	9003735	Cable Tie, 11"	20	
27	94038	Cable Tie, 32"	6	
28	JAM3582	Jack 12,000# Weldment	1	
29	JAP3214	Crank Handle	1	
30	9390-055	Capscrew, 3/8"-16UNC x 1" G5	1	

Decals

Please visit www.unverferth.com/parts/ for the most current parts listing.

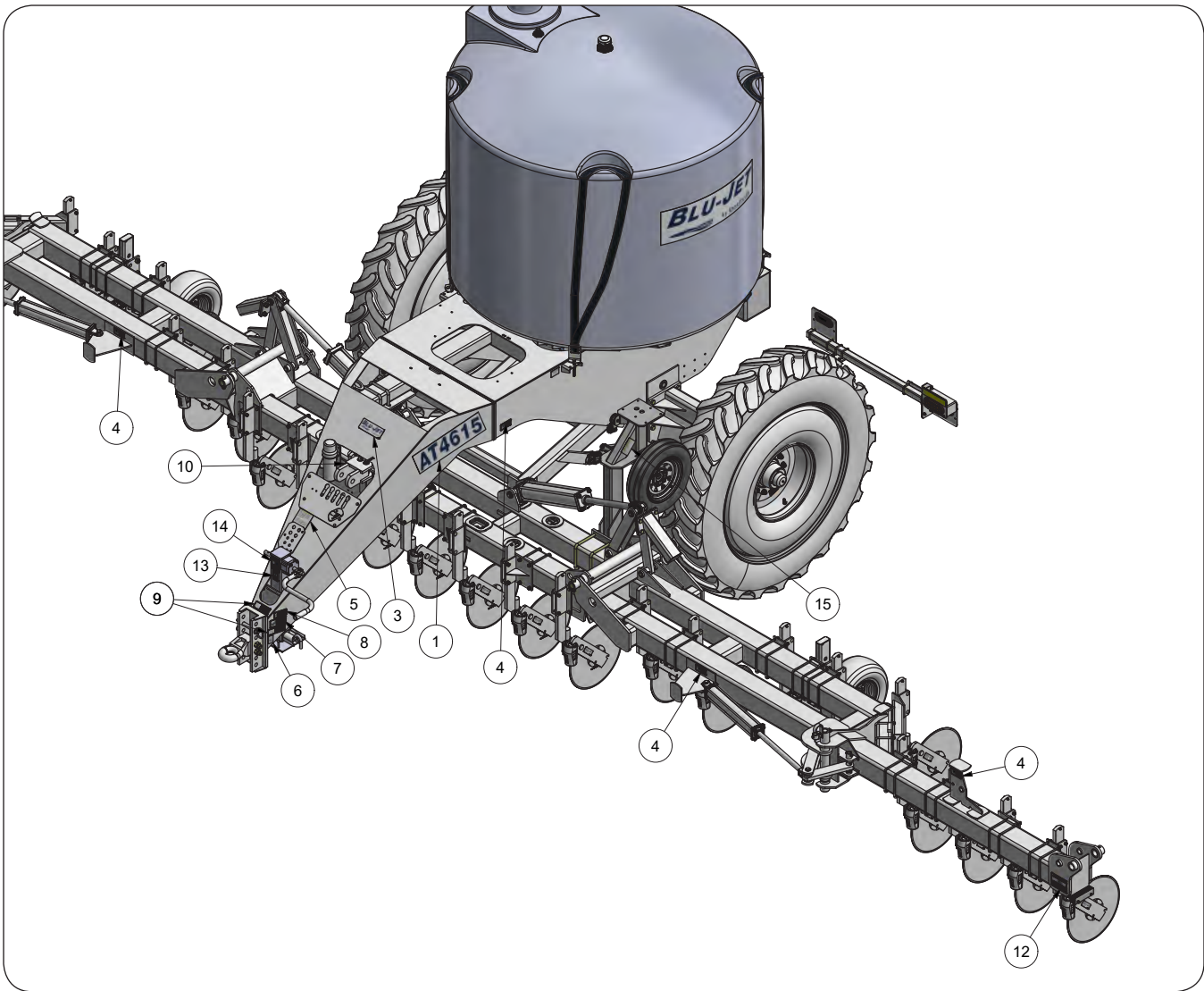

Decals

Please visit www.unverferth.com/parts/ for the most current parts listing.

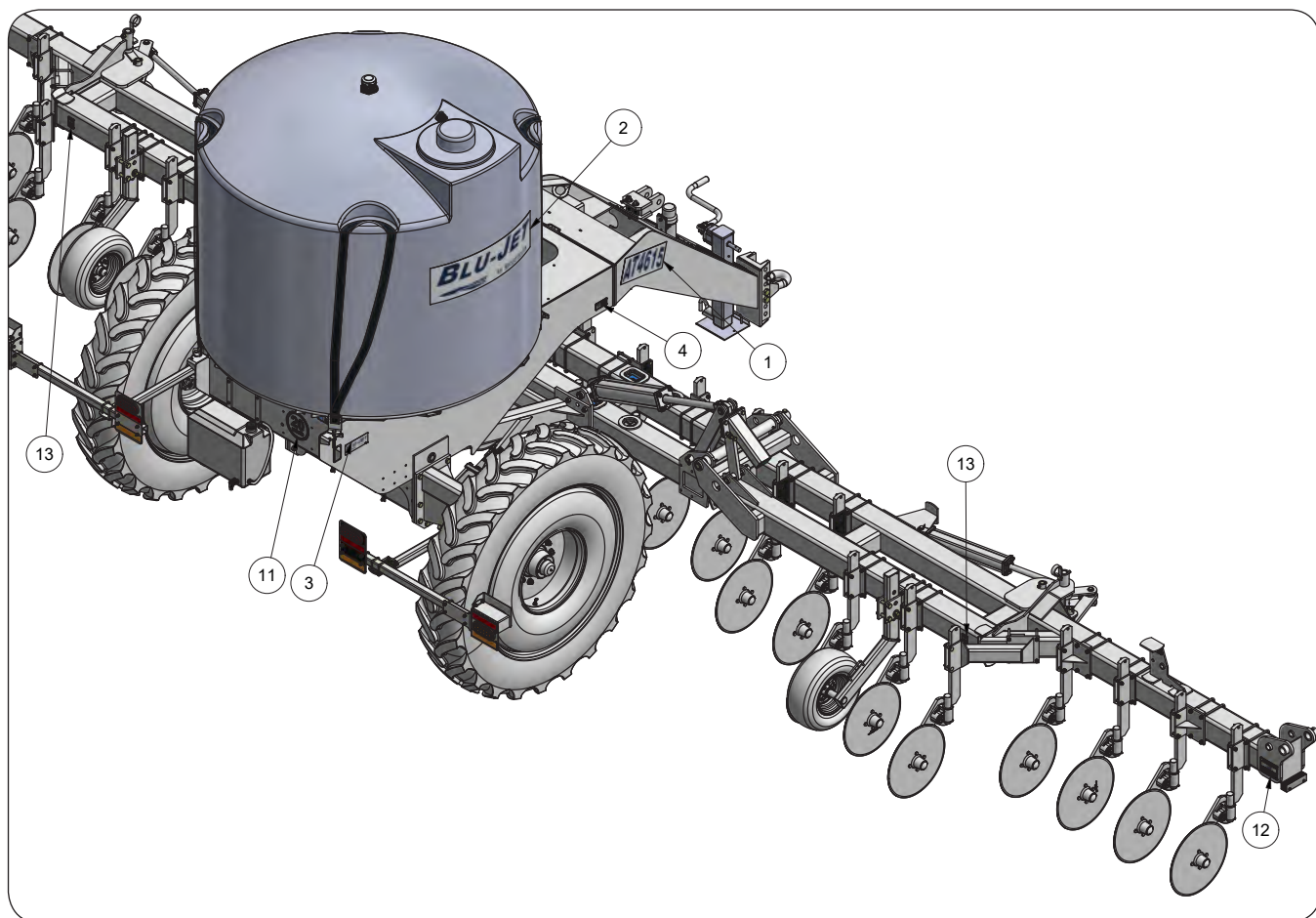

ITEM	PART NUMBER	DESCRIPTION	QTY
1	JAP2582	Decal, AT4615	2
2	JAP2575	Decal, Blu-Jet "By Unverferth"	2
3	JAP2215	Decal, BLU-JET By Unverferth	3
4	95839	Decal, WARNING (Pinch Point)	2
5	JAP2497	Decal, CAUTION (Primary Wing Fold Hydraulics Must Be In Float Position...)	1
6	91605	Decal, FEMA	1
7	95445	Decal, WARNING (High-Pressure Fluid...)	1
8	97961	Decal, WARNING (Read and Understand...)	1
9	97575	Decal, CAUTION (Transport Chain)	2
10	9008715	Front SIS Decal, 20MPH	1
	9008721	Front SIS Decal, 30KPH	1
11	9008714	Rear SIS Decal, 20MPH	1
	9008720	Rear SIS Decal, 30KPH	1
12	97337	Decal, WARNING (Folding or Unfolding Wings...)	6
13	97048	Decal, WARNING (Pinch Point)	3
14	9501197	Decal, WARNING "Gooseneck Jack"	1
15	JAP2472	Decal, CAUTION "Avoid Pump Damage"	1

Clean Water Tank Components

Please visit www.unverferth.com/parts/ for the most current parts listing.

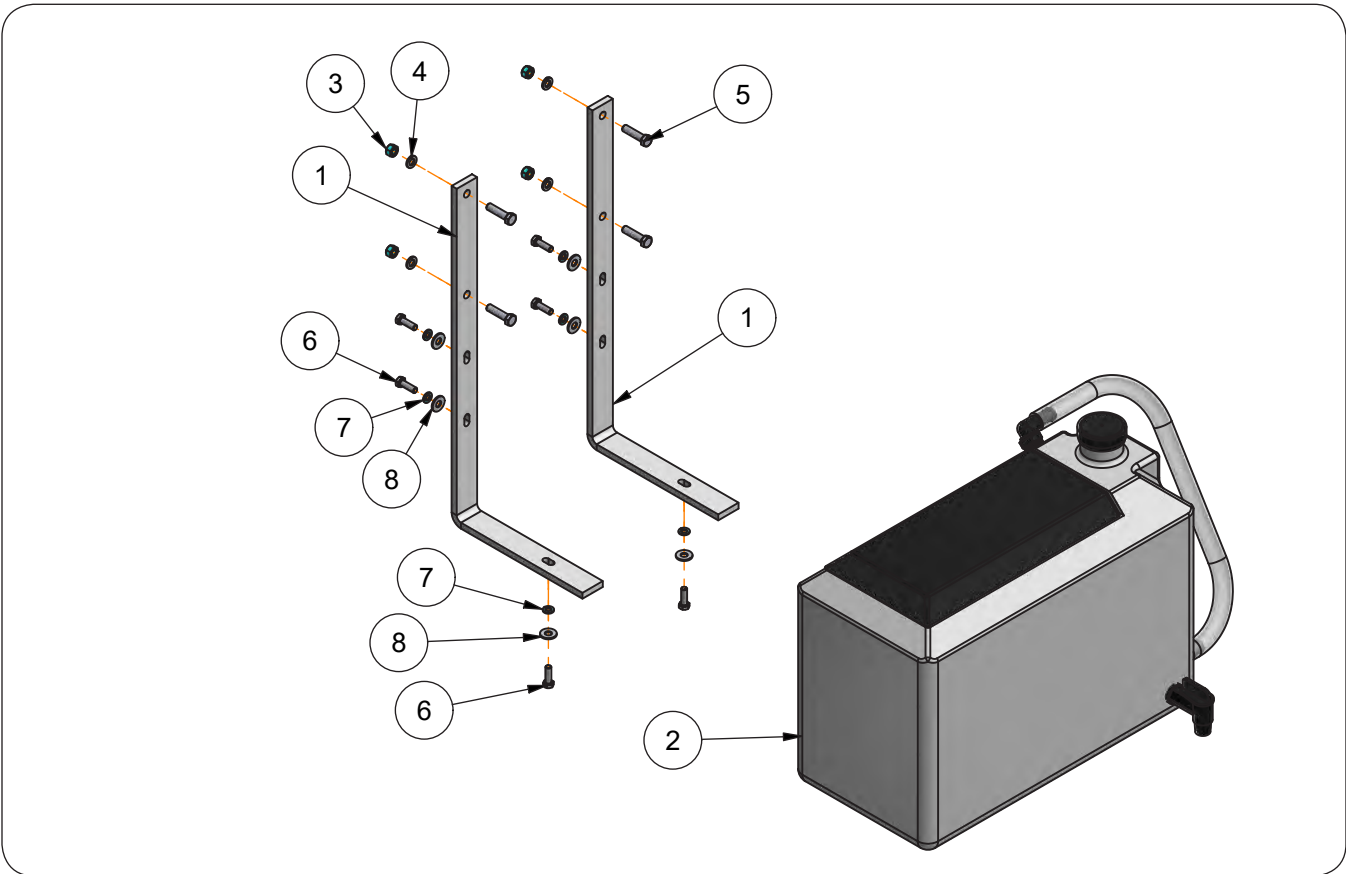

ITEM	PART NUMBER	DESCRIPTION	QTY	NOTES
1	JAM4421	Tank Mounting Bracket	2	
2	JAP2137	Clean Fresh Water Tank	1	
3	9394-006	Hex Nut, 3/8"-16UNC	4	
4	9404-021	Lock Washer, 3/8"	4	
5	9390-057	Capscrew, 3/8"-16UNC x 1 1/2" G5	4	
6	9390-030	Capscrew, 5/16"-18UNC x 1" G5	6	
7	9404-019	Lock Washer, 5/16"	6	
8	9405-070	Flat Washer, 5/16" USS	6	

Wheel/Axle, 120" Single, 380/90R46

Please visit www.unverferth.com/parts/ for the most current parts listing.

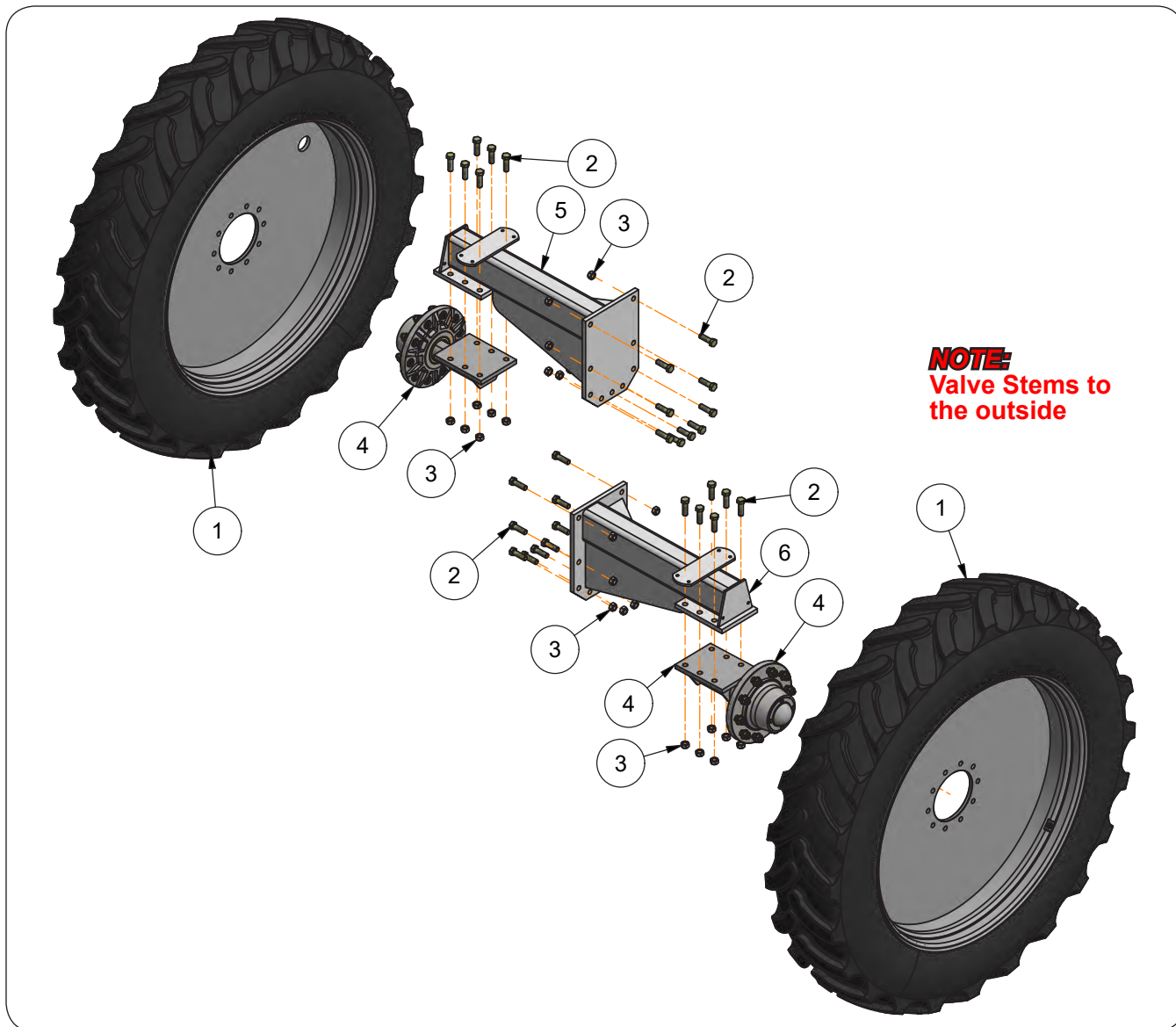

ITEM	PART NUMBER	DESCRIPTION	QTY	NOTES
	J44100115	Wheel & Axle Assembly -120" Single	1	Includes Items 1-6
1	111277SM	Wheel & Tire Assembly TLVF380/90R46 R-1 (Silver Mist)	2	
	93300	Valve Stem	1	
	9503229	Tire, TLVF380/90R46MT 173D	1	
	111142SM	13x46 Plate Wheel	1	
2	91299-147	Capscrew, 3/4"-10UNC x 2 1/2" G8	30	
3	97025	Lock Nut/Top, 3/4"-10UNC	30	
4	JAAM2791	Hub & Spindle Assembly	2	
5	JAM3655	Axle LH Weldment - 120" Single	1	
6	JAM3656	Axle RH Weldment - 120" Single	1	

Hub and Spindle Components

Please visit www.unverferth.com/parts/ for the most current parts listing.

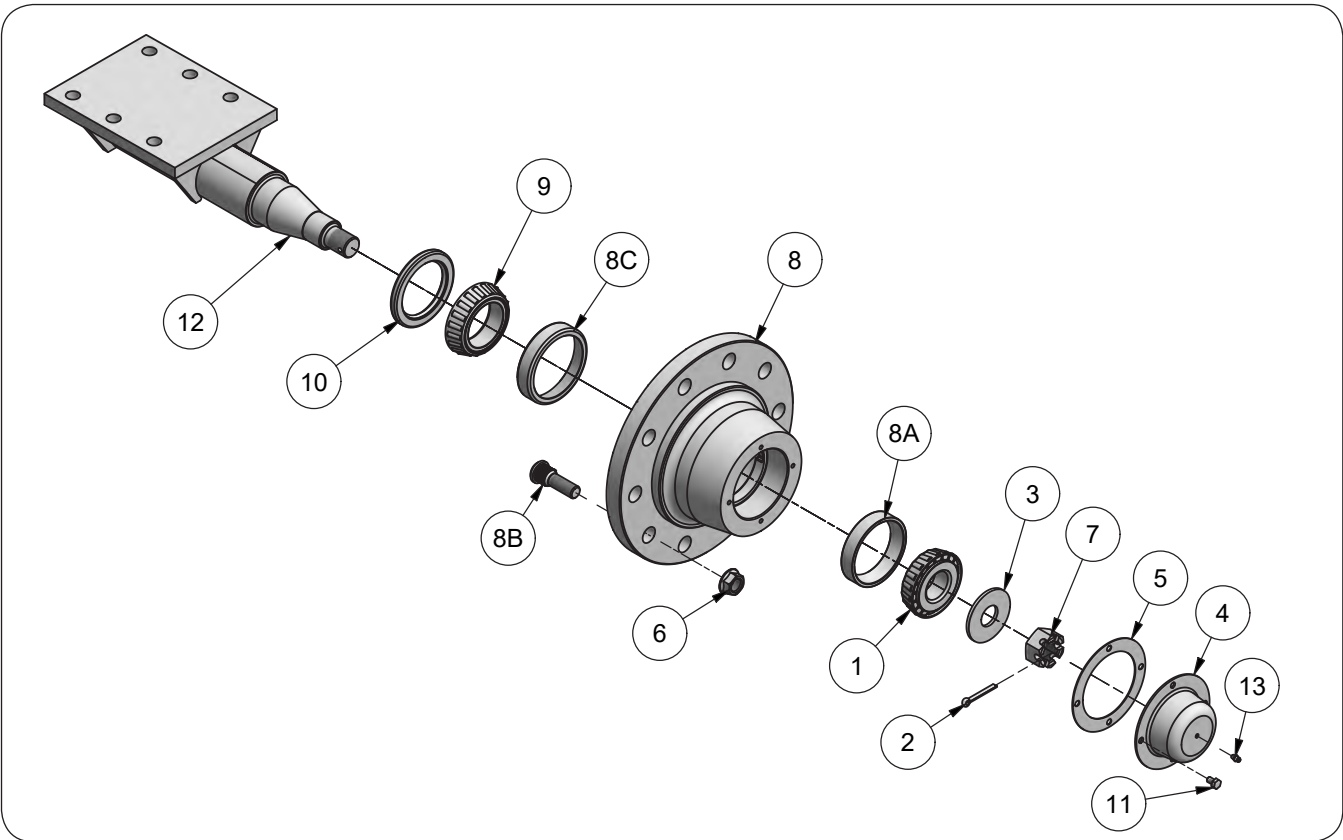

Hub and Spindle Components

Please visit www.unverferth.com/parts/ for the most current parts listing.

ITEM	PART NUMBER	DESCRIPTION	QTY	NOTES
1	92463	Bearing Cone #460, 1.750" Bore	1	
2	9391-059	Cotter Pin 1/4" Dia. x 2"	1	
3	92471	Spindle Washer 3 1/4" OD x 1.300" ID x 3/16"	1	
4	281881B	Hub Cap - 4 Bolt w/Grease Port	1	
5	284229	Gasket 5.6875" OD x 4.125" ID	1	
6	92458	Wheel Nut, 3/4"-16UNF G8	10	
7	9002721	Slotted Nut 1 1/4"-12UNF	1	
8	44542	Hub 10 Bolt Assembly	1	Includes Items 8A, 8B, 8C
8A	92461	Bearing Cup #453A, 4 1/4" OD	1	
8B	9004943	Stud Bolt 3/4"-16UNF x 2.75" (Drive-In Wheel Bolt)	10	
8C	92475	Bearing Cup #33462, 4.625" OD	1	
9	92546	Inner Bearing Cone #33275, 2.750" Bore	1	
10	92829	Seal 3 3/8" ID	1	
11	9390-026	Capscrew, 5/16"-18UNC x 1/2" G5	4	
12	JEM7279	Spindle & Mounting Plate Weldment	1	
13	91160	Grease Zerk	1	

Double Tube Toolbar - Center Section & Gull Wing Components

Please visit www.unverferth.com/parts/ for the most current parts listing.

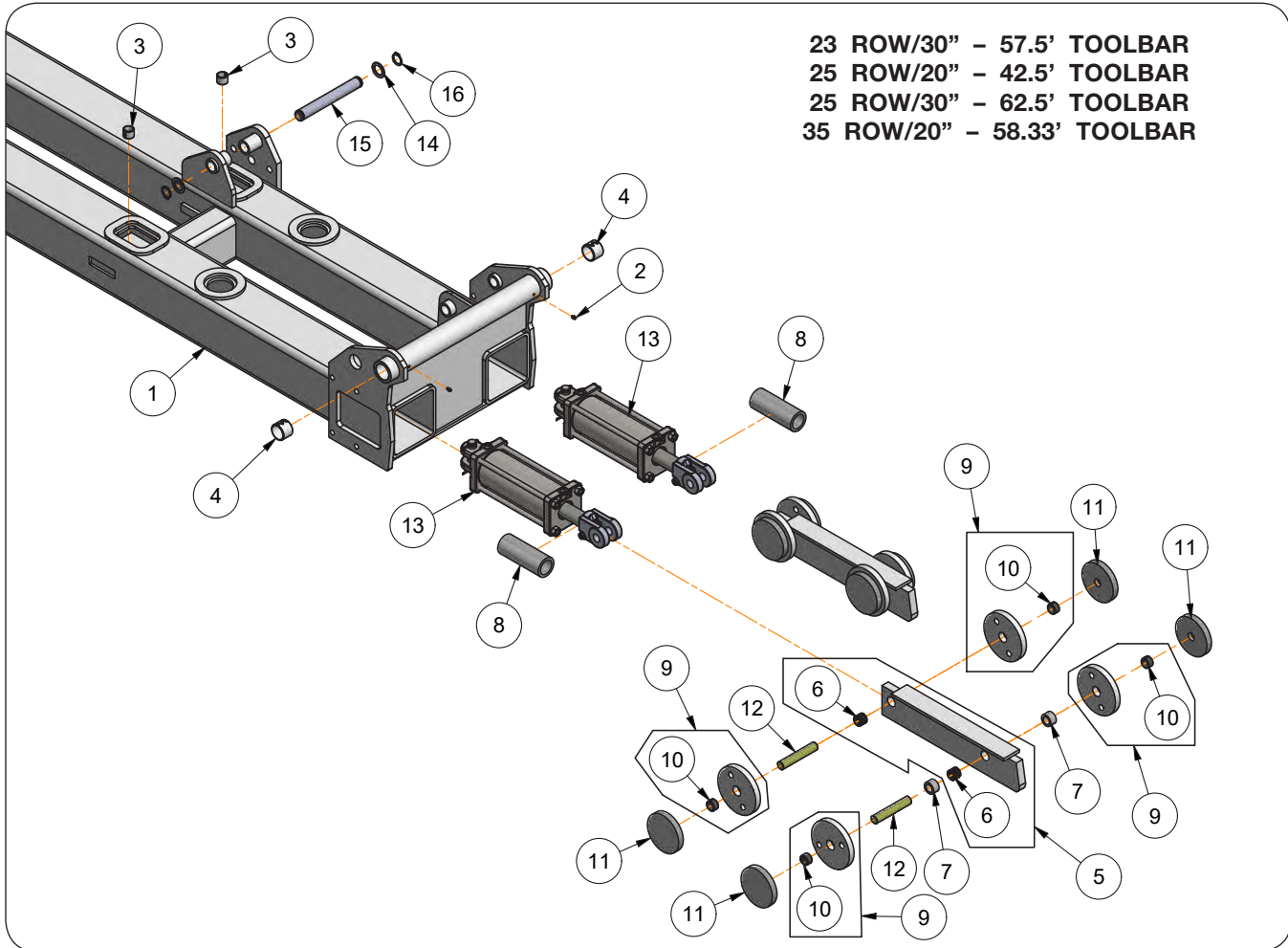

ITEM	PART NUMBER	DESCRIPTION	QTY	NOTES
	JAAM2920	Gull Wing Center Section Frame Assembly		Includes Items 1-13
1	JAM3686	Center Toolbar Frame Weldment	1	Includes Items 2-4
2	91160	Grease Zerk, 1/4"-28	4	
3	91268	Split Tension Bushing, 1 1/4" OD x 1" ID x 1"	4	
4	JBP3538	Split Tension Bushing, 2" OD x 1 3/4" ID x 1 1/2"	4	
5	JAM3539	Gull Wing Linkage Weldment	4	Includes Item 6
6	91268	Split Tension Bushing 1 1/4" OD x 1" ID x 1"	2	
7	JAM3540	Bushing, 1 1/2" OD x 1.020" ID x 7/8"	8	
8	JAM3541	Bushing, 2 1/2" OD x 1.812" ID x 6 1/2"	4	
9	JAM4410	Roller Assembly with Bushing	16	Includes Item 10
10	95122	Split Tension Bushing, 1 1/4" OD x 1" ID x 3/4"	1	
11	JAP2385	Roller, 5" OD x 1.015" ID	16	
12	JBM3492	Pin, 1" Dia. x 5 1/2"	8	
13	JDP4490	Cylinder, 4" x 8" 3000 PSI, with Base End Pin	4	
	95407	Seal Kit		
14	JBP3192	Machinery Bushing, 1 7/8" OD x 1/4" ID	4	
15	JBM3544	Pin, 1 1/4" Dia. x 9.78"	2	
16	JAP2711	Snap Ring 1 1/4", External Heavy-Duty	4	

Single Tube Toolbar - Center Section & Gull Wing Components

Please visit www.unverferth.com/parts/ for the most current parts listing.

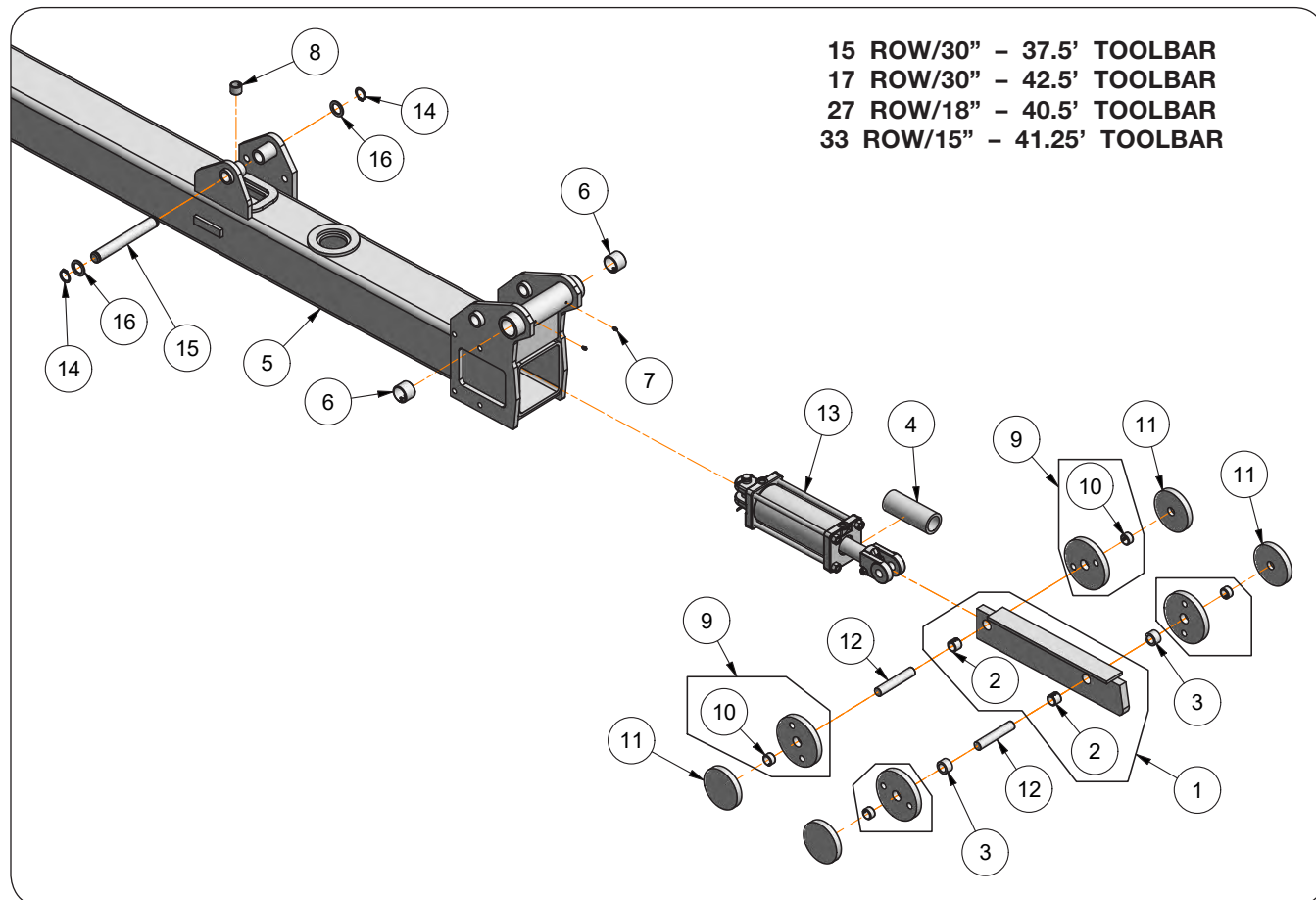

15 ROW/30" - 37.5' TOOLBAR
 17 ROW/30" - 42.5' TOOLBAR
 27 ROW/18" - 40.5' TOOLBAR
 33 ROW/15" - 41.25' TOOLBAR

ITEM	PART NUMBER	DESCRIPTION	QTY	NOTES
	JAAM2916	Gull Wing Center Section Frame Assembly		Includes Items 1-13
1	JAM3539	Gull Wing Linkage Weldment	2	Includes Item 2
2	91268	Split Tension Bushing 1 1/4" OD x 1" ID x 1"	2	
3	JAM3540	Bushing, 1 1/2" OD x 1.020" ID x 7/8"	4	
4	JAM3541	Bushing, 2 1/2" OD x 1.812" ID x 6 1/2"	2	
5	JAM3584	Center Gull Wing Frame Weldment	1	Includes Items 6-8
6	JBP3538	Split Tension Bushing, 2" OD x 1 3/4" ID x 1 1/2"	4	
7	91160	Grease Zerk, 1/4"-28	4	
8	91268	Split Tension Bushing, 1 1/4" OD x 1" ID x 1"	2	
9	JAM4410	Roller Assembly with Bushing	8	Includes Item 10
10	95122	Split Tension Bushing, 1 1/4" OD x 1" ID x 3/4"	1	
11	JAP2385	Roller, 5" OD x 1.015" ID	8	
12	JBM3492	Pin, 1" Dia. x 5 1/2"	44	
13	JDP4490	Cylinder, 4" x 8" 3000 PSI, with Base End Pin	2	
	95407	Seal Kit		
14	JAP2711	Snap Ring 1 1/4", External Heavy-Duty	4	
15	JBM3544	Pin, 1 1/4" Dia. x 9.78"	2	
16	JBP3192	Machinery Bushing, 1 7/8" OD x 1/4" ID	4	

Primary Wing Components (Double Tube Toolbar)

Please visit www.unverferth.com/parts/ for the most current parts listing.

- 23 ROW/30" - 57.5' TOOLBAR
- 25 ROW/20" - 42.5' TOOLBAR
- 25 ROW/30" - 62.5' TOOLBAR
- 35 ROW/20" - 58.33' TOOLBAR

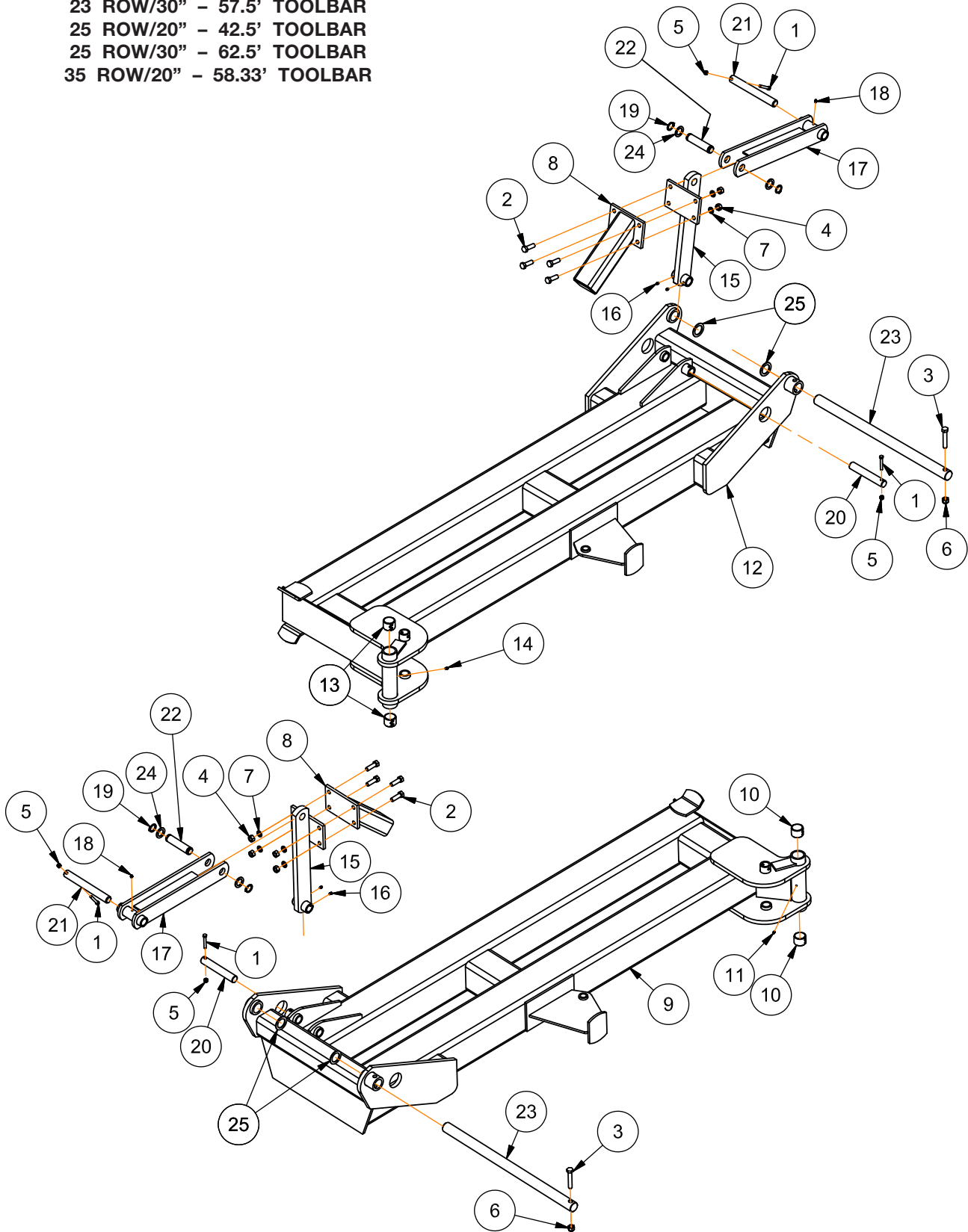

Primary Wing Components (Double Tube Toolbar)

Please visit www.unverferth.com/parts/ for the most current parts listing.

ITEM	PART NUMBER	DESCRIPTION	QTY	NOTES
1	9390-061	Capscrew, 3/8"-16UNC x 2 1/2" G5	4	
2	9390-124	Capscrew, 5/8"-11UNC x 2" G5	8	
3	9390-130	Capscrew, 5/8"-11UNC x 3 1/2" G5	2	
4	9394-014	Hex Nut, 5/8"-11UNC	8	
5	9398-012	Elastic Lock Nut, 3/8"-16UNC	4	
6	9398-019	Elastic Lock Nut, 5/8"-11UNC	2	
7	9404-029	Lock Washer, 5/8"	8	
8	JAM3542	Wing Stop Weldment	2	
9	JAM3650	Primary Wing LH Weldment	1	Includes Items 10 & 11
10	JBP3538	Split Tension Bushing, 2" OD x 1 3/4" ID x 1 1/2"	2	
11	91160	Grease Zerk	1	
12	JAM3651	Primary Wing RH Weldment	1	Includes Items 13 & 14
13	JBP3538	Split Tension Bushing, 2" OD x 1 3/4" ID x 1 1/2"	2	
14	91160	Grease Zerk	1	
15	JAM3653	Wing Fold Linkage 19" Weldment	2	Includes Item 16
16	91160	Grease Zerk	2	
17	JAM3654	Wing Fold Linkage Weldment	2	Includes Item 18
18	91160	Grease Zerk	1	
19	JAP2711	Snap Ring 1 1/4", External Heavy-Duty	4	
20	JBM3465	Pin, 1 1/4" Dia. x 7 3/4"	2	
21	JBM3486	Pin, 1 1/4" Dia. x 10 7/16"	2	
22	JBM3548	Pin, 1 1/4" Dia. x 5.53"	2	
23	JBM3599	Pin, 1 3/4" Dia. x 31 1/2"	2	
24	JBP3192	Machinery Bushing, 1 7/8" OD x 1/4" ID	4	
25	JBP3205	Machinery Bushing, 2 1/2" OD x 1 3/4" ID	4	

Primary Wing Components (Single Tube Toolbar)

Please visit www.unverferth.com/parts/ for the most current parts listing.

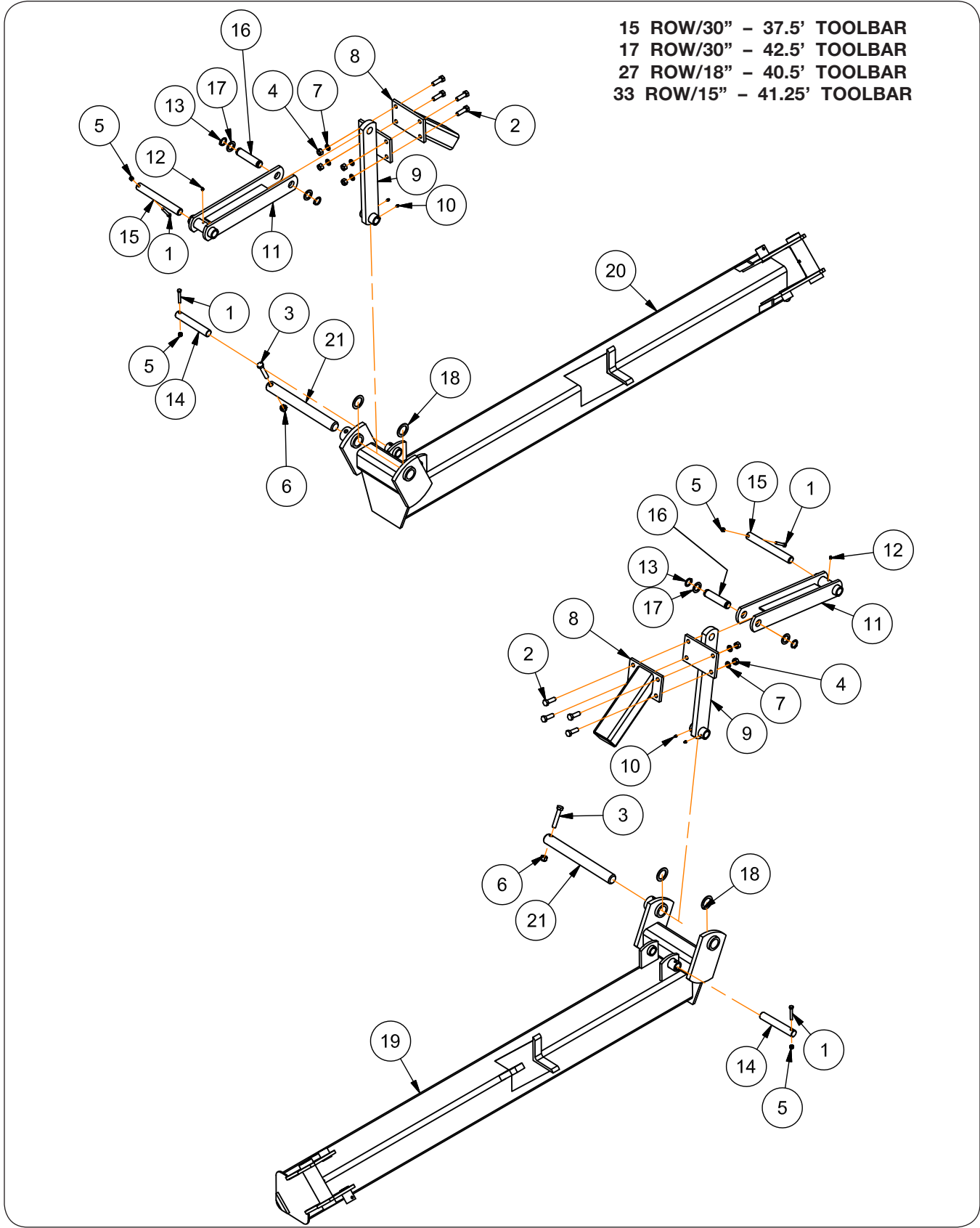

Primary Wing Components (Single Tube Toolbar)

Please visit www.unverferth.com/parts/ for the most current parts listing.

ITEM	PART NUMBER	DESCRIPTION	QTY	NOTES
1	9390-061	Capscrew, 3/8"-16UNC x 2 1/2" G5	4	
2	9390-124	Capscrew, 5/8"-11UNC x 2" G5	8	
3	9390-130	Capscrew, 5/8"-11UNC x 3 1/2" G5	2	
4	9394-014	Hex Nut, 5/8"-11UNC	8	
5	9398-012	Elastic Lock Nut, 3/8"-16UNC	4	
6	9398-019	Elastic Lock Nut, 5/8"-11UNC	2	
7	9404-029	Lock Washer, 5/8"	8	
8	JAM3542	Wing Stop Weldment	2	
9	JAM3653	Wing Fold Linkage 19" Weldment	2	Includes Item 10
10	91160	Grease Zerk	2	
11	JAM3654	Wing Fold Linkage Weldment	2	Includes Item 12
12	91160	Grease Zerk	1	
13	JAP2711	Snap Ring 1 1/4", External Heavy-Duty	4	
14	JBM3465	Pin, 1 1/4" Dia. x 7 3/4"	2	
15	JBM3486	Pin, 1 1/4" Dia. x 10 7/16"	2	
16	JBM3548	Pin, 1 1/4" Dia. x 5.53"	2	
17	JBP3192	Machinery Bushing, 1 7/8" OD x 1/4" ID	4	
18	JBP3205	Machinery Bushing, 2 1/2" OD x 1 3/4" ID	4	
19	JAM3534	Primary Wing RH Weldment	1	
20	JAM3535	Primary Wing LH Weldment	1	
21	JBM3664	Pin, 1 3/4" Dia. x 16 9/16"	2	

Secondary Wing Components (Double Tube Toolbar)

Please visit www.unverferth.com/parts/ for the most current parts listing.

23 ROW/30" - 57.5' TOOLBAR
25 ROW/20" - 42.5' TOOLBAR
25 ROW/30" - 62.5' TOOLBAR
35 ROW/20" - 58.33' TOOLBAR

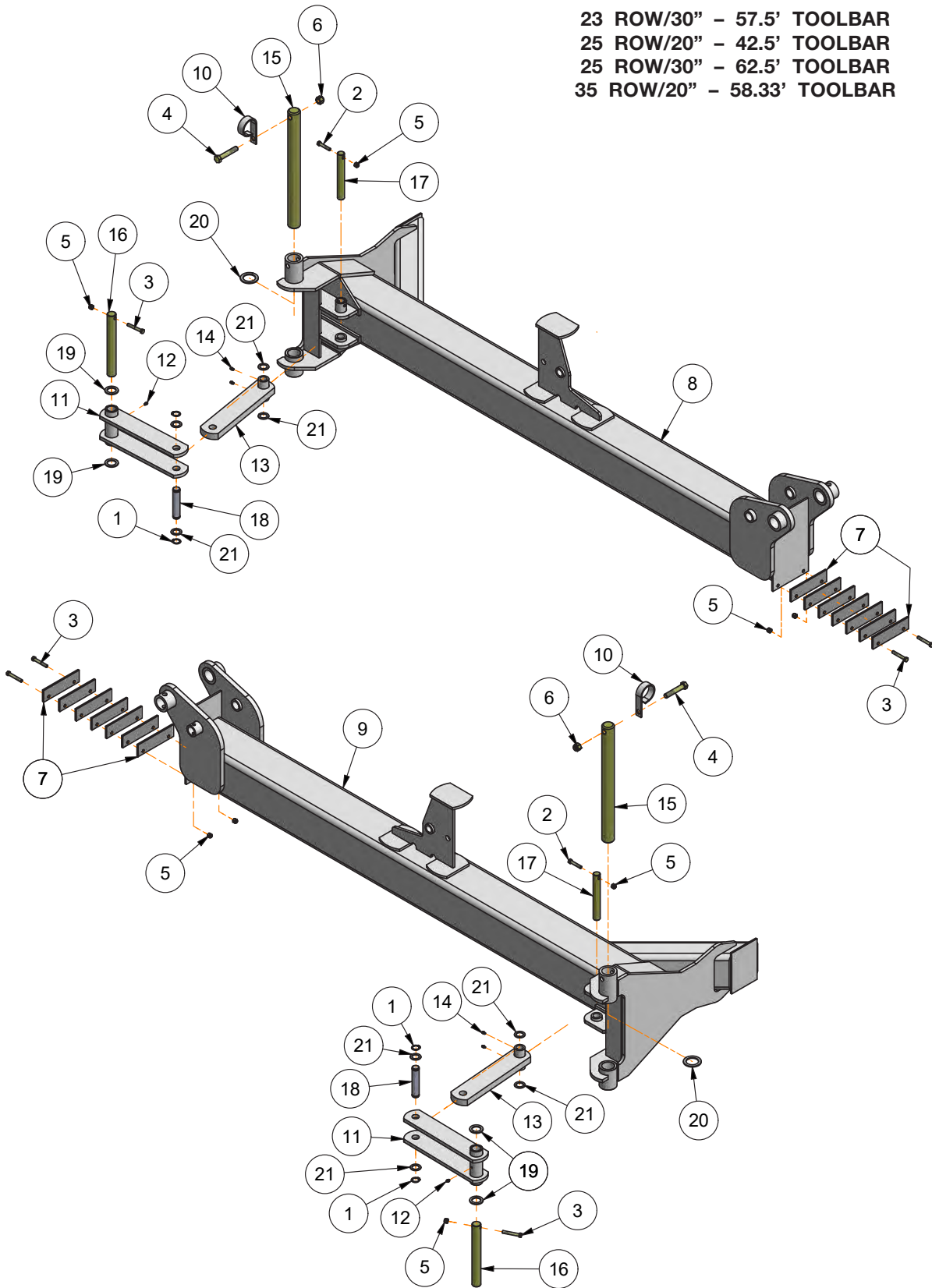

Secondary Wing Components (Double Tube Toolbar)

Please visit www.unverferth.com/parts/ for the most current parts listing.

ITEM	PART NUMBER	DESCRIPTION	QTY	NOTES
1	91192	Retaining Ring 1"	4	
2	9390-059	Capscrew, 3/8"-16UNC x 2" G5	2	
3	9390-061	Capscrew, 3/8"-16UNC x 2 1/2" G5	6	
4	9390-130	Capscrew, 5/8"-11UNC x 3 1/2" G5	2	
5	9398-012	Elastic Lock Nut, 3/8"-16UNC	8	
6	9398-019	Elastic Lock Nut, 5/8"-11UNC	2	
7	JAM3625	Spacer/Bar 2" x 7"	14	
8	JAM3646	Secondary Wing LH Weldment	1	
9	JAM3647	Secondary Wing RH Weldment	1	
10	JAM4442	Hose Retainer Closed Loop	2	
11	JAM4515	Gull Wing Linkage Weldment, Cylinder #1	2	Includes Item 12
12	91160	Grease Zerk	1	
13	JAM4516	Gull Wing Linkage Weldment, Cylinder #2	2	Includes Item 14
14	91160	Grease Zerk	2	
15	JBM3461	Pin, 1 3/4" Dia. x 19 3/4"	2	
16	JBM3486	Pin, 1 1/4" Dia. x 10 7/16"	2	
17	JBM3487	Pin, 1" Dia. x 7 3/4"	2	
18	JBM3543	Pin, 1" Dia. x 4.91"	2	
19	JBP3192	Machinery Bushing, 1 7/8" OD x 1/4" ID	4	
20	JBP3205	Machinery Bushing, 2 1/2" OD x 1 3/4" ID	2	
21	JBP3215	Machinery Bushing, 1 1/2" OD x 1" ID	8	

Secondary Wing Components (Single Tube Toolbar)

Please visit www.unverferth.com/parts/ for the most current parts listing.

- 15 ROW/30" - 37.5' TOOLBAR
- 17 ROW/30" - 42.5' TOOLBAR
- 27 ROW/18" - 40.5' TOOLBAR
- 33 ROW/15" - 41.25' TOOLBAR

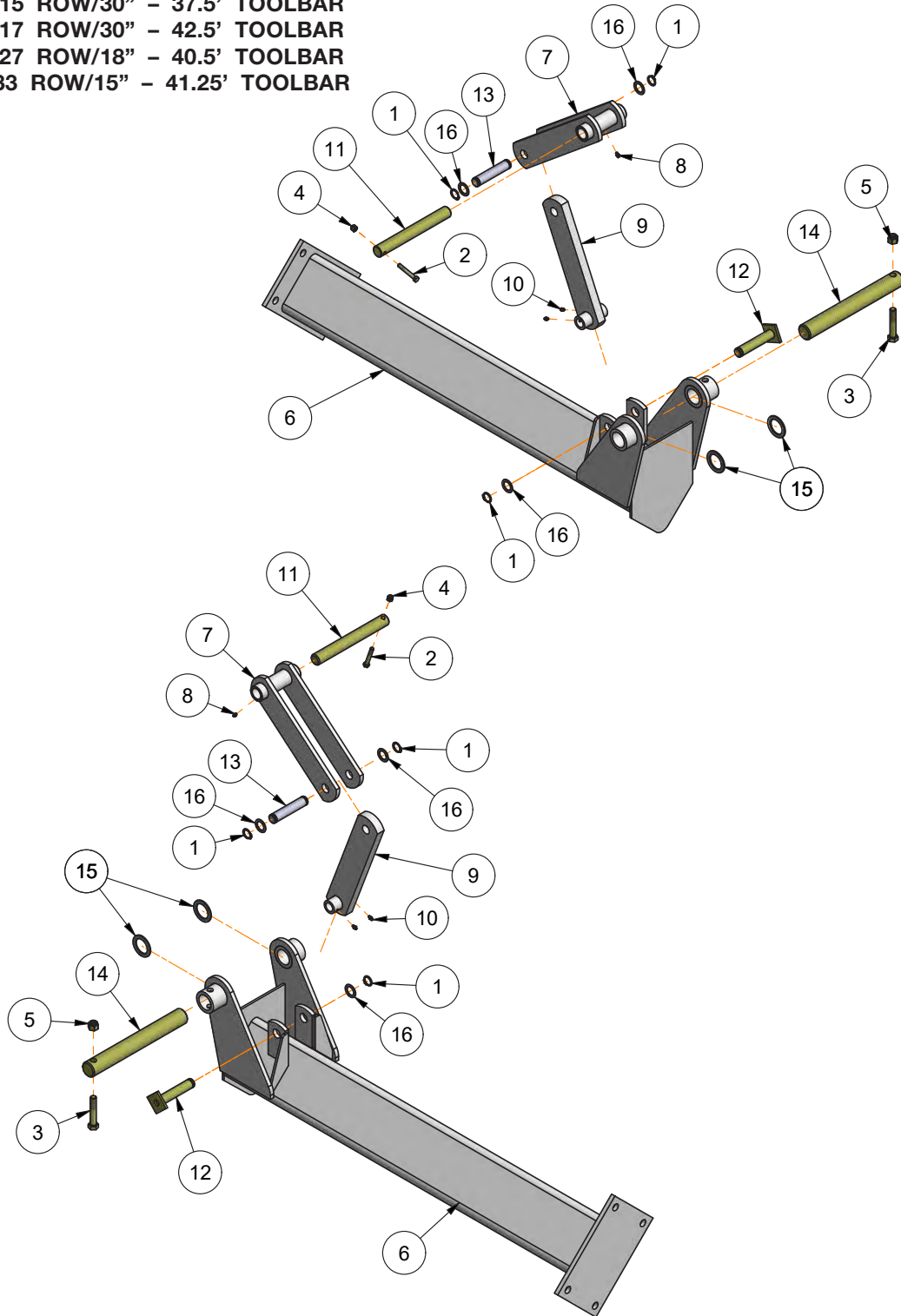

AT4615 — Parts

Secondary Wing Components (Single Tube Toolbar)

Please visit www.unverferth.com/parts/ for the most current parts listing.

ITEM	PART NUMBER	DESCRIPTION	QTY	NOTES
1	91192	Retaining Ring 1"	6	
2	9390-061	Capscrew, 3/8"-16UNC x 2 1/2" G5	2	
3	9390-130	Capscrew, 5/8"-11UNC x 3 1/2" G5	2	
4	9398-012	Elastic Lock Nut, 3/8"-16UNC	2	
5	9398-019	Elastic Lock Nut, 5/8"-11UNC	2	
6	JAM3532	Secondary Wing Weldment	2	
7	JAM4515	Gull Wing Linkage Weldment, Cylinder #1	2	Includes Item 8
8	91160	Grease Zerk	1	
9	JAM4516	Gull Wing Linkage Weldment, Cylinder #2	2	Includes Item 10
10	91160	Grease Zerk	2	
11	JBM3486	Pin, 1 1/4" Dia. x 10 7/16"	2	
12	JBM3542	Pin, 1" Dia. x 4 5/8"	2	
13	JBM3543	Pin, 1" Dia. x 4.91"	2	
14	JBM3570	Pin, 1 3/4" Dia. x 14"	2	
15	JBP3205	Machinery Bushing, 2 1/2" OD x 1 3/4" ID	4	
16	JBP3215	Machinery Bushing, 1 1/2" OD x 1" ID	6	

AT4615 — Parts

Third Wing Components (Double Tube Toolbar)

Please visit www.unverferth.com/parts/ for the most current parts listing.

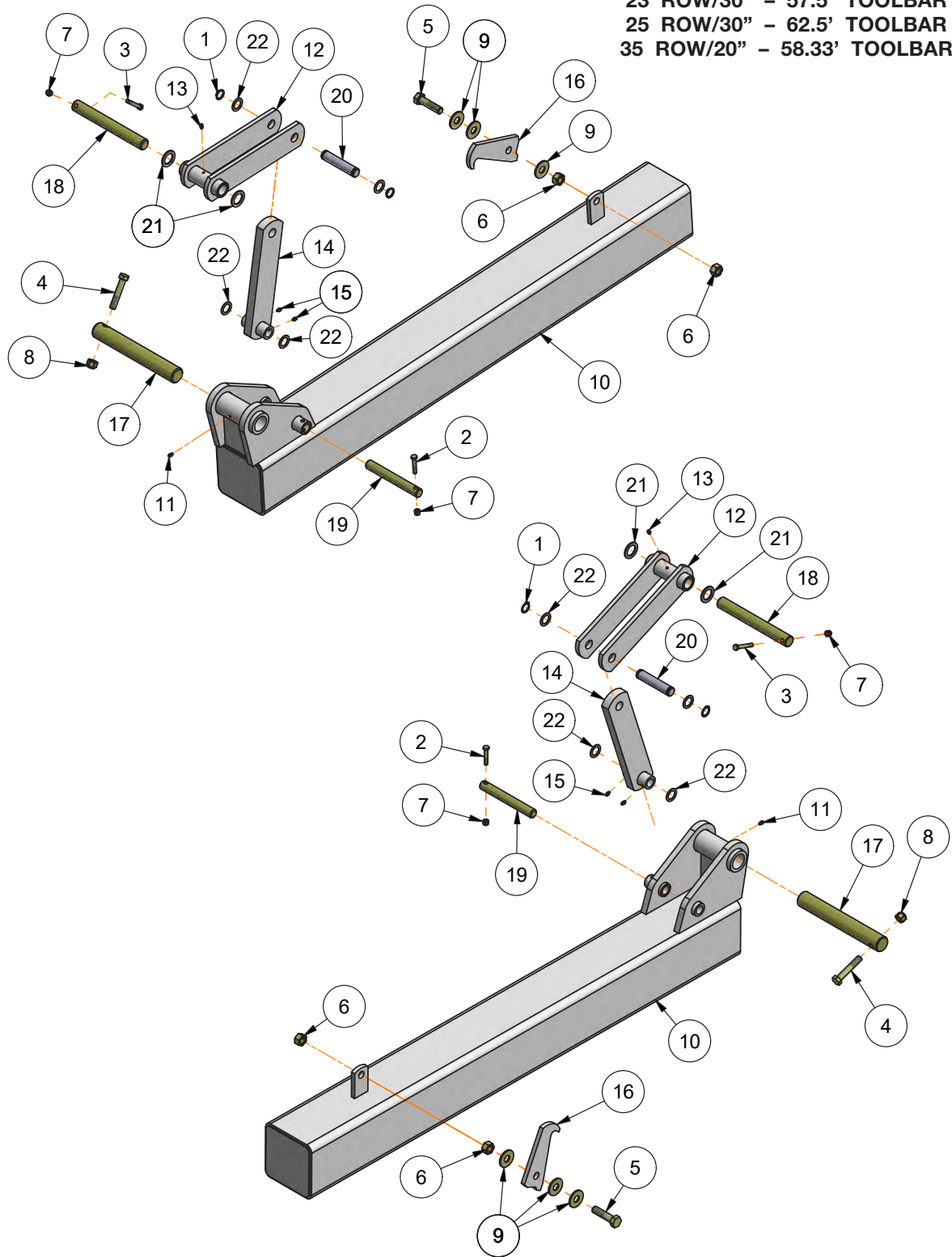

Third Wing Components (Double Tube Toolbar)

Please visit www.unverferth.com/parts/ for the most current parts listing.

ITEM	PART NUMBER	DESCRIPTION	QTY	NOTES
1	91192	Retaining Ring 1"	4	
2	9390-059	Capscrew, 3/8"-16UNC x 2" G5	2	
3	9390-061	Capscrew, 3/8"-16UNC x 2 1/2" G5	2	
4	9390-130	Capscrew, 5/8"-11UNC x 3 1/2" G5	2	
5	9390-149	Capscrew, 3/4"-10UNC x 3" G5	4	
6	9394-016	Hex Nut, 3/4"-10UNC	8	
7	9398-012	Elastic Lock Nut, 3/8"-16UNC	4	
8	9398-019	Elastic Lock Nut, 5/8"-11UNC	2	
9	9405-106	Flat Washer, 3/4" USS	6	
10	JAM3600	Third Wing Weldment	2	Includes Item 11
11	91160	Grease Zerk	2	
12	JAM3601	Wing Fold Linkage Weldment, Double	2	Includes Item 13
13	91160	Grease Zerk	2	
14	JAM3602	Wing Fold Linkage Weldment, Single	2	Includes Item 15
15	91160	Grease Zerk	4	
16	JAM4417	Wing Latch	2	
17	JBM3485	Pin, 1 3/4" Dia. x 12 1/8"	2	
18	JBM3486	Pin, 1 1/4" Dia. x 10 7/16"	2	
19	JBM3487	Pin, 1" Dia. x 7 3/4"	2	
20	JBM3543	Pin, 1" Dia. x 4.91"	2	
21	JBP3192	Machinery Bushing, 1 7/8" OD x 1/4" ID	4	
22	JBP3215	Machinery Bushing, 1 1/2" OD x 1" ID	6	

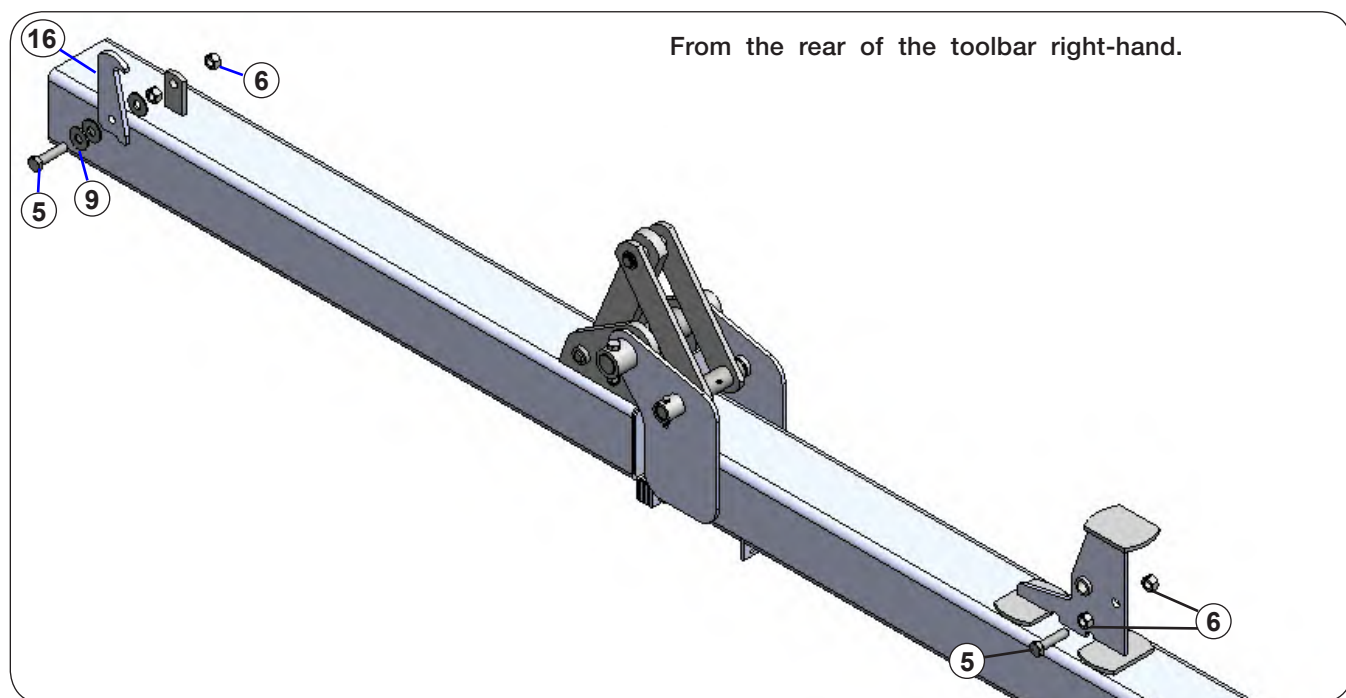

AT4615 — Parts

Wing Extension Components (Single Tube Toolbar)

Please visit www.unverferth.com/parts/ for the most current parts listing.

17 ROW/30" - 42.5' TOOLBAR
 27 ROW/18" - 40.5' TOOLBAR
 33 ROW/15" - 41.25' TOOLBAR

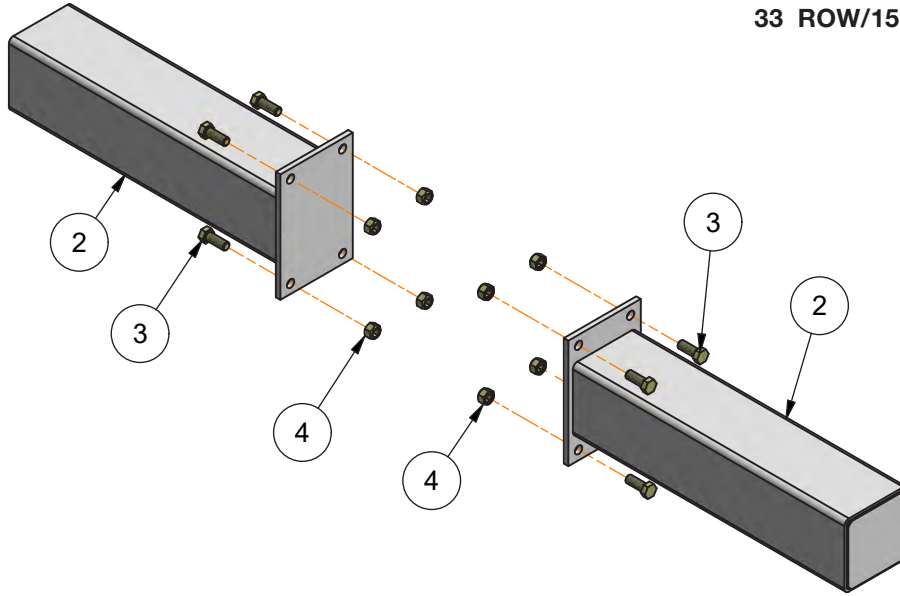

ITEM	PART NUMBER	DESCRIPTION	QTY	NOTES
	JAAM2642	Wing Extension Kit, 30"	1	Includes Items 2-4
2	JAM3533BB	Wing Extension Weldment	2	
3	9390-145	Capscrew, 3/4"-10UNC x 2" G5	8	
4	9802	Lock Nut, 3/4"-10UNC	8	

Coulter Offset Mounting Bracket, 10" x 4" (JAAM2180)

Please visit www.unverferth.com/parts/ for the most current parts listing.

27 ROW/18" - 40.5' TOOLBAR
 33 ROW/15" - 41.25' TOOLBAR
 35 ROW/20" - 58.33' TOOLBAR

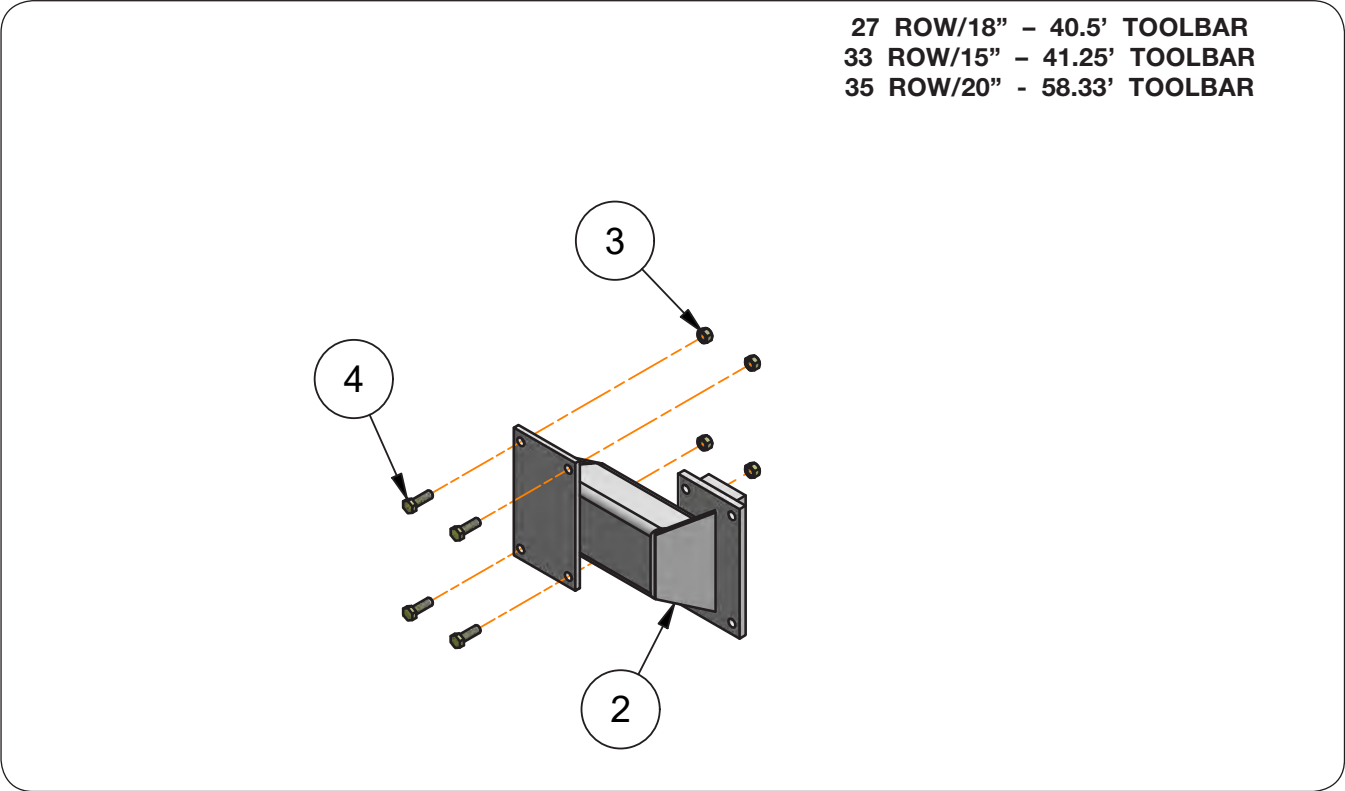

ITEM	PART NUMBER	DESCRIPTION	QTY	NOTES
	JAAM2180	Coulter Offset Mounting Bracket	1	includes items 2-4
2	JAM3574	Coulter Mounting Bracket Weldment	1	
3	9800	Lock Nut, 1/2"-13UNC	4	
4	9390-101	Capscrew, 1/2"-13UNC x 1 1/2" G5	4	

Coulter Offset Mounting Bracket, 15" x 4" (JAAM2721)

Please visit www.unverferth.com/parts/ for the most current parts listing.

23 ROW/30" – 57.5' TOOLBAR

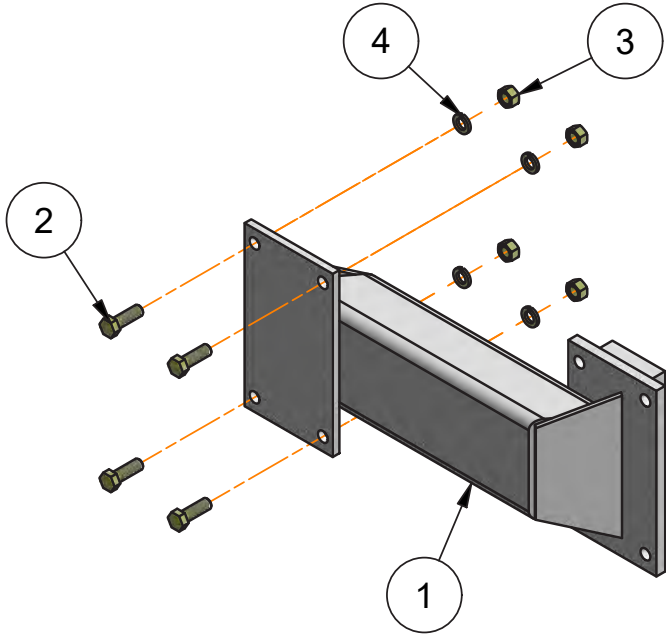

ITEM	PART NUMBER	DESCRIPTION	QTY	NOTES
	JAAM2721	Coulter Offset Mounting Bracket	1	Includes Items 1-4
1	JAM3640	Coulter Mounting Bracket Weldment	1	
2	9390-101	Capscrew, 1/2"-13UNC x 1 1/2" G5	4	
3	9394-010	Hex Nut, 1/2"-13UNC	4	
4	9404-025	Lock Washer, 1/2"	4	

Coulter 45° Angled Mounting Bracket (JAAM2436)

Please visit www.unverferth.com/parts/ for the most current parts listing.

25 ROW/20" - 42.5' TOOLBAR
 35 ROW/20" - 58.33' TOOLBAR

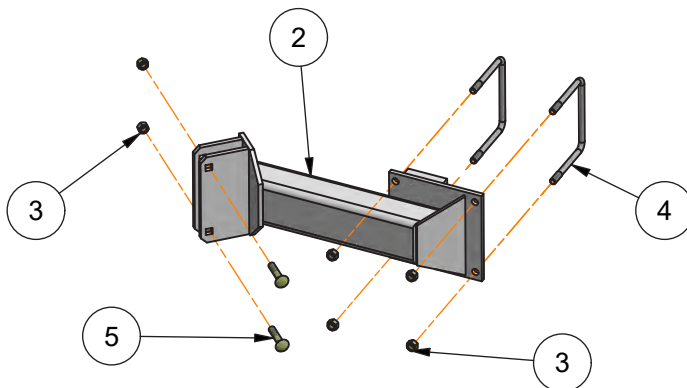

ITEM	PART NUMBER	DESCRIPTION	QTY	NOTES
	JAAM2436	Coulter 45° Angled Mounting Bracket Assembly	1	Includes Items 2-5
2	JAM3679	Coulter 45° Angled Mounting Bracket Weldment	1	
3	9800	Lock Nut, 1/2"-13UNC	6	
4	JBP3330	U-Bolt, 1/2"-13UNC x 5 1/8", 6 9/16" C/C G5	2	
5	9388-108	Carriage Bolt, 1/2"-13UNC x 2 1/2" G5	2	

Coulter Flatback Centered Mounting Bracket (JAAM2821)

Please visit www.unverferth.com/parts/ for the most current parts listing.

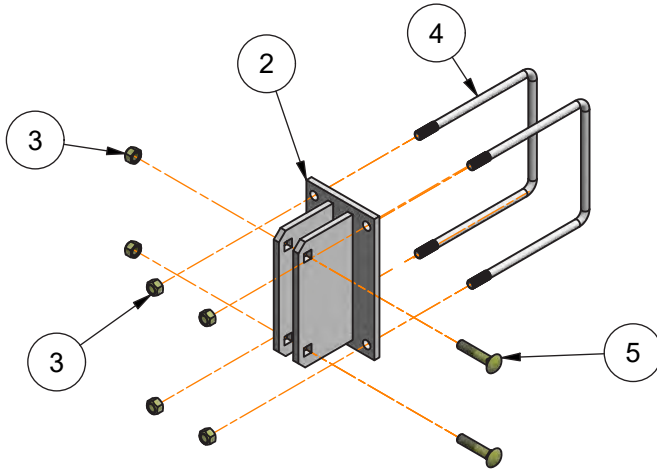

- 15 ROW/30" - 37.5' TOOLBAR
- 17 ROW/30" - 42.5' TOOLBAR
- 23 ROW/30" - 57.5' TOOLBAR
- 25 ROW/20" - 42.5' TOOLBAR
- 25 ROW/30" - 62.5' TOOLBAR
- 27 ROW/18" - 40.5' TOOLBAR
- 33 ROW/15" - 41.25' TOOLBAR
- 35 ROW/20" - 58.33' TOOLBAR

ITEM	PART NUMBER	DESCRIPTION	QTY	NOTES
	JAAM2821	Coulter Flatback Centered Mounting Bracket Assembly	1	Includes Items 2-5
2	JAM4425	Coulter Flatback Centered Mounting Bracket Weldment	1	
3	9800	Lock Nut, 1/2"-13UNC	6	
4	JBP3356	U-Bolt, 1/2"-13UNC x 8 1/4", 7 9/16" C/C G5	2	
5	9388-108	Carriage Bolt, 1/2"-13UNC x 2 1/2" G5	2	

Coulter Flatback Centered Mounting Bracket (JAAM2646)

Please visit www.unverferth.com/parts/ for the most current parts listing.

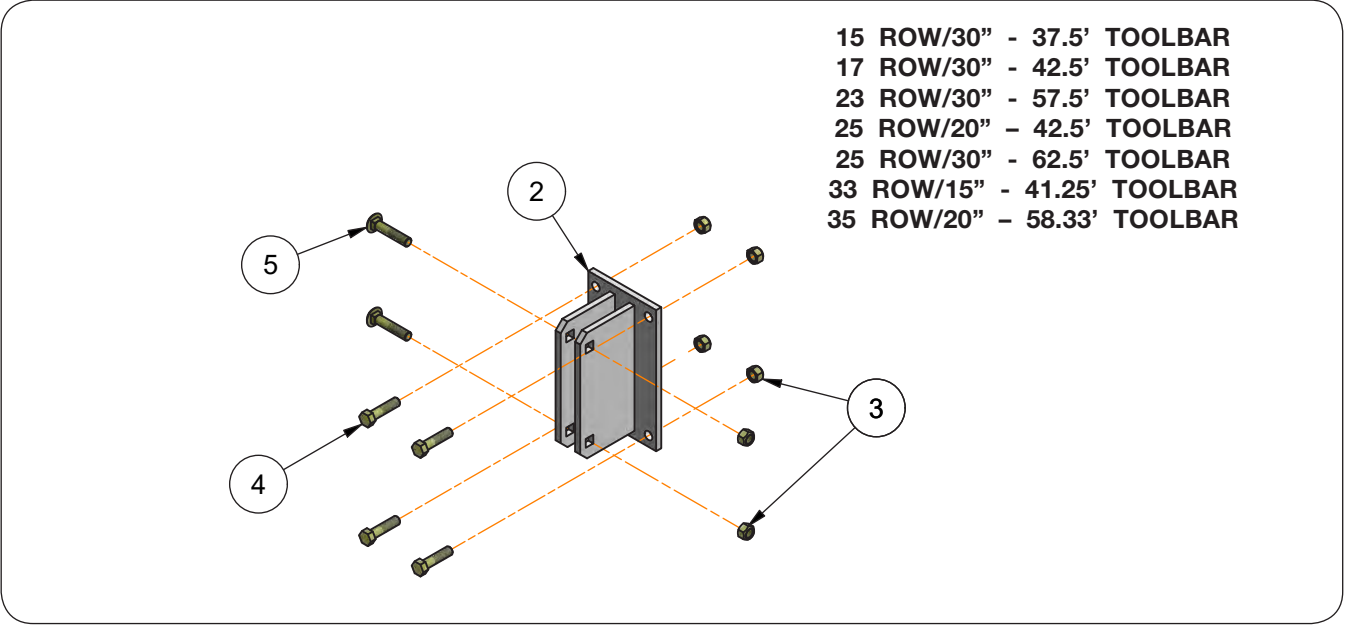

ITEM	PART NUMBER	DESCRIPTION	QTY	NOTES
	JAAM2646	Coulter Flatback Centered Mounting Bracket Assembly	1	Includes Items 2-5
2	JAM4425	Coulter Flatback Centered Mounting Bracket Weldment	1	
3	9800	Lock Nut, 1/2"-13UNC	6	
4	9390-103	Capscrew, 1/2"-13UNC x 2" G5	4	
5	9388-108	Carriage Bolt, 1/2"-13UNC x 2 1/2" G5	2	

Coulter Flatback Offset Mounting Bracket (JAAM2822)

Please visit www.unverferth.com/parts/ for the most current parts listing.

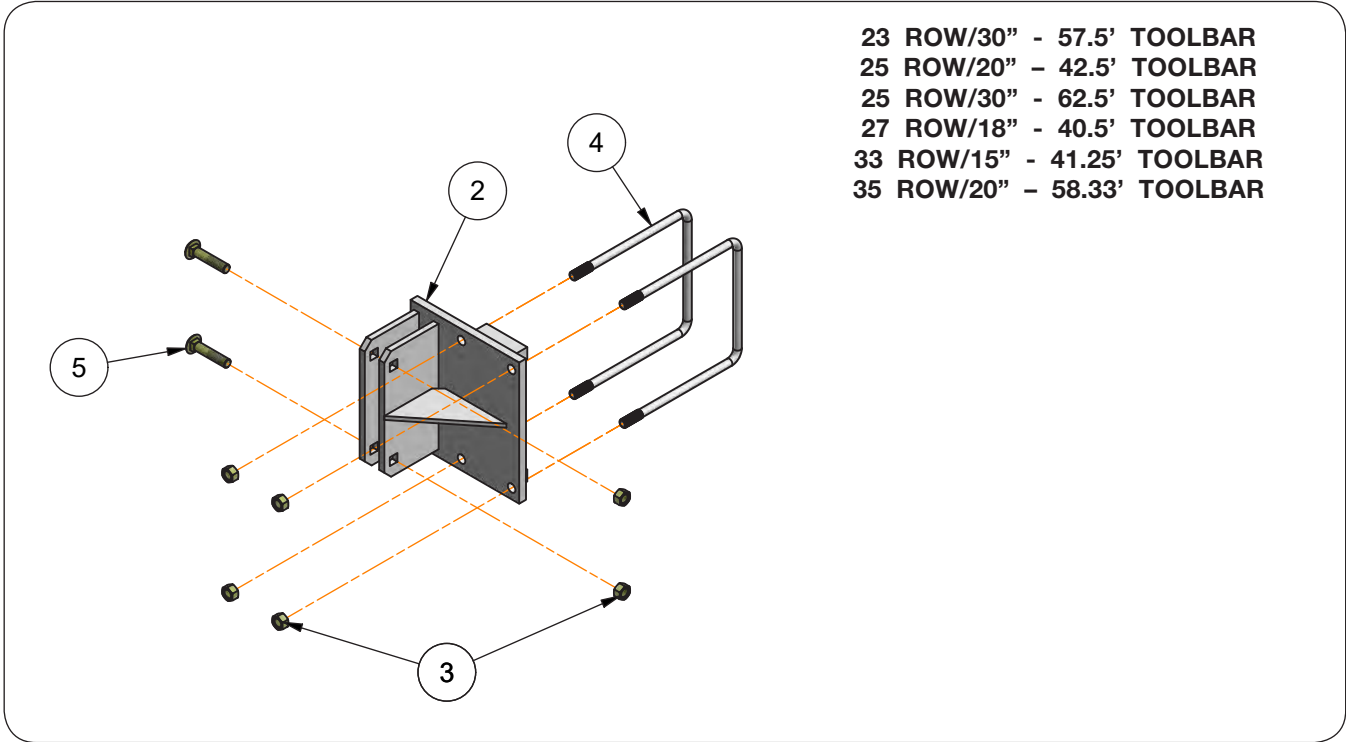

ITEM	PART NUMBER	DESCRIPTION	QTY	NOTES
	JAAM2822	Coulter Flatback Offset Mounting Bracket Assembly	1	Includes Items 2-5
2	JAM4435	Coulter Flatback Offset Mounting Bracket Weldment	1	
3	9800	Lock Nut, 1/2"-13UNC	6	
4	JBP3356	U-Bolt, 1/2"-13UNC x 8 1/4", 7 9/16" C/C G5	2	
5	9388-108	Carriage Bolt, 1/2"-13UNC x 2 1/2" G5	2	

Offset Mounting Bracket, 45" x 4" (JAAM2737)

Please visit www.unverferth.com/parts/ for the most current parts listing.

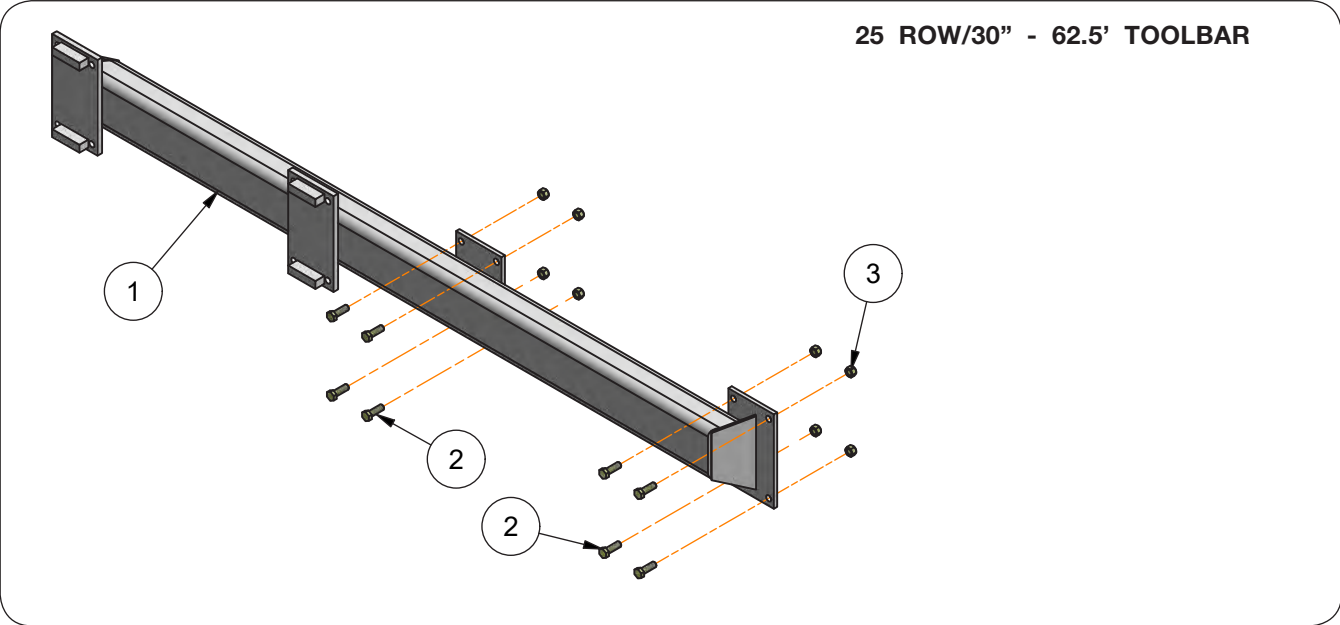

ITEM	PART NUMBER	DESCRIPTION	QTY	NOTES
1	JAM3671	Offset Mounting Bracket Weldment	1	
2	9390-101	Capscrew, 1/2"-13UNC x 1 1/2" G5	8	
3	9800	Lock Nut, 1/2"-13UNC	8	

Offset Mounting Bracket, 25" x 4" (JAAM2739)

Please visit www.unverferth.com/parts/ for the most current parts listing.

35 ROW/20" - 58.33' TOOLBAR

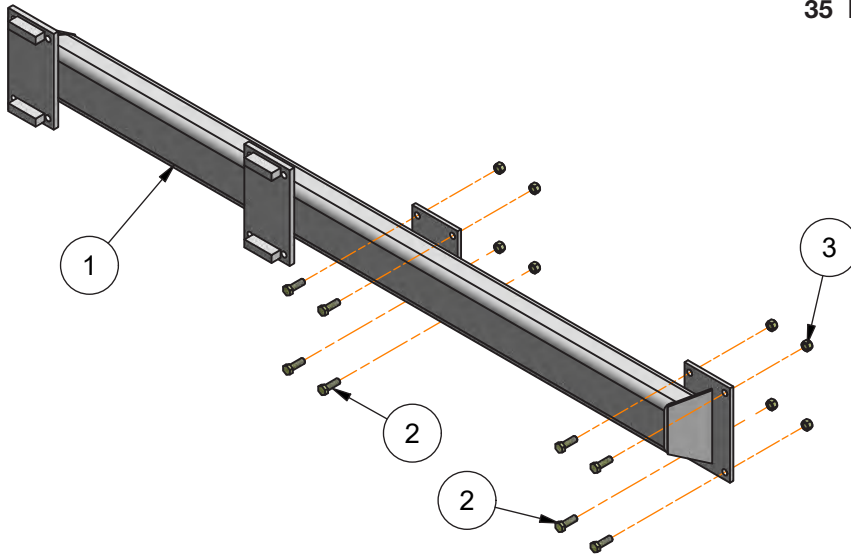

ITEM	PART NUMBER	DESCRIPTION	QTY	NOTES
1	JAM3675	Offset Mounting Bracket Weldment	1	
2	9390-101	Capscrew, 1/2"-13UNC x 1 1/2" G5	8	
3	9800	Lock Nut, 1/2"-13UNC	8	

Stagger Flatback Spacer (JAAM2740)

Please visit www.unverferth.com/parts/ for the most current parts listing.

23 ROW/30" - 57.5' TOOLBAR
 25 ROW/30" - 62.5' TOOLBAR
 35 ROW/20" - 58.33' TOOLBAR

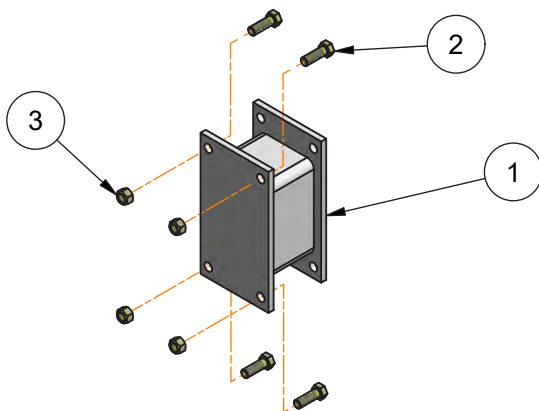

ITEM	PART NUMBER	DESCRIPTION	QTY	NOTES
1	JAM3677	Stagger Flatback Spacer Weldment	1	
2	9390-101	Capscrew, 1/2"-13UNC x 1 1/2" G5	8	
3	9800	Lock Nut, 1/2"-13UNC	8	

Bolt-On Coultter Bar Assembly (JAAM2908)

Please visit www.unverferth.com/parts/ for the most current parts listing.

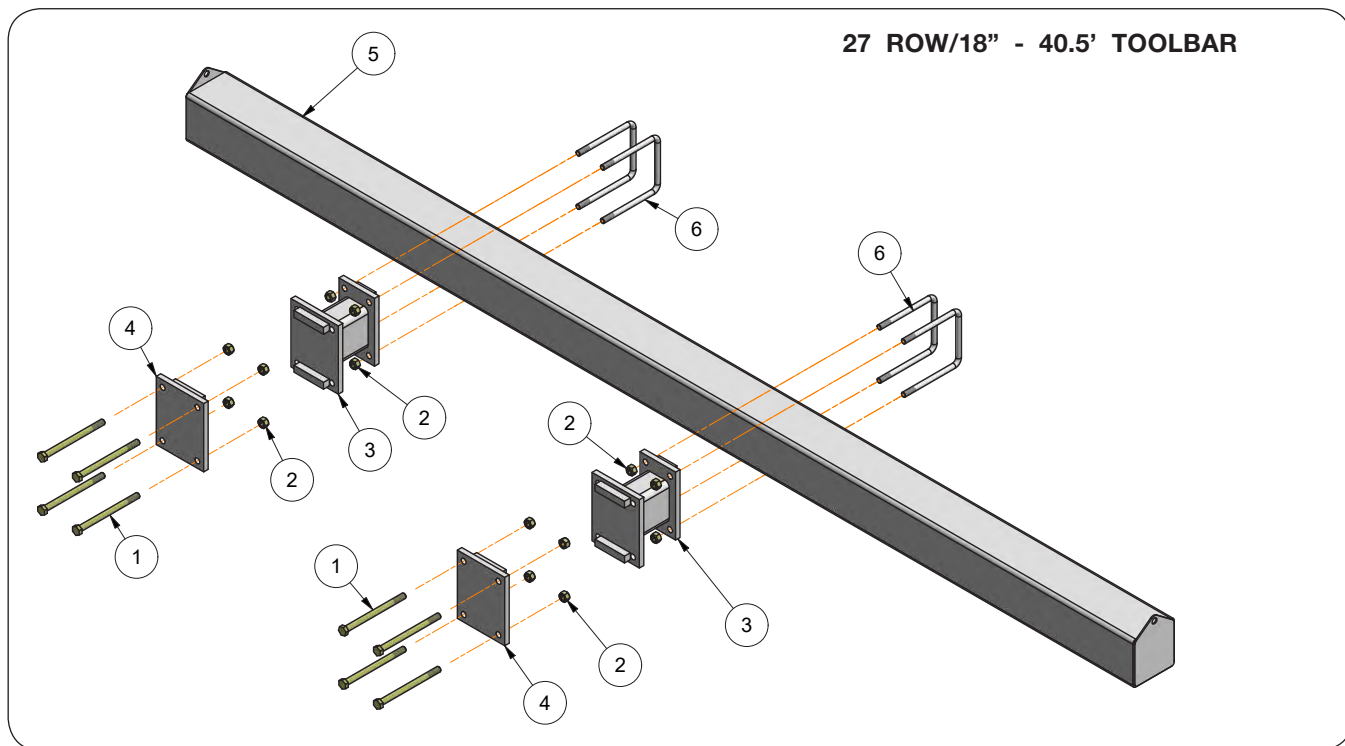

ITEM	PART NUMBER	DESCRIPTION	QTY	NOTES
	JAAM2908	Bolt-On Coultter Bar Assembly	-	
1	9390-450	Capscrew, 3/4"-10UNC x 10" G5	8	
2	9802	Lock Nut, 3/4"-10UNC	16	
3	JAM3577	Mounting Bracket	2	
4	JAM3578	Backing Plate	2	
5	JAM3581	Bolt-On Toolbar Weldment	1	
6	JBP3058	U-Bolt, 3/4"-10UNC x 9", 7 13/16" C/C G5	4	

Gauge Wheel Legs RH/LH Pair, Vertical Pin Adjust

Please visit www.unverferth.com/parts/ for the most current parts listing.

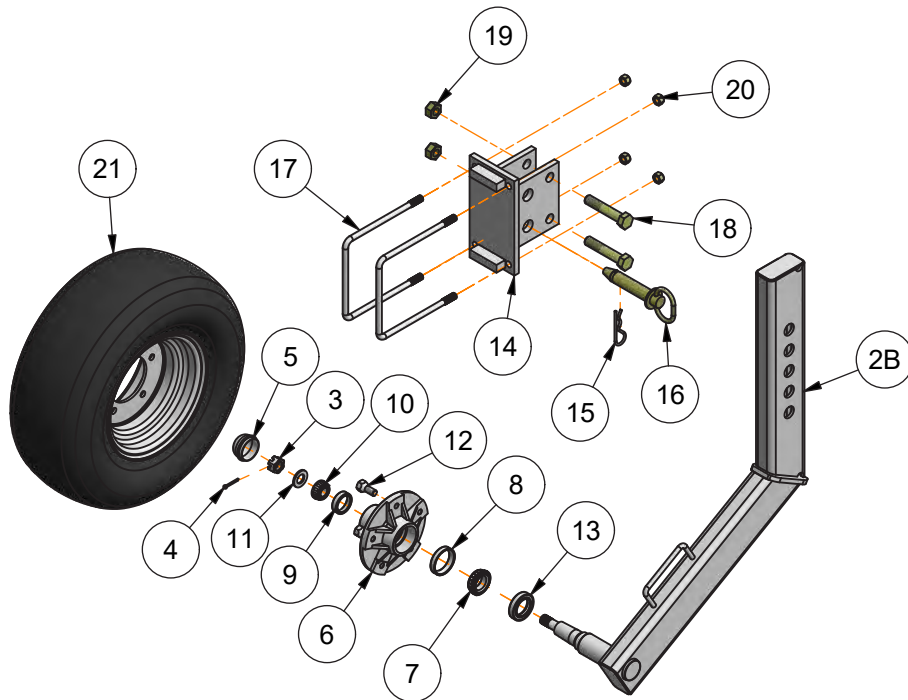
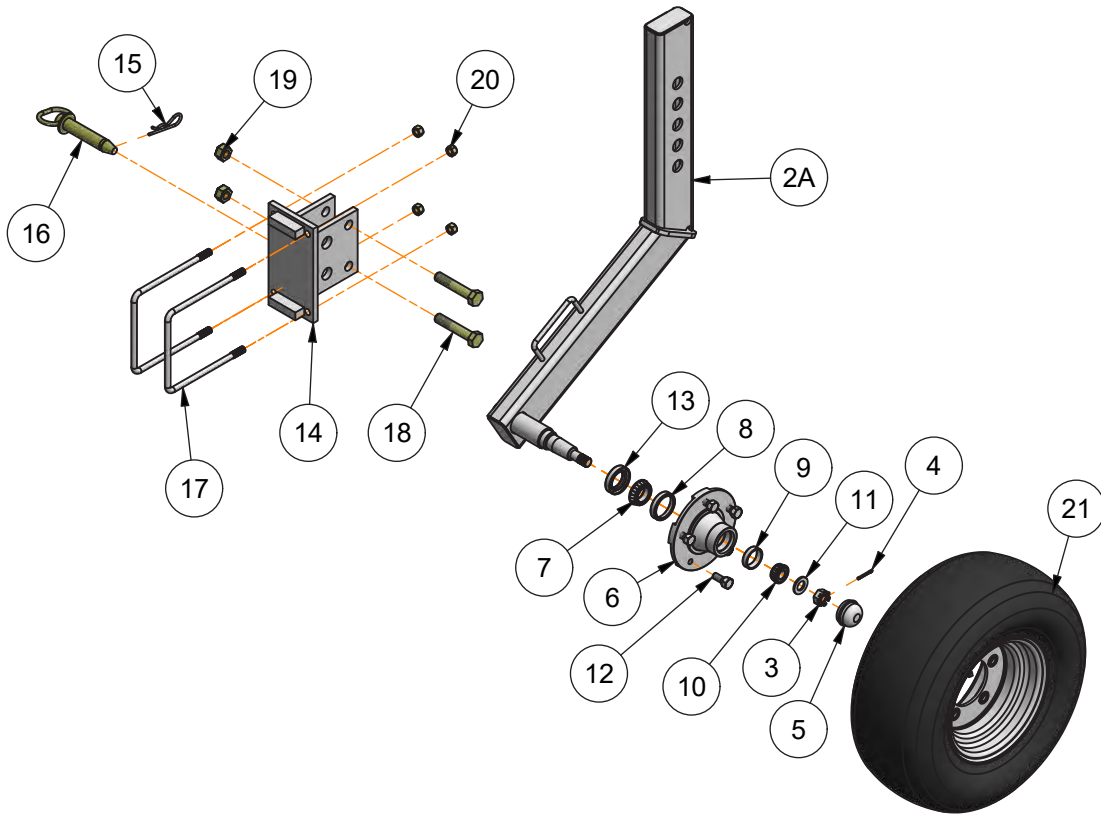

Gauge Wheel Legs RH/LH Pair, Vertical Pin Adjust

Please visit www.unverferth.com/parts/ for the most current parts listing.

ITEM	PART NUMBER	DESCRIPTION	QTY	NOTES
1A	JAM3585	Gauge Wheel Leg LH Assembly	1	Includes Items 2A, 3-13
1B	JAM3586	Gauge Wheel Leg RH Assembly	1	Includes Items 2B, 3-13
2A	JEM7675	Gauge Wheel Leg Weldment LH	1	
2B	JEM7676	Gauge Wheel Leg Weldment RH	1	
3	9393-016	Slotted Nut, 3/4"-16UNF G2	1	
4	9391-034	Cotter Pin 5/32" Dia. x 1 1/4"	1	
5	9787	Hub Cap	1	
6	9503449B	Hub 5 Bolt Assembly Complete (Model 511)	1	Includes Items 7-13
7	9165	Bearing Cone 1.2500" Bore (LM67048)	1	
8	9345	Bearing Cup 2.328" OD (LM67010)	1	
9	9784	Bearing Cup 1.780" OD (LM11910)	1	
10	9789	Bearing Cone 0.75" ID (LM11949)	1	
11	91050	Flat Washer 1.469" OD x 0.812" ID	1	
12	91829	Wheel Bolt, 1/2"-20UNF x 1 5/8" G5	5	
13	JAP2747	Seal, 2.328" OD x 1.500" ID Double Lip with Garter Spring	1	
14	JAM3587	Gauge Wheel Bracket Weldment Mounting 2" Wide	2	
15	JBP3500	Hairpin Cotter, 0.172" Dia. x 3 1/2"	2	
16	JBP3475	Hitch Pin, 1" Dia. x 4"	2	
17	JBP3356	U-Bolt, 1/2"-13UNC x 8 1/4", 7 9/16" C/C G5	4	
18	9390-153	Capscrew, 3/4"-10UNC x 4" G5	4	
19	96732	Lock Nut/Center, 3/4"-10UNC	4	
20	9800	Lock Nut/Top, 1/2"-13UNC	8	
21	9503258SM	Wheel & Tire Assembly, 6 x 10 Wheel, TL20.5x8.0B10CA	2	

Super 1200 Coulter Assembly Components (JAAM2730)

Please visit www.unverferth.com/parts/ for the most current parts listing.

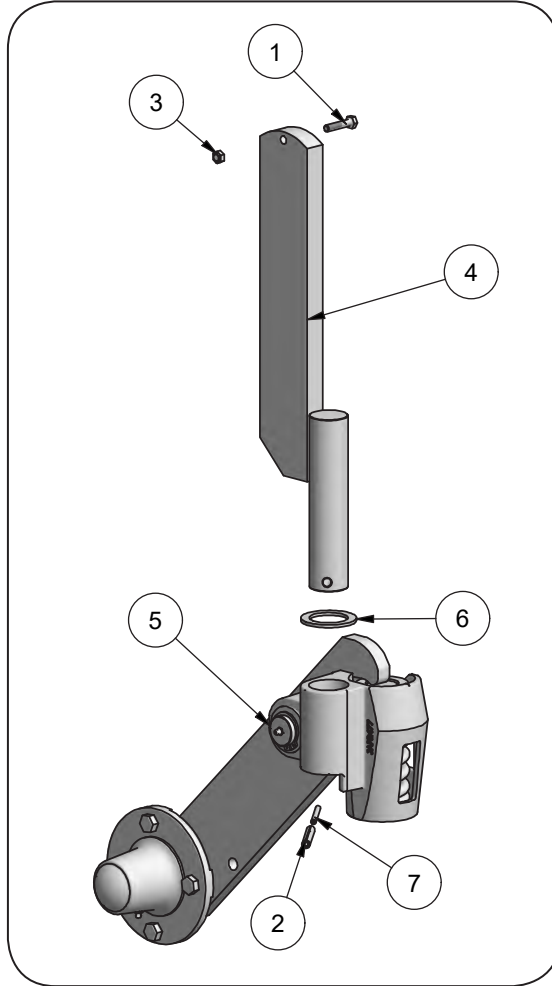

ITEM	PART NUMBER	DESCRIPTION	QTY	NOTES
	JAAM2730	Super 1200 Coulter & 23" Shank, 1 Row	1	Includes Items 1-7
1	9390-032	Capscrew, 5/16"-18UNC x 1 1/2"	1	
2	9392-182	Roll Pin, 3/8" Dia. x 2 1/2"	1	
3	9807	Lock Nut/Top, 5/16"-18UNC	1	
4	JAM4424	Coulter Shank, 23"	1	
5	JAM2799	Coulter Arm w/Hub & Knee Casting Assembly	1	
6	JBP3466	Machinery Bushing, 2-1/2" x 1-3/4"X 10 Gauge, Stainless Steel	1	
7	JBP3534	Roll, Pin, 7/32" Dia. x 2 1/2"	1	

Coulter Arm, Hub & Knee Components (JAM2799)

Please visit www.unverferth.com/parts/ for the most current parts listing.

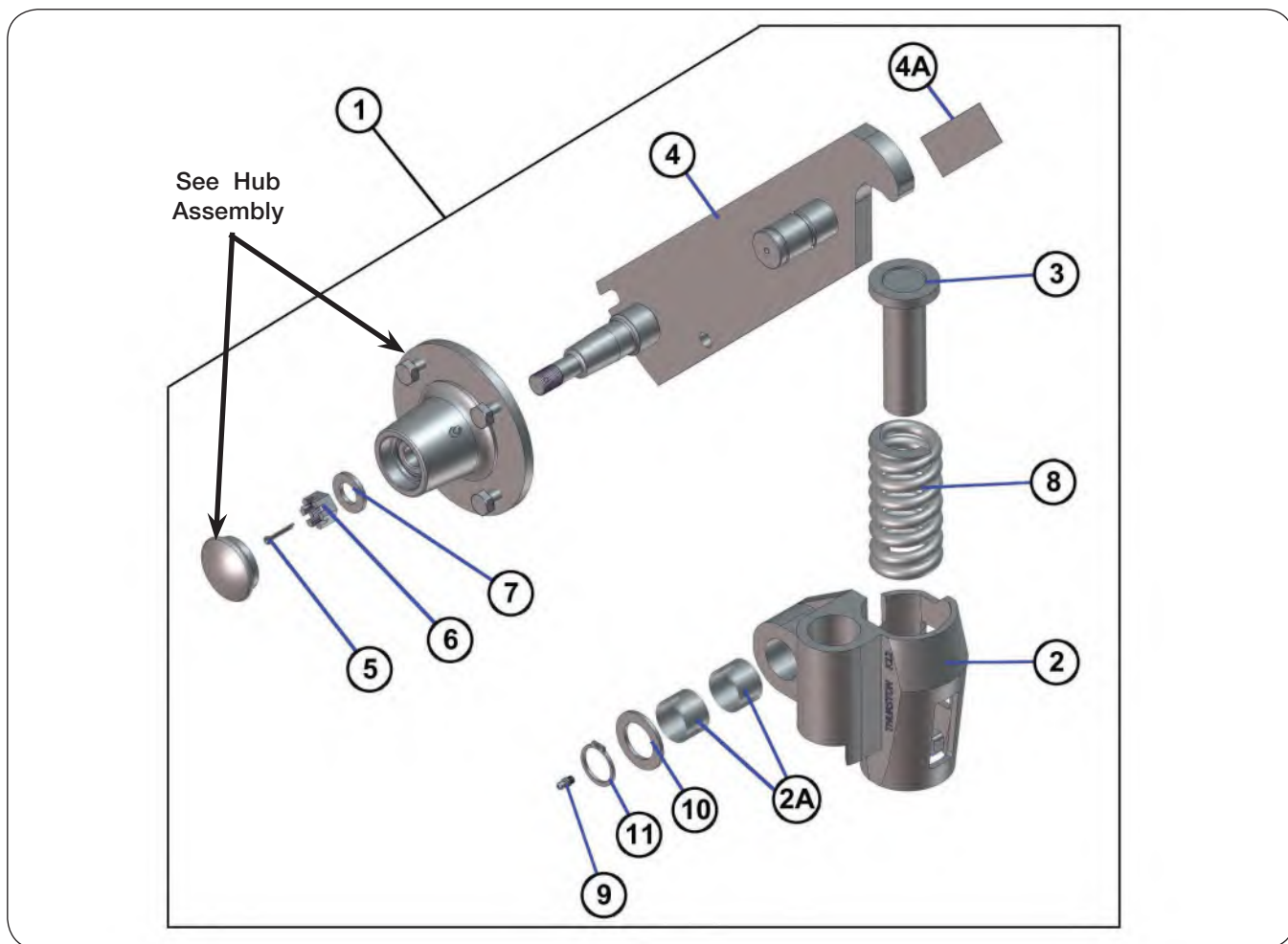

ITEM	QTY	PART NUMBER	DESCRIPTION	NOTES
1	1	JAM2799	Coulter Arm Assembly With Hub & Knee Casting, HD	
2	1	JAM2743B	Casting, Coulter Knee, HD, Machined With Bushings	
2A	2	JAP2274	Bushing, 1 17/32" OD x 1 3/8" ID" x 1" OAL	
3	1	JAM2796PL	Spring Cap & Guide, HD Coulter	
4	1	JAM2797	Coulter Arm, HD	
4A	1	JAP2216	Decal, BLU-JET, Small, 1 1/2" x 4"	
5	1	9391-034	Pin, Cotter, 5/32" Dia. x 1 1/2"	
6	1	9393-016	Nut, Spindle, 3/4"-16UNC	
7	1	91050	Washer, Spindle, 1 1/2" x 13/16" x .134"	
8	1	JAP2881B	Compression Spring, 2.472" OD x 5.875" OAL, .468 Wire Dia.	
9	1	91160	Grease Zerk, 1/4"-28	
10	1	JBP3404	Machinery Bushing, 2 1/8" OD x 1 3/8" ID x 10 GA.	
11	1	91575	Retaining Ring, 1 3/8" Dia.	

Hub Assembly, 4-Bolt Components (JAP2707)

Please visit www.unverferth.com/parts/ for the most current parts listing.

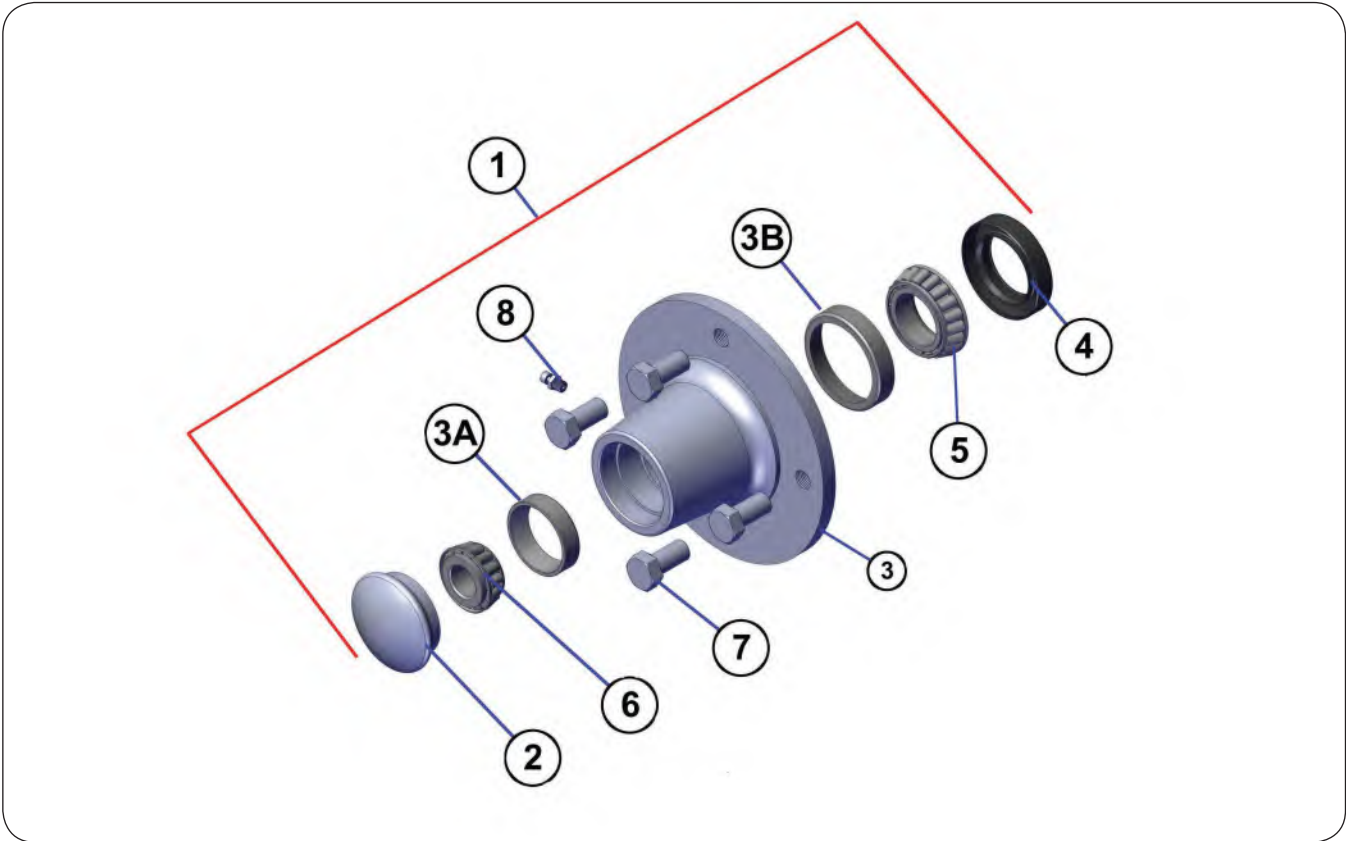

ITEM	QTY	PART NUMBER	DESCRIPTION	NOTES
1	1	JAP2707	Hub Assembly, 4 Bolt	
2	1	90024	Hub Cap, 1610	
3	1	JAP2706-1	Hub W/ Cups, 4 Bolt, 5" BC, 3.62" Pilot, W/Zerk Hole	
3A	1	9784	Bearing Cup, LM11910	
3B	1	9345	Bearing Cup, LM67010	
4	1	JAP2747	Grease Seal, 15235TB	
5	1	9165	Bearing Cone, LM67048	
6	1	9789	Bearing Cone, LM11949	
7	4	9390-323	Capscrew, 1/2"-20UNF x 1", G5	
8	1	91160	Grease Zerk, 1/4"-28	

Coulter Blade (JAP2840)

Please visit www.unverferth.com/parts/ for the most current parts listing.

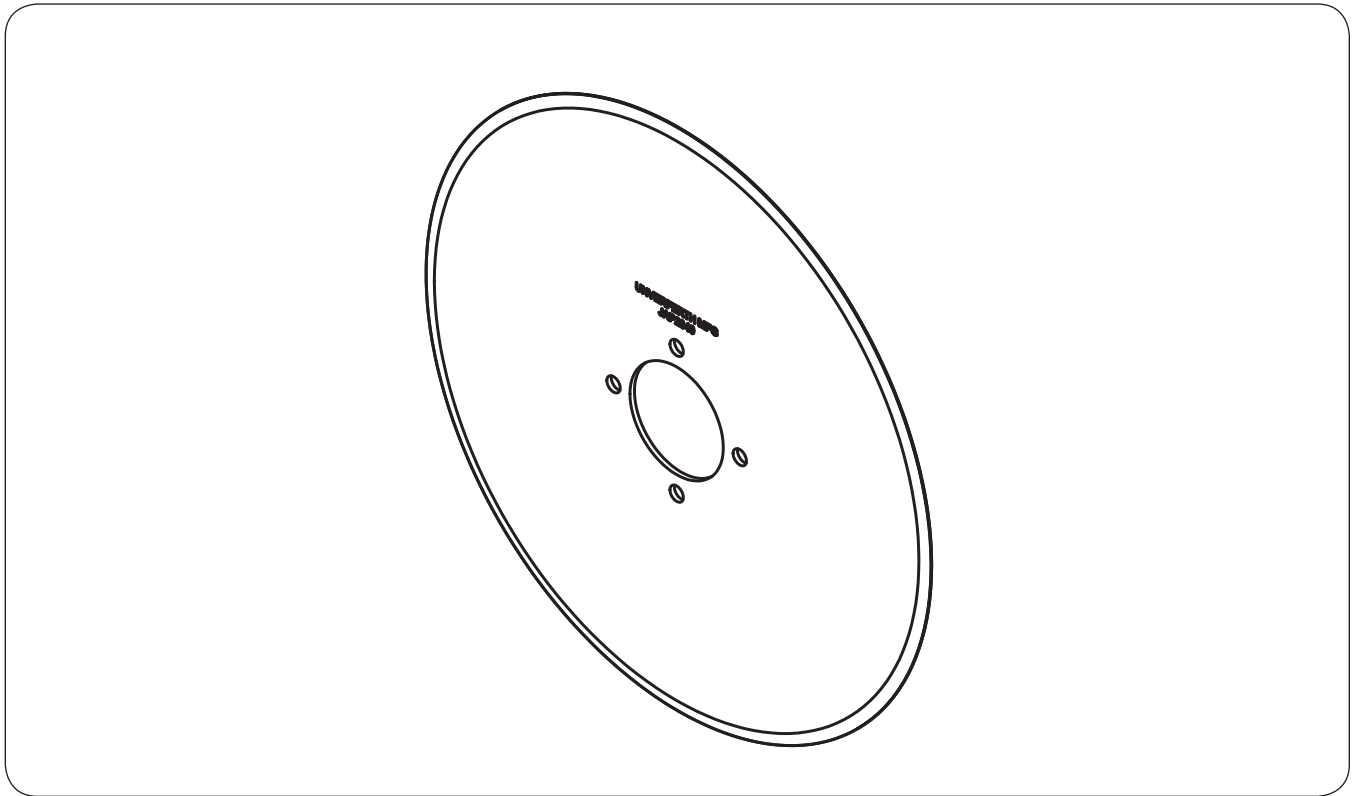

ITEM	QTY	PART NUMBER	DESCRIPTION	NOTES
1	1	JAP2840	Coulter Blade 20" Dia. Smooth	

AT4615 — Parts

Narrow Fold Transport Coupler Option (43468) (Double Tube Toolbar)

Please visit www.unverferth.com/parts/ for the most current parts listing.

23 ROW/30" - 57.5' TOOLBAR
25 ROW/30" - 62.5' TOOLBAR

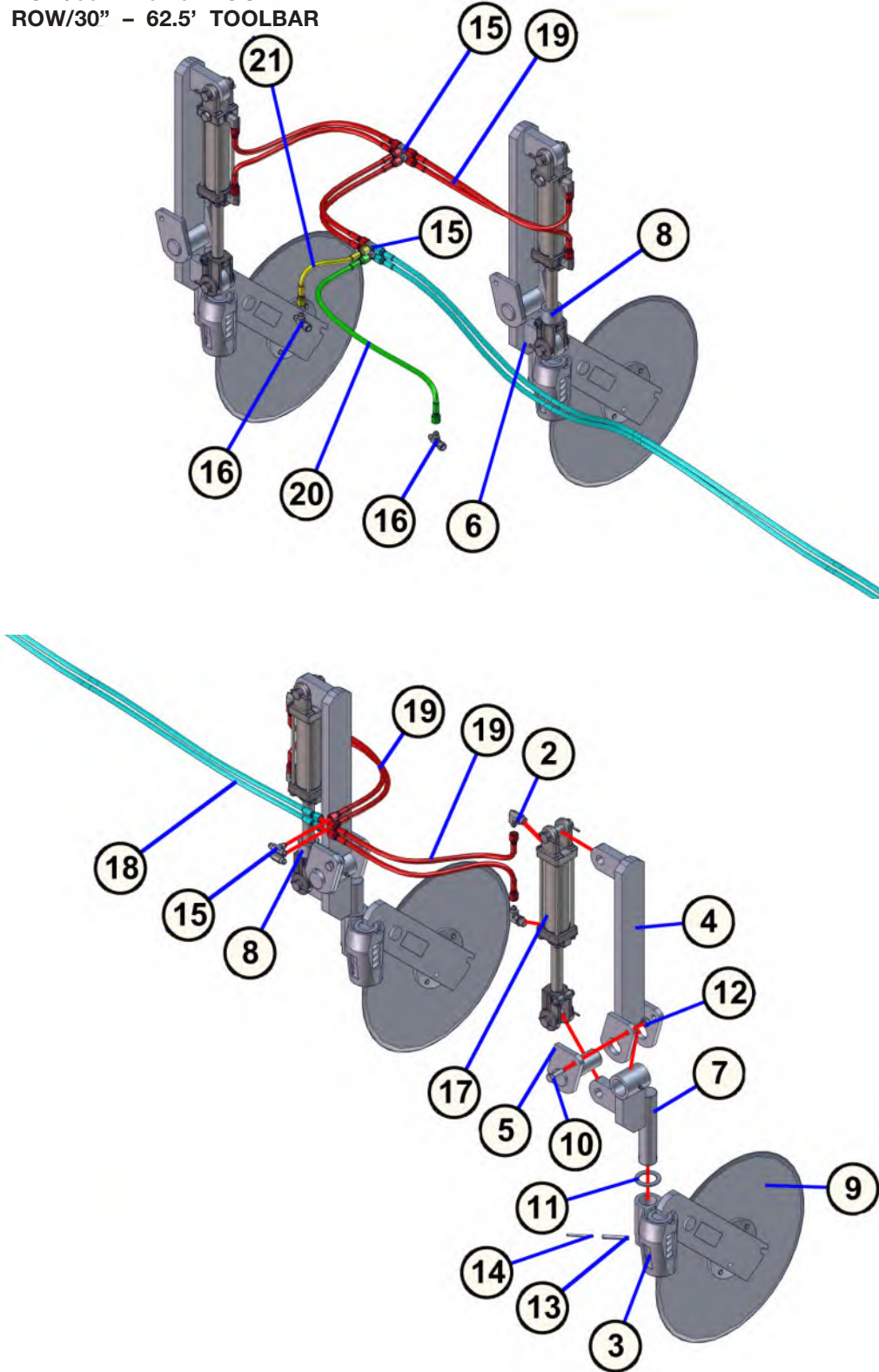

Narrow Fold Transport Coulter Option (43468) (Double Tube Toolbar)

Please visit www.unverferth.com/parts/ for the most current parts listing.

ITEM	PART NUMBER	DESCRIPTION	QTY
1	43468	Narrow Fold Transport Coulter Option (4 Pair) Includes Items 2, 4-8, 10, 12, 15-21	-
2	JAAM2111	90° Elbow, 9/16-18 JIC Male x 3/4-10 O-Ring Male w/1/8" Restrictor	16
3	JAM2799	Coulter Arm Assembly w/Hub & Knee Casting	4
4	JAM3620	Folding Coulter Shank Weldment	8
5	JAM3621	Pin, Folding Coulter Shank	8
6	JAM3622	Coulter Mounting Weldment #1, Folding Coulter Shank	4
7	JAM3623	Coulter Mounting Weldment #2, Folding Coulter Shank	4
8	JAM3680	Spacer/Tube 2" OD x 1.250" ID x 1 1/2"	8
9	JAP2840	Coulter Blade 20" Dia. Smooth	4
10	9390-101	Capscrew, 1/2"-13UNC x 1 1/2" G5	8
11	JBP3205	Machinery Bushing, 2 1/2" OD x 1 3/4" ID	4
12	94981	Lock Nut/Center, 1/2"-13UNC	8
13	9392-182	Roll Pin, 3/8" Dia. x 2 1/2"	4
14	JBP3534	Roll Pin, 7/32" Dia. x 2 1/2"	4
15	9875	Tee, 9/16-18 JIC Male x 9/16-18 JIC Male x 9/16-18 JIC Male	12
16	91465	Tee, 9/16-18 JIC Male x 9/16-18 JIC Female x 9/16-18 JIC Male	4
17	JDP4553	Hydraulic Cylinder, 2 x 6	8
18	JDP5038	Hydraulic Hose, 1/4" x 108" (9/16-18 JIC Female x 9/16-18 JIC Female)	2
19	JDP5060	Hydraulic Hose, 1/4" x 24" (9/16-18 JIC Female x 9/16-18 JIC Female)	20
20	JDP5138	Hydraulic Hose, 1/4" x 33" (9/16-18 JIC Female x 9/16-18 JIC Female)	2
21	JDP5239	Hydraulic Hose, 1/4" x 12" (9/16-18 JIC Female x 9/16-18 JIC Female)	2

NOTE: Secondary and Third wing cylinders must have pressure on during field operation when optional folding coulters are used.

AT4615 — Parts

Narrow Fold Transport Coupler Option (43679) (Single Tube Toolbar)

Please visit www.unverferth.com/parts/ for the most current parts listing.

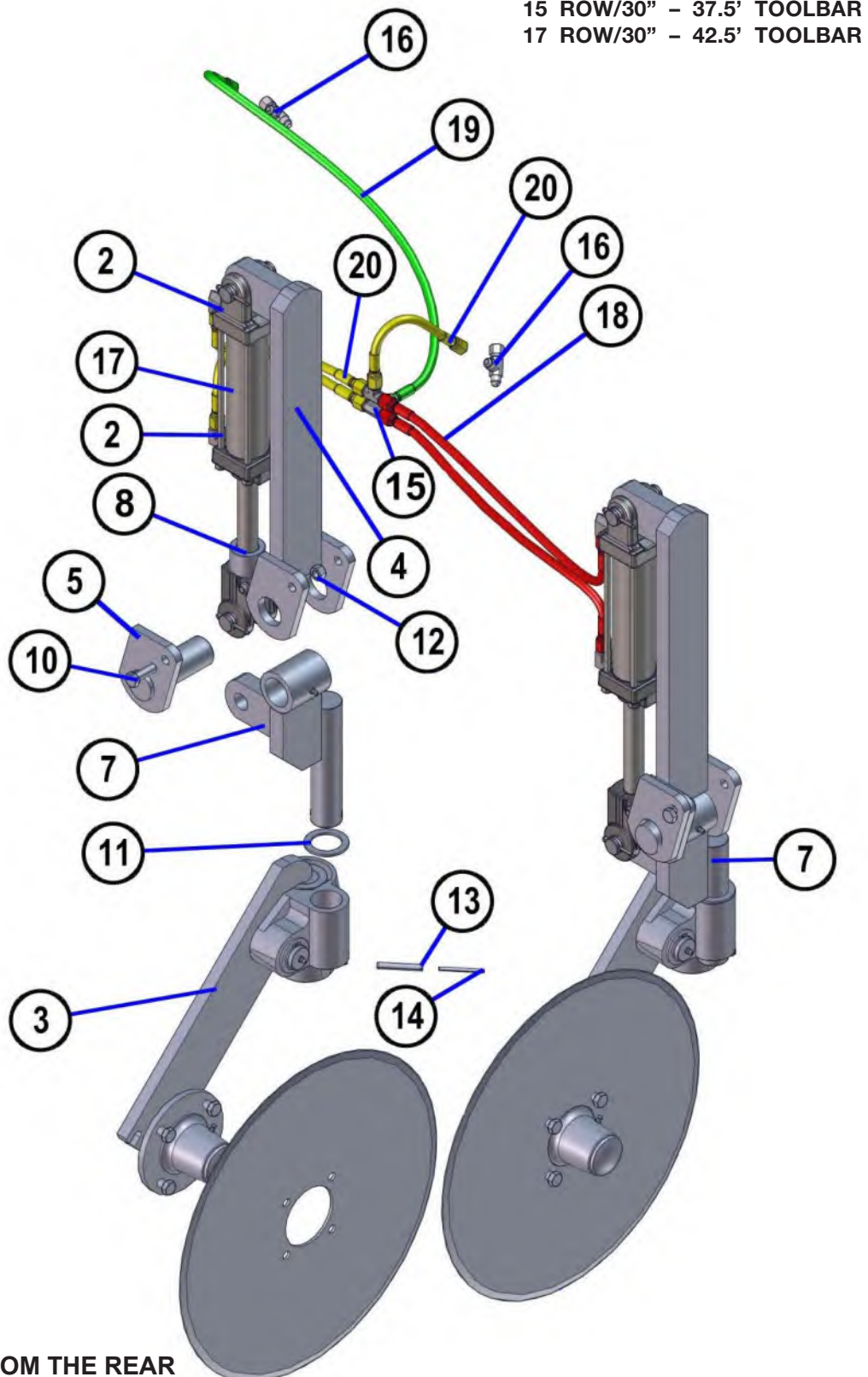

AT4615 — Parts

Narrow Fold Transport Coulter Option (43679) (Single Tube Toolbar)

Please visit www.unverferth.com/parts/ for the most current parts listing.

ITEM	PART NUMBER	DESCRIPTION	QTY
1	43679	Narrow Fold Transport Coulter Option (2 Pair) Includes Items 2, 4-8, 10, 12, 15-20	-
2	JAAM2111	90° Elbow, 9/16-18 JIC Male x 3/4-10 O-Ring Male w/1/8" Restrictor	8
3	JAM2799	Coulter Arm Assembly w/Hub & Knee Casting	4
4	JAM3620	Folding Coulter Shank Weldment	4
5	JAM3621	Pin, Folding Coulter Shank	4
6	JAM3622	Coulter Mounting Weldment #1, Folding Coulter Shank	2
7	JAM3623	Coulter Mounting Weldment #2, Folding Coulter Shank	2
8	JAM3680	Spacer/Tube 2" OD x 1.250" ID x 1 1/2"	2
9	JAP2840	Coulter Blade 20" Dia. Smooth	4
10	9390-101	Capscrew, 1/2"-13UNC x 1 1/2" G5	4
11	JBP3205	Machinery Bushing, 2 1/2" OD x 1 3/4" ID	4
12	94981	Lock Nut/Center, 1/2"-13UNC	4
13	9392-182	Roll Pin, 3/8" Dia. x 2 1/2"	4
14	JBP3534	Roll Pin, 7/32" Dia. x 2 1/2"	4
15	9875	Tee, 9/16-18 JIC Male x 9/16-18 JIC Male x 9/16-18 JIC Male	4
16	91465	Tee, 9/16-18 JIC Male x 9/16-18 JIC Female x 9/16-18 JIC Male	4
17	JDP4553	Hydraulic Cylinder, 2 x 6	4
18	JDP5060	Hydraulic Hose, 1/4" x 24" (9/16-18 JIC Female x 9/16-18 JIC Female)	4
19	JDP5138	Hydraulic Hose, 1/4" x 33" (9/16-18 JIC Female x 9/16-18 JIC Female)	2
20	JDP5239	Hydraulic Hose, 1/4" x 12" (9/16-18 JIC Female x 9/16-18 JIC Female)	6

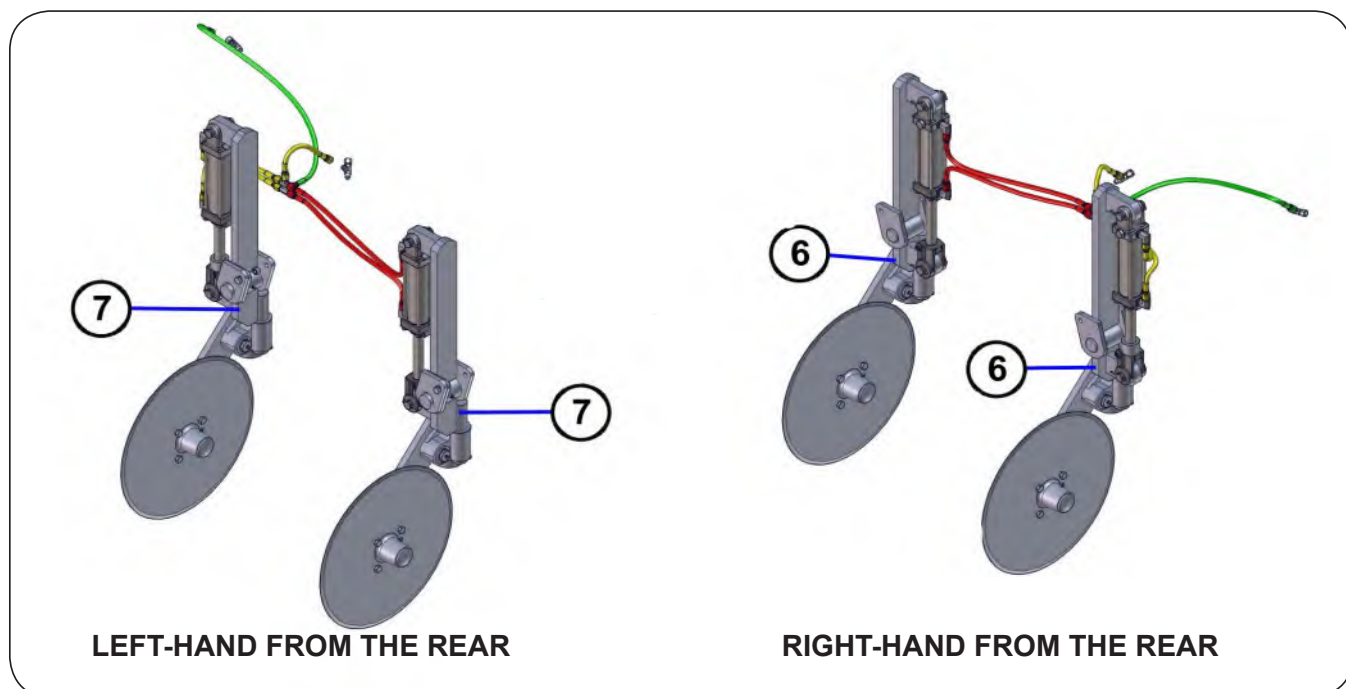

Jetstream Coultter Knife Assembly Components (JAAM3356)

Please visit www.unverferth.com/parts/ for the most current parts listing.

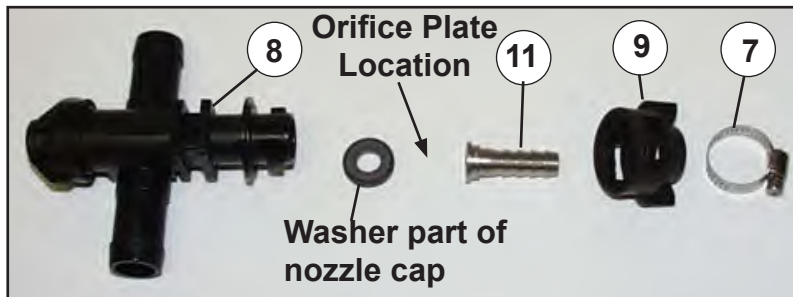
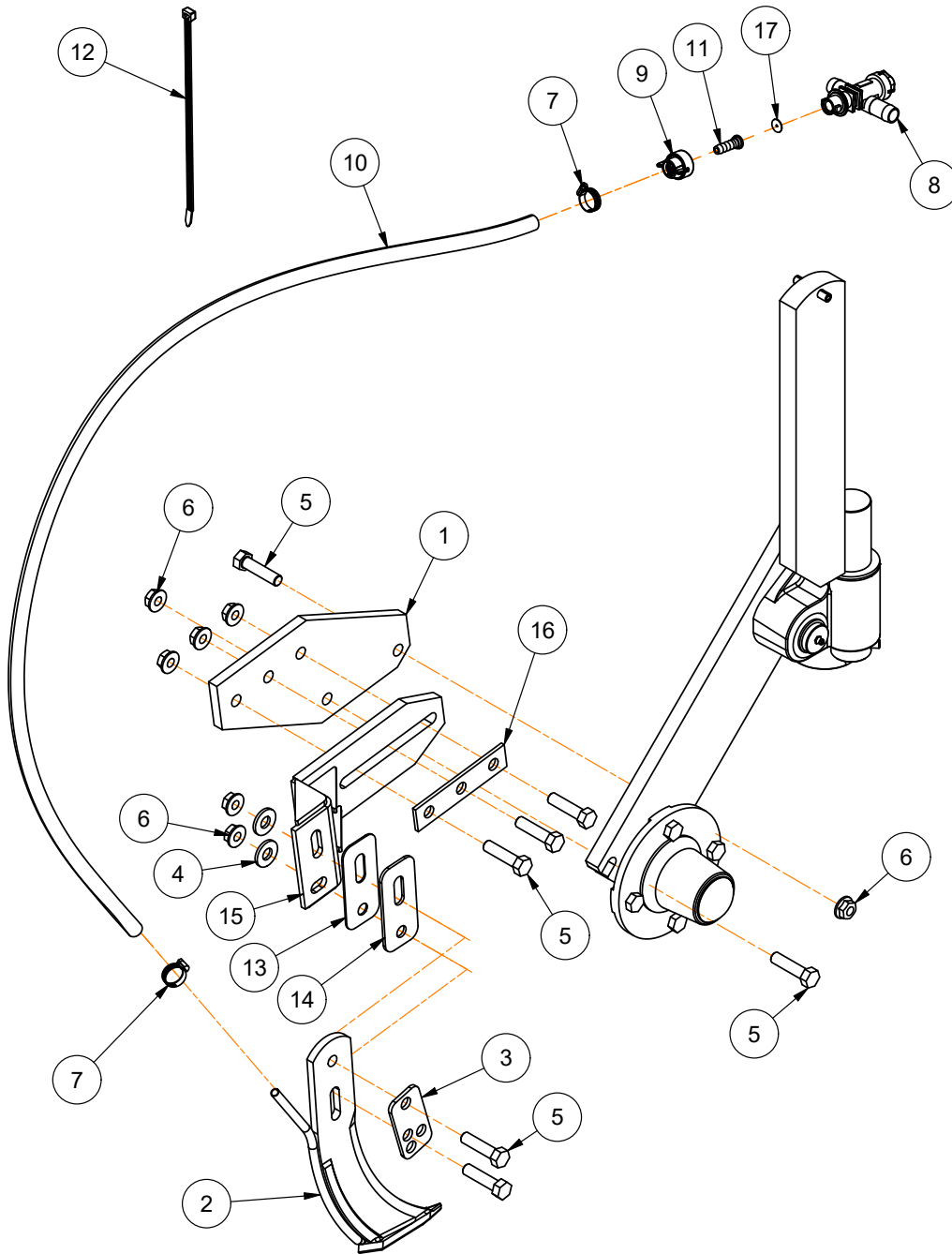

Jetstream Coultter Knife Assembly Components (JAAM3356)

Please visit www.unverferth.com/parts/ for the most current parts listing.

ITEM	QTY	PART NUMBER	DESCRIPTION	NOTES
	1	JAAM3356	Coultter Knife Assembly, W/Knife, Tee-Jet Check	Includes Items 1-17
1	1	JAM3324	Adapter Plate, Coultter Knife	
2	1	67923	Liquid Fertilizer Knife 3/8" Extra Thin	
3	1	JAM3591	Washer, Coultter Knife	
4	4	JAP2422	Machinery Bushing, 1.25 OD x 9/16 ID x .135	
5	4	9390-103	Capscrew, 1/2"-13UNC x 2", G5	
6	6	9003397	Lock Nut/Top, 1/2"-13UNC	
7	2	TA800902	Hose Clamp, Worm Gear, 1/4" - 5/8" Tubing, SS	
8	1	TA886025	Nozzle Body/Single QJ 3/4" Tee	
9	1	9007736	Quick Nozzle Cap Assembly	
10	1	44279	Hose, 3/8" x 60", EPDM Rubber	
11	1	JCP5046	Hose Barb Insert, 3/8, Stainless Steel	
12	3	9003735	Cable Tie 11" Standard	
13	1	44579	Shim Plate, 14GA.	
14	1	44580	Shim Plate, 10GA.	
15	1	44826B	Knife Holder Weldment Mounting Arm	
16	1	44637B	Backing Plate	
17	1	JCP2544	Orifice Plate #4916-86 Jetstream	
	1	JCP2545	Orifice Plate #4916-95 Jetstream	
	1	TA862052	Orifice Plate #4916-110 Jetstream	
	1	TA862054	Orifice Plate #4916-120 Jetstream	
	1	JCP2571	Orifice Plate #4916-136 Jetstream	

AT4615 — Parts

Jetstream Liquid Assembly Components Tee-Jet Check (JAAM3353); Low Rate (JAAM3355)

Please visit www.unverferth.com/parts/ for the most current parts listing.

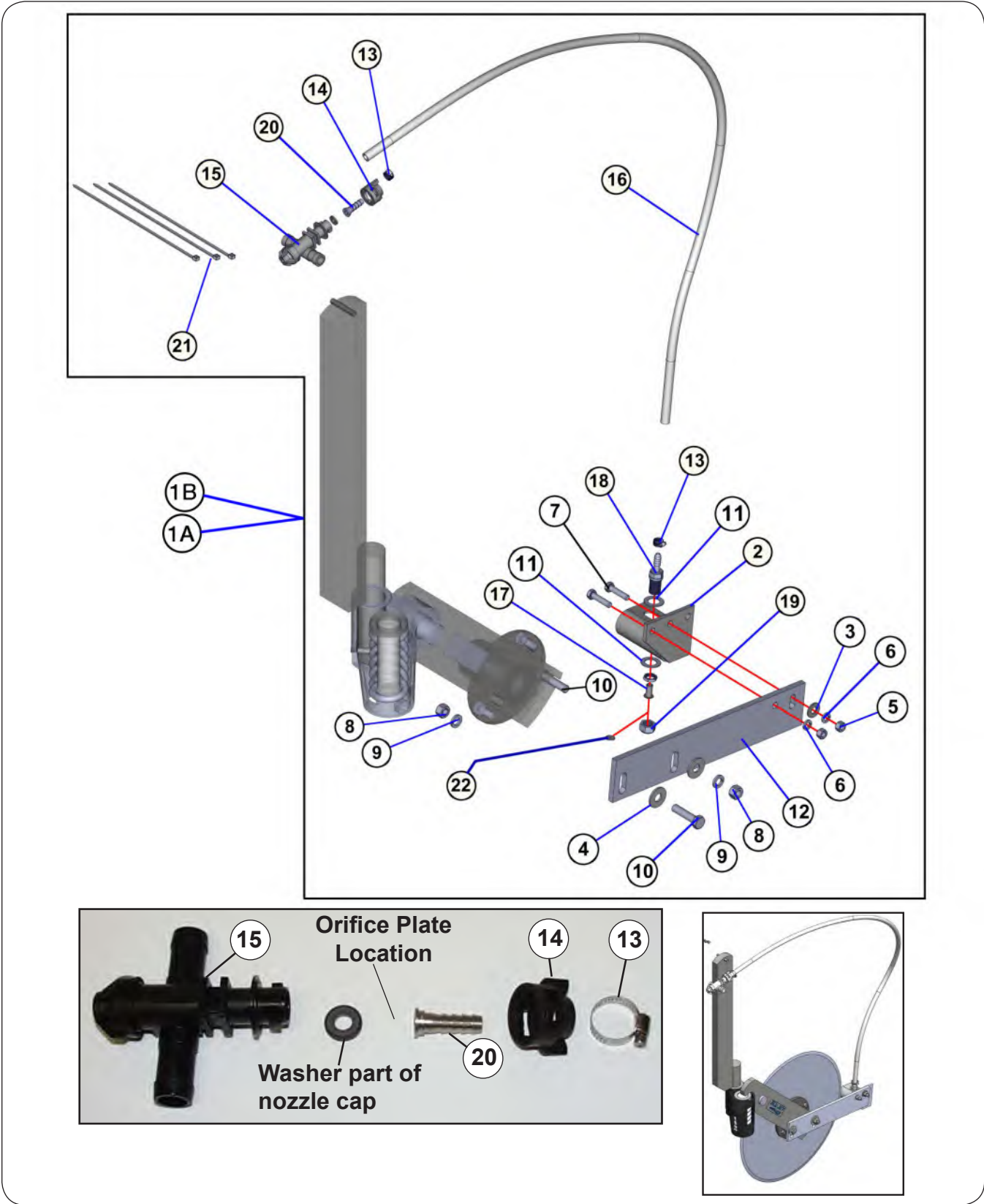

**Jetstream Liquid Assembly Components
Tee-Jet Check (JAAM3353); Low Rate (JAAM3355)**

Please visit www.unverferth.com/parts/ for the most current parts listing.

ITEM	PART NUMBER	DESCRIPTION	QTY	NOTES
1A	JAAM3353	Jetstream Liquid Assembly Tee-Jet Check, 1 Row	1	Includes Items 2-24 & 30-31
1B	JAAM3355	Jetstream Liquid Assembly, LOW RATE	1	Includes Items 2-29
2	JAM3627	Nozzle Mount, Jetstream, AT3000/ AT4000/ AT4600	1	
3	9405-076	Flat Washer, 3/8" USS	1	
4	9405-088	Flat Washer, 1/2" USS	2	
5	900901-006	Hex Nut, 3/8"-16UNC (Stainless Steel)	2	
6	900903-021	Lock Washer, 3/8" (Stainless Steel)	2	
7	900900-057	Capscrew, 3/8"-16UNC x 1 1/2" (Stainless Steel)	2	
8	900901-010	Hex Nut, 1/2"-13UNC, (Stainless Steel)	2	
9	900903-025	Lock Washer, 1/2" (Stainless Steel)	2	
10	900900-103	Capscrew, 1/2"-13UNC x 2" (Stainless Steel)	2	
11	JBP3461	Flat Washer, 5/8" (Stainless Steel)	2	
12	JCM2305	Jetstream Mounting Arm	1	
13	TA800902	Hose Clamp, Worm Gear, 1/4" - 5/8" Tubing	2	Stainless Steel
14	TA881008	Nozzle Cap, 25608-1-NYR	1	
15	TA886025	Diaphragm Check Valve, Double Shank, 3/4 Hose	1	
16	TA806200	Hose, EVA, N 3/8" Braid Jetstream	1	
17	JCP2537	Stream Stabilizer-Stainless Steel Jetstream	1	
18	JCP2578	Nozzle BODY, Straight With Nut, 3/8" Hose	1	Stainless Steel
19	JCP2589	Nozzle Cap, Stainless Steel	1	
20	JCP5046	Hose Barb Insert, 3/8", Stainless Steel	1	
21	9003735	Cable Tie 11-3/8" Standard	3	
22	TA862032	Orifice Plate #4916-63 Jetstream	1	
	TA862036	Orifice Plate #4916-70 Jetstream		
	JCP2543	Orifice Plate #4916-78 Jetstream		
	JCP2559	Orifice Plate #4916-30 Jetstream		
	JCP2557	Orifice Plate #4916-35 Jetstream		
	TA862017	Orifice Plate #4916-40 Jetstream		
	TA862024	Orifice Plate #4916-49 Jetstream		
	TA862029	Orifice Plate #4916-57 Jetstream		
	JCP2544	Orifice Plate #4916-86 Jetstream		
JCP2545	Orifice Plate #4916-95 Jetstream			

AT4615 — Parts

Lighting Components — For 15", 20", & 30" Spacing

Please visit www.unverferth.com/parts/ for the most current parts listing.

- 15 ROW/30" - 37.5' TOOLBAR
- 17 ROW/30" - 42.5' TOOLBAR
- 23 ROW/30" - 57.5' TOOLBAR
- 25 ROW/20" - 42.5' TOOLBAR
- 25 ROW/30" - 62.5' TOOLBAR
- 33 ROW/15" - 41.25' TOOLBAR
- 35 ROW/20" - 58.33' TOOLBAR

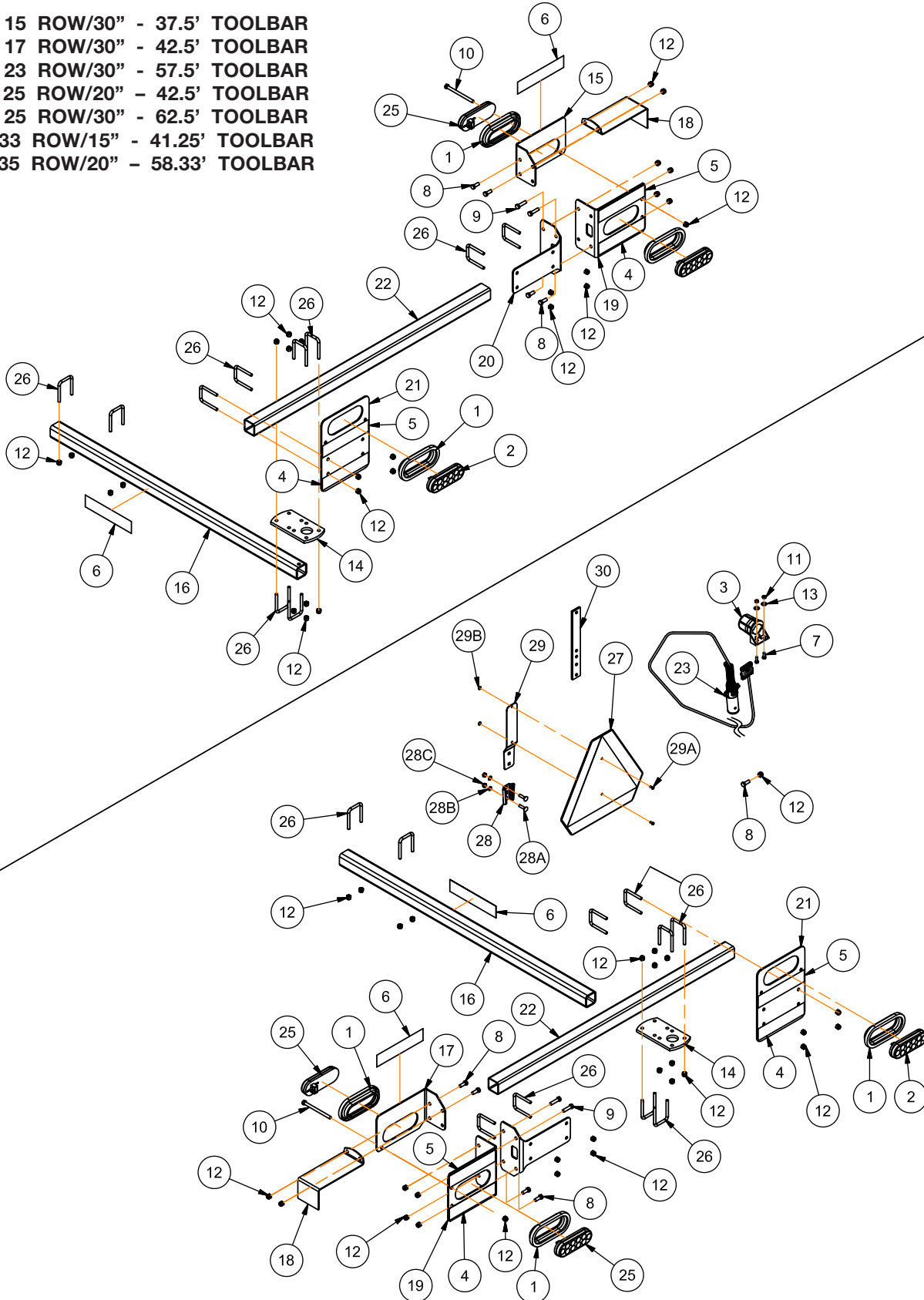

AT4615 — Parts

Lighting Components — For 15", 20", & 30" Spacing

Please visit www.unverferth.com/parts/ for the most current parts listing.

ITEM	PART NUMBER	DESCRIPTION	QTY	NOTES
	J41000050	Lighting Kit	-	Includes Items 1-29
1	97182	Grommet for Panel Light	6	
2	902217	Light/RED LED, 10 Diode, 3 Prong Panel Mount	2	
3	9001968	Connector Holder	1	
4	9003125	Fluorescent Strip (2" x 9")	4	
5	9003126	Reflector, RED (2" x 9")	4	
6	9003127	Reflector, AMBER (2" x 9")	4	
7	9390-003	Capscrew, 1/4"-20UNC x 3/4" G5	2	
8	9390-055	Capscrew, 3/8"-16UNC x 1" G5	9	
9	9390-057	Capscrew, 3/8"-16UNC x 1 1/2" G5	4	
10	9390-069	Capscrew, 3/8"-16UNC x 5" G5	2	
11	9394-002	Hex Nut, 1/4"-20UNC	2	
12	9398-012	Elastic Lock Nut, 3/8"-16UNC	55	
13	9405-064	Flat Washer, 1/4" USS	2	
14	JAM3410	Light Post Mounting Plate	2	
15	JAM3415	Front, Left-Hand Light Bracket	1	
16	JAM3416	Tube Light Bracket, 48"	2	
17	JAM3417	Front, Right-Hand Light Bracket	1	
18	JAM3418	Light Bracket Shield	2	
19	JAM3421	Side Mount Light Bracket	2	
20	JAM3422	Side Mount Light Bracket	2	
21	JAM3429	Light Mount	2	
22	JAM3432	Light Bracket, 2" x 2" x 46"	2	
23	JAP3142	Wire Harness 10' Main (7-Pin)	1	
24	JAP3197	Wire Harness 17' (2-Pin)	1	
25	JAP4415	Light/AMBER LED	4	
26	JBP3736	U-Bolt, 3/8"-16UNC x 2"W x 3"L G5	20	
27	TA510514	SMV Emblem	1	
28	TA510515	SMV Socket Bracket	1	
28A	9388-026	Carriage Bolt, 5/16"-18UNC x 1 1/4" G5	2	
28B	9404-019	Lock Washer, 5/16"	2	
28C	9394-004	Hex Nut, 5/16"-18UNC	2	
29	TA510516	SMV Spade Mounting with Hardware	1	Includes Items 29A & 29B
29A	903172-133	Pan Head Screw, #10-24UNC x 1/2"	2	
29B	9830-017	Hex Nut, #10-24UNC	2	
30	JAM4422	SMV Mounting Bracket	1	

Lighting Components — For 18" Spacing

Please visit www.unverferth.com/parts/ for the most current parts listing.

27 ROW/18" - 40.5' TOOLBAR

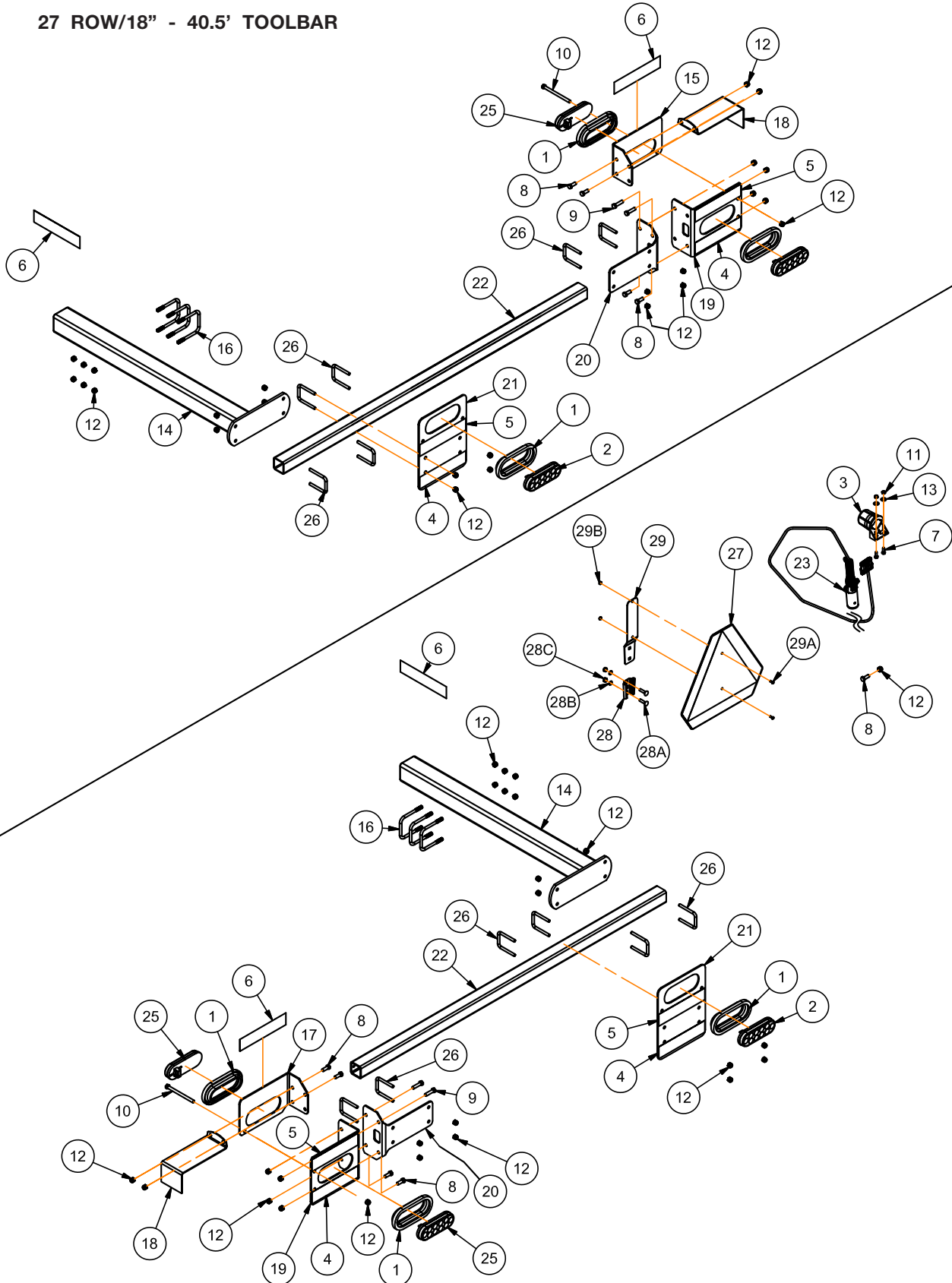

AT4615 — Parts

Lighting Components — For 18" Spacing

Please visit www.unverferth.com/parts/ for the most current parts listing.

ITEM	PART NUMBER	DESCRIPTION	QTY	NOTES
	J41000049	Lighting Kit	-	Includes Items 1-29
1	97182	Grommet for Panel Light	6	
2	902217	Light/RED LED, 10 Diode, 3 Prong Panel Mount	2	
3	9001968	Connector Holder	1	
4	9003125	Fluorescent Strip (2" x 9")	4	
5	9003126	Reflector, RED (2" x 9")	4	
6	9003127	Reflector, AMBER (2" x 9")	4	
7	9390-003	Capscrew, 1/4"-20UNC x 3/4" G5	2	
8	9390-055	Capscrew, 3/8"-16UNC x 1" G5	9	
9	9390-057	Capscrew, 3/8"-16UNC x 1 1/2" G5	4	
10	9390-069	Capscrew, 3/8"-16UNC x 5" G5	2	
11	9394-002	Hex Nut, 1/4"-20UNC	2	
12	9398-012	Elastic Lock Nut, 3/8"-16UNC	51	
13	9405-064	Flat Washer, 1/4" USS	2	
14	JAM3434	Light Bracket, Narrow Wheel Spacing	2	
15	JAM3415	Front, Left-Hand Light Bracket	1	
16	JBP3362	U-Bolt, 3/8"-16UNC x 4", 3 7/16" C/C G5	6	
17	JAM3417	Front, Right-Hand Light Bracket	1	
18	JAM3418	Light Bracket Shield	2	
19	JAM3421	Side Mount Light Bracket	2	
20	JAM3422	Side Mount Light Bracket	2	
21	JAM3429	Light Mount	2	
22	JAM3433	Light Bracket, 2" x 2" x 59 3/4"	2	
23	JAP3142	Wire Harness 10' Main (7-Pin)	1	
24	JAP3197	Wire Harness 17' (2-Pin)	1	
25	JAP4415	Light/AMBER LED	4	
26	JBP3736	U-Bolt, 3/8"-16UNC x 2"W x 3"L G5	12	
27	TA510514	SMV Emblem	1	
28	TA510515	SMV Socket Bracket	1	
28A	9388-026	Carriage Bolt, 5/16"-18UNC x 1 1/4" G5	2	
28B	9404-019	Lock Washer, 5/16"	2	
28C	9394-004	Hex Nut, 5/16"-18UNC	2	
29	TA510516	SMV Spade Mounting with Hardware	1	
29A	903172-133	Pan Head Screw, #10-24UNC x 1/2"	2	
29B	9830-017	Hex Nut, #10-24UNC	2	

Hitch Hydraulic Components (Double Tube Toolbar)

Please visit www.unverferth.com/parts/ for the most current parts listing.

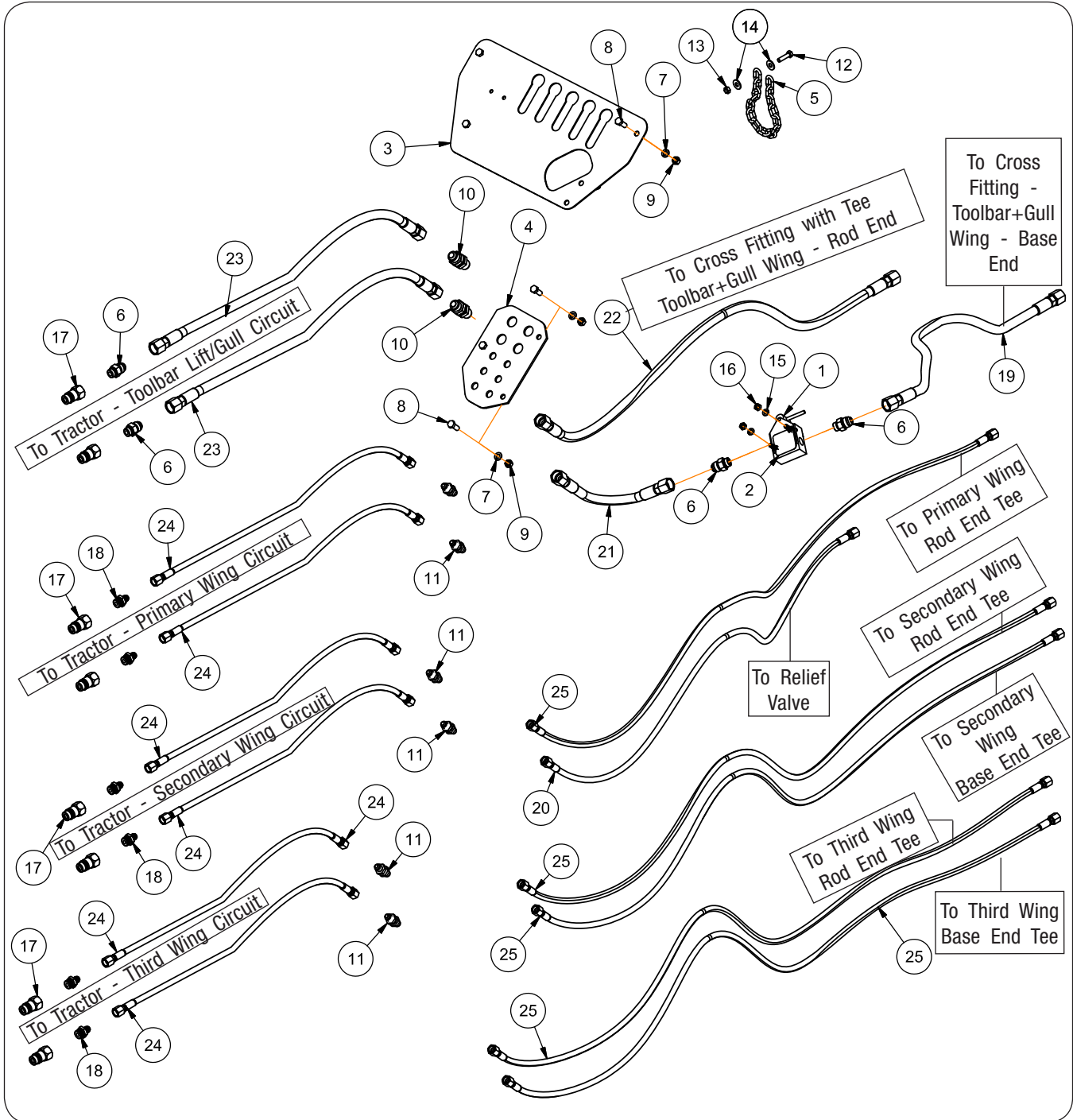

Hitch Hydraulic Components (Double Tube Toolbar)

Please visit www.unverferth.com/parts/ for the most current parts listing.

ITEM	PART NUMBER	DESCRIPTION	QTY	NOTES
1	JDP3993	Hydraulic Check Valve w/Manual Release	1	
2	JAP2481	Decal, Transport Lock	1	
3	JAM3691	Utility Plate	1	
4	JAM3690	Bulkhead Plate	1	
5	96589	Chain, 3/16" Proof Coil	1	
6	9503026	Adapter, 7/8-14 JIC Male x 3/4-16 O-Ring Male	12	
7	9404-021	Lock Washer, 3/8"	12	
8	9390-055	Capscrew, 3/8"-16UNC x 1" G5	6	
9	9394-006	Hex Nut, 3/8"-16UNC	12	
10	9005789	Bulkhead Union, 7/8-14 JIC Male x 7/8-14 JIC Male	2	
11	95192	Bulkhead Union, 9/16-18 JIC Male x 9/16-18 JIC Male	6	
12	9390-031	Capscrew, 5/16"-18UNC x 1 1/4" G5	2	
13	9807	Lock Nut, 5/16"-18UNC	2	
14	9405-070	Flat Washer, 5/16" USS	6	
15	9404-019	Lock Washer, 5/16"	2	
16	9394-004	Hex Nut, 5/16"-18UNC	2	
17	91383	Male Tip Coupling, 3/4"-16	8	
18	92927	Adapter, 9/16-18 JIC Male x 3/4-16 O-Ring Male	7	
19	JDP5210	Hydraulic Hose, 1/2" Dia. x 48" (7/8-14 JIC Female x 7/8-14 JIC Female)	1	To Cross Fitting - Toolbar+Gull Wing - Base End
20	JDP5263	Hydraulic Hose, 1/4" Dia. x 54" (9/16-18 JIC Female x 9/16-18 JIC Female)	1	To Relief Valve Inlet
21	JDP5131	Hydraulic Hose, 1/2" Dia. x 24" (7/8-14 JIC Female x 7/8-14 JIC Female)	1	To Hydraulic Check Valve
22	JDP5194	Hydraulic Hose, 1/2" Dia. x 58" (7/8-14 JIC Female x 7/8-14 JIC Female)	1	To Cross Fitting - Toolbar+Gull Wing - Rod End
23	JDP5185	Hydraulic Hose, 1/2" Dia. x 84" (7/8-14 JIC Female x 7/8-14 JIC Female)	2	To Tractor - Toolbar Lift/Gull Circuit
24	JDP5152	Hydraulic Hose, 1/4" Dia. x 84" (9/16-18 JIC Female x 9/16-18 JIC Female)	6	To Tractor - Primary Wing Circuit; To Tractor - Secondary Wing Circuit; To Tractor - Third Wing Circuit
25	JDP5043	Hydraulic Hose, 1/4" Dia. x 72" (9/16-18 JIC Female x 9/16-18 JIC Female)	5	To Primary Wing - Rod End Tee; To Secondary Wing - Rod End Tee; To Secondary Wing - Base End Tee; To Third Wing - Rod End Tee; To Third Wing - Base End Tee

Hitch Hydraulic Components (Single Tube Toolbar)

Please visit www.unverferth.com/parts/ for the most current parts listing.

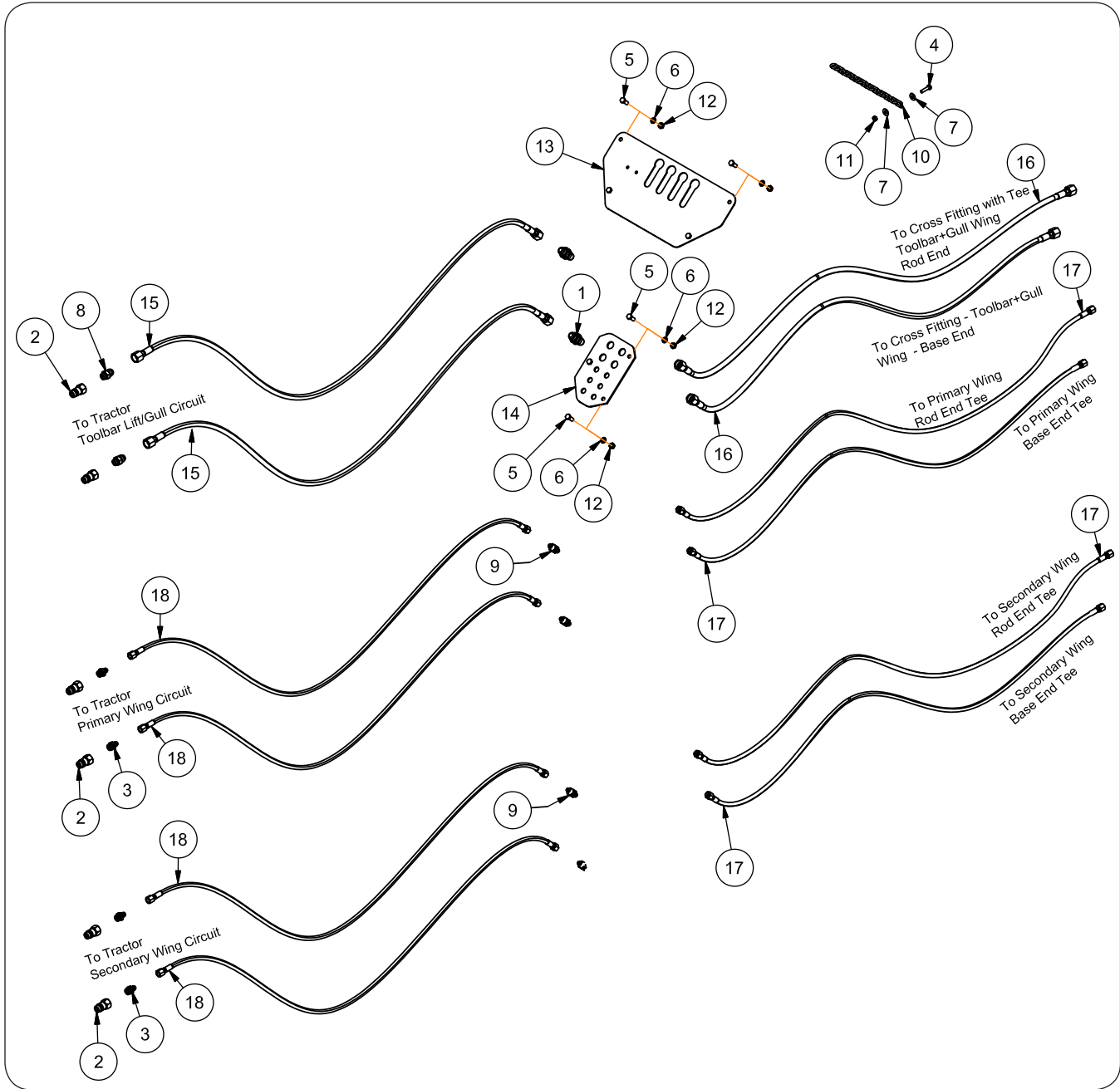

Hitch Hydraulic Components (Single Tube Toolbar)

Please visit www.unverferth.com/parts/ for the most current parts listing.

ITEM	PART NUMBER	DESCRIPTION	QTY	NOTES
1	9005789	Bulkhead Union, 7/8-14 JIC Male x 7/8-14 JIC Male	2	
2	91383	Male Tip Coupling, 3/4"-16	4	
3	92927	Adapter, 9/16-18 JIC Male x 3/4-16 O-Ring Male	4	
4	9390-031	Capscrew, 5/16"-18UNC x 1 1/4" G5	2	
5	9390-055	Capscrew, 3/8"-16UNC x 1" G5	7	
6	9404-021	Lock Washer, 3/8"	7	
7	9405-070	Flat Washer, 5/16" USS	4	
8	9503026	Adapter, 7/8-14 JIC Male x 3/4-16 O-Ring Male	6	
9	95192	Bulkhead Union, 9/16-18 JIC Male x 9/16-18 JIC Male	4	
10	96589	Chain, 3/16" Proof Coil	1	
11	9807	Lock Nut, 5/16"-18UNC	2	
12	9928	Lock Nut/Top, 3/8"-16UNC	7	
13	JAM3589	Utility Plate	1	
14	JAM3690	Bulkhead Plate	1	
15	JDP5007	Hydraulic Hose, 3/8" Dia. x 84" (7/8-14 JIC Female x 7/8-14 JIC Female)	2	To Tractor - Toolbar Lift/Gull Circuit
16	JDP5013	Hydraulic Hose, 3/8" Dia. x 72" (7/8-14 JIC Female x 7/8-14 JIC Female)	2	To Cross Fitting - Toolbar+Gull Wing - Rod End; To Cross Fitting - Toolbar+Gull Wing - Base End;
17	JDP5043	Hydraulic Hose, 1/4" Dia. x 72" (9/16-18 JIC Female x 9/16-18 JIC Female)	4	To Primary Wing - Rod End Tee; To Relief Valve Inlet To Secondary Wing - Rod End Tee; To Secondary Wing - Base End Tee
18	JDP5152	Hydraulic Hose, 1/4" Dia. x 84" (9/16-18 JIC Female x 9/16-18 JIC Female)	4	To Tractor - Primary Wing Circuit; To Tractor - Secondary Wing Circuit;

Double Tube Toolbar Gull Wing & Relief Valve Hydraulic Components

Please visit www.unverferth.com/parts/ for the most current parts listing.

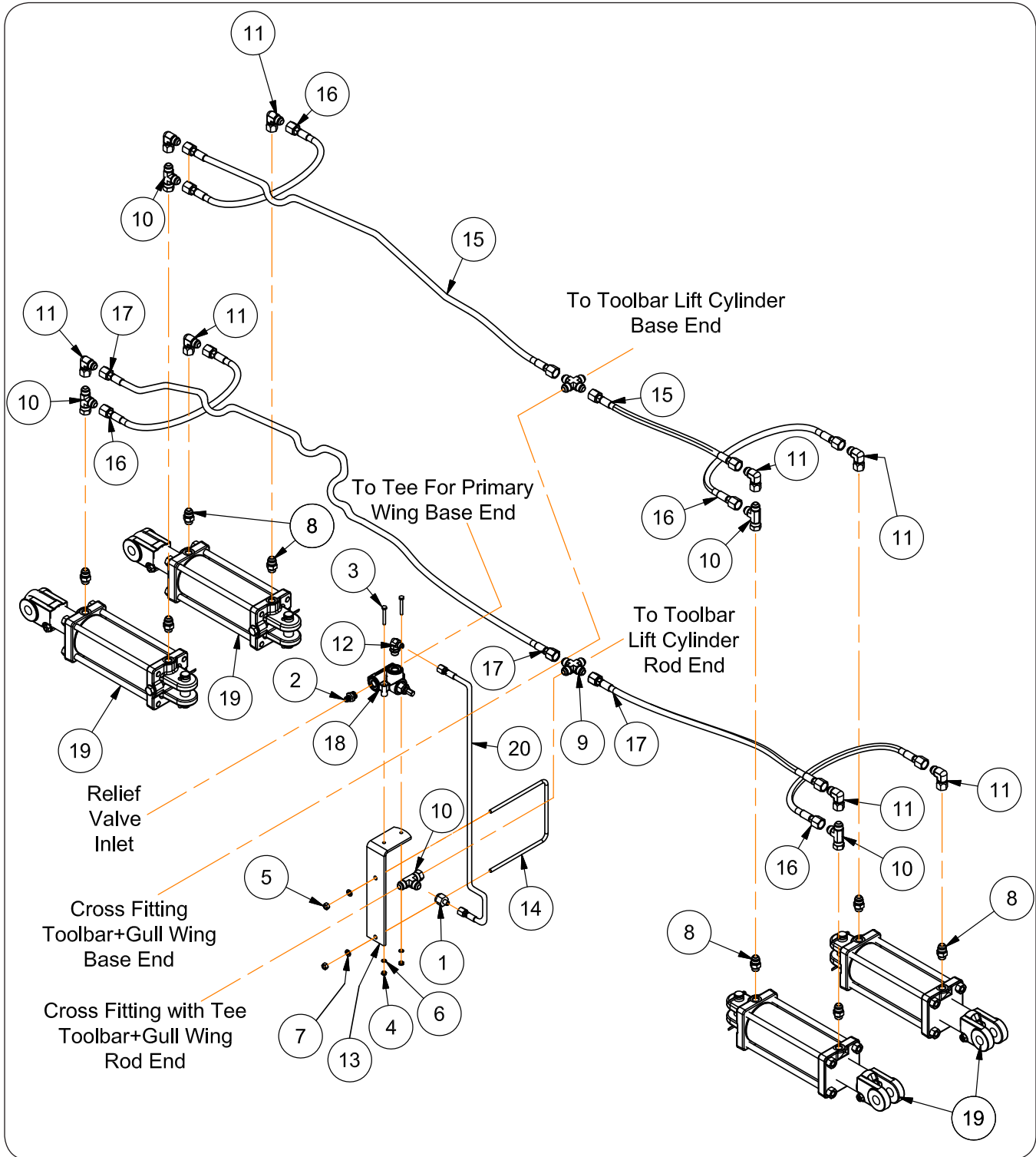

**Double Tube Toolbar Gull Wing & Relief Valve
Hydraulic Components**

Please visit www.unverferth.com/parts/ for the most current parts listing.

ITEM	PART NUMBER	DESCRIPTION	QTY
1	901102	Reducer Adapter 7/8-14 JIC Female x 9/16-18 JIC Male	1
2	92927	Adapter, 9/16-18 JIC Male x 3/4-16 O-Ring Male	7
3	9390-009	Capscrew, 1/4"-20UNC x 2" G5	2
4	9394-002	Hex Nut, 1/4"-20UNC	2
5	9394-006	Hex Nut, 3/8"-16UNC	12
6	9404-017	Lock Washer, 1/4"	2
7	9404-021	Lock Washer, 3/8"	12
8	9503026	Adapter, 7/8-14 JIC Male x 3/4-16 O-Ring Male	12
9	9503036	Cross, 7/8-14 JIC Male x 7/8-14 JIC Male x 7/8-14 JIC Male x 7/8-14 JIC Male	2
10	95478	Tee, 7/8-14 JIC Male x 7/8-14 JIC Female x 7/8-14 JIC Male	5
11	96559	90° Elbow, 7/8-14 JIC Male x 7/8-14 JIC Female	8
12	9874	90° Elbow, 9/16-18 JIC Male x 3/4-16 O-Ring Male	13
13	JAM3544	Relief Valve Mounting Bracket	1
14	JBP3335	U-Bolt, 3/8"-16UNC x 8", 7 7/16" C/C G5	3
15	JDP5005	Hydraulic Hose, 3/8" Dia. x 30" (7/8-14 JIC Female x 7/8-14 JIC Female)	4
16	JDP5064	Hydraulic Hose, 3/8" Dia. x 24" (7/8-14 JIC Female x 7/8-14 JIC Female)	6
17	JDP5066	Hydraulic Hose, 3/8" Dia. x 42" (7/8-14 JIC Female x 7/8-14 JIC Female)	2
18	JDP4563	Relief Valve	1
19	JDP4490	Cylinder 4" x 8"	4
	95407	Seal Kit for 4" x 8" Cylinder	-
	JBP3497	Clevis Pin, 1" Dia. x 4"	2
	9391-045	Cotter Pin, 3/16" Dia. x 1 3/4"	4

Single Tube Toolbar Gull Wing & Relief Valve Hydraulic Components

Please visit www.unverferth.com/parts/ for the most current parts listing.

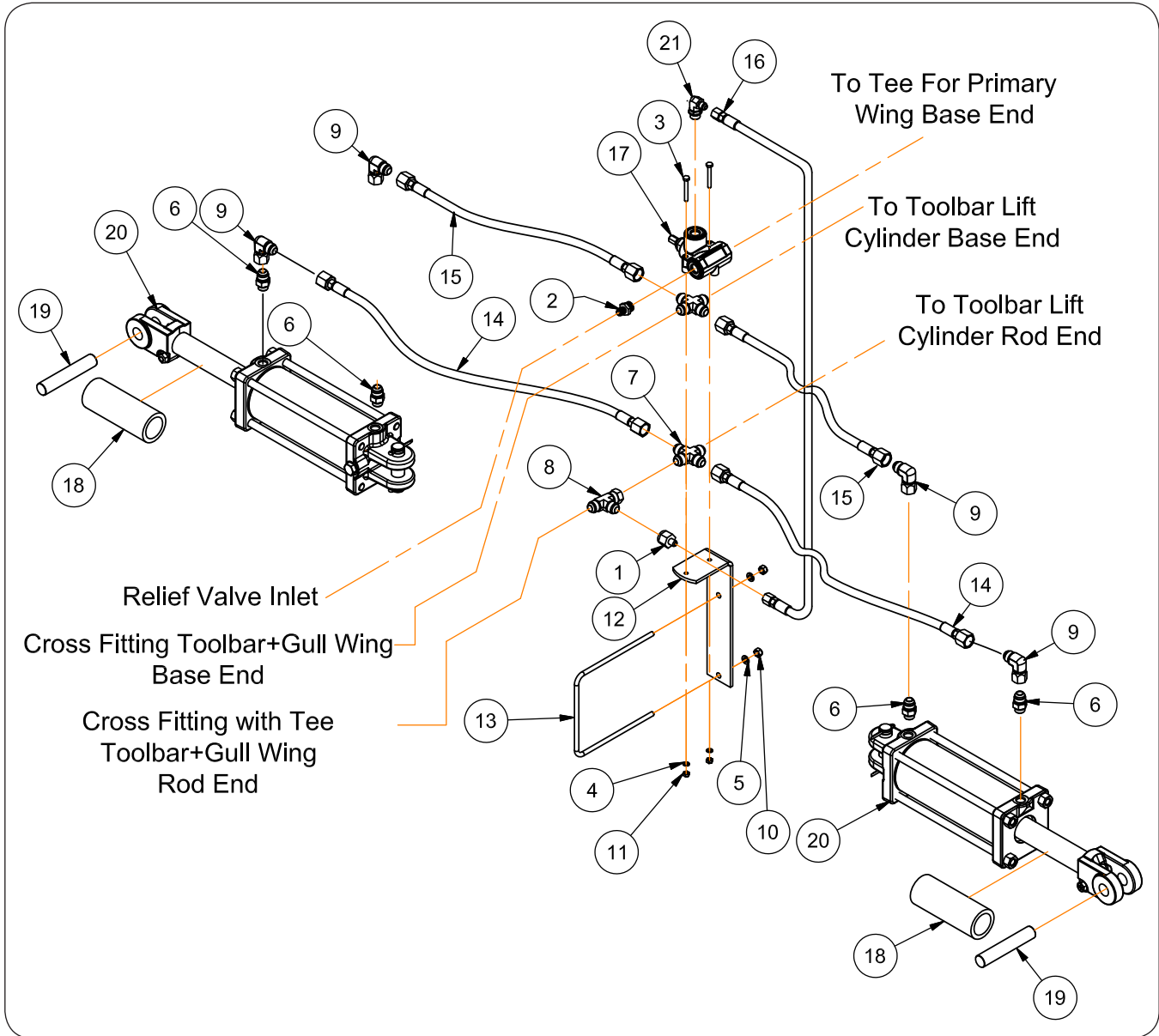

**Single Tube Toolbar Gull Wing & Relief Valve
Hydraulic Components**

Please visit www.unverferth.com/parts/ for the most current parts listing.

ITEM	PART NUMBER	DESCRIPTION	QTY
1	901102	Reducer Adapter 7/8-14 JIC Female x 9/16-18 JIC Male	1
2	92927	Adapter, 9/16-18 JIC Male x 3/4-16 O-Ring Male	1
3	9390-009	Capscrew, 1/4"-20UNC x 2" G5	2
4	9404-017	Lock Washer, 1/4"	2
5	9404-021	Lock Washer, 3/8"	2
6	9503026	Adapter, 7/8-14 JIC Male x 3/4-16 O-Ring Male	4
7	9503036	Cross, 7/8-14 JIC Male x 7/8-14 JIC Male x 7/8-14 JIC Male x 7/8-14 JIC Male	2
8	95478	Tee, 7/8-14 JIC Male x 7/8-14 JIC Female x 7/8-14 JIC Male	1
9	96559	90° Elbow, 7/8-14 JIC Male x 7/8-14 JIC Female	4
10	9928	Lock Nut/Top, 3/8"-16UNC	2
11	9936	Lock Nut/Top, 1/4"-20UNC	2
12	JAM3544	Relief Valve Mounting Bracket	1
13	JBP3335	U-Bolt, 3/8"-16UNC x 8", 7 7/16" C/C G5	1
14	JDP5028	Hydraulic Hose, 3/8" Dia. x 36" (7/8-14 JIC Female x 7/8-14 JIC Female)	2
15	JDP5064	Hydraulic Hose, 3/8" Dia. x 24" (7/8-14 JIC Female x 7/8-14 JIC Female)	2
16	JDP5266	Hydraulic Hose, 1/4" Dia. x 18" (9/16-18 JIC Female x 9/16-18 JIC Female)	1
17	JDP4563	Relief Valve	1
18	JAM3541	Bushing/Tube, 2 1/2" OD x 1.812" ID x 6 1/2"	2
19	JBM3492	Pin, 1" Dia. x 5 1/2"	2
20	JDP4490	Cylinder 4" x 8"	2
	95407	Seal Kit for 4" x 8" Cylinder	-
	JBP3497	Clevis Pin, 1" Dia. x 4"	2
	9391-045	Cotter Pin, 3/16" Dia. x 1 3/4"	4
21	9874	90° Elbow, 9/16-18 JIC Male x 3/4-16 O-Ring Male	1

**Primary Wing Hydraulic Components
(Double Tube Toolbar)**

Please visit www.unverferth.com/parts/ for the most current parts listing.

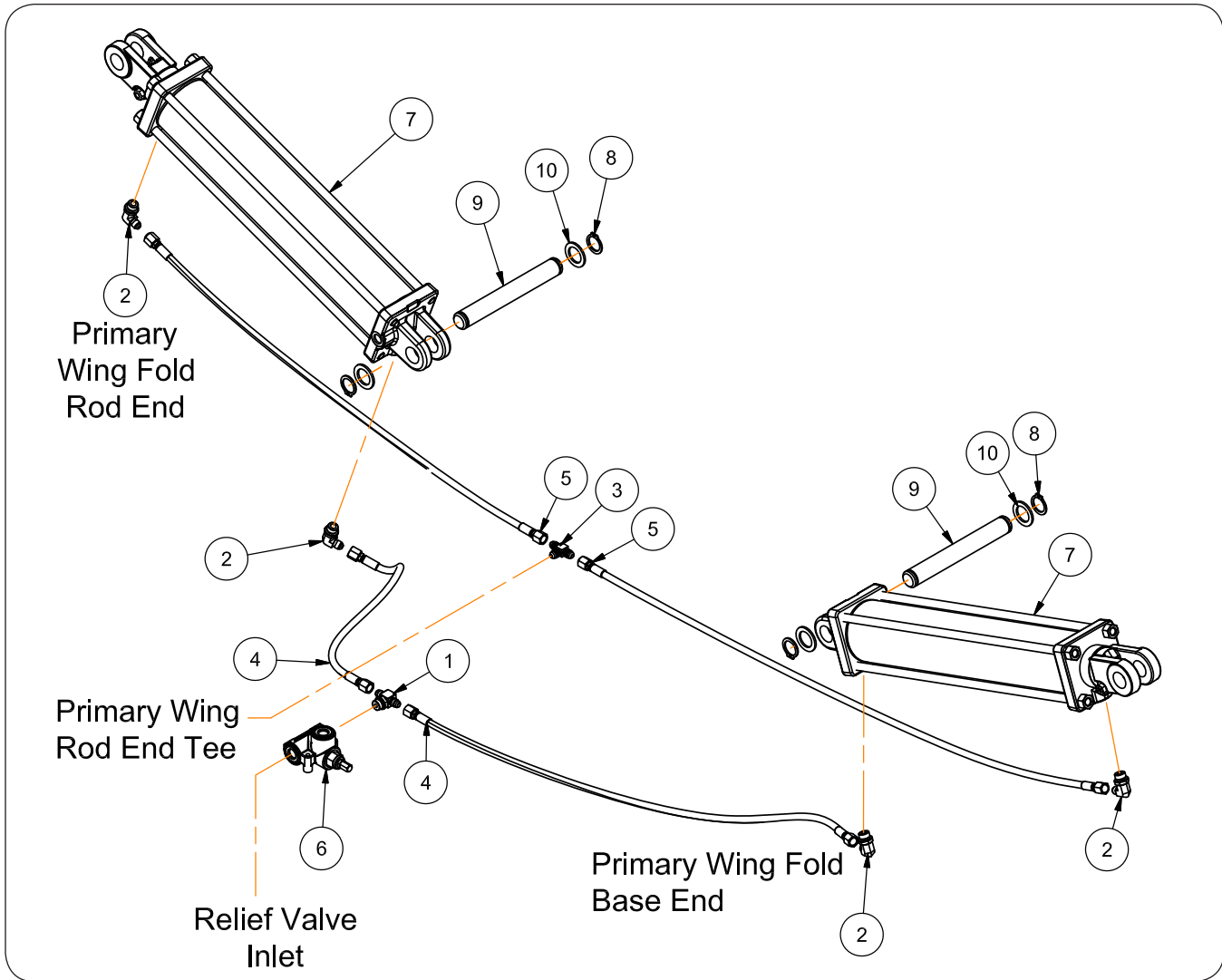

ITEM	PART NUMBER	DESCRIPTION	QTY
1	9002274	Tee 9/16-18 JIC Male x 9/16-18 JIC Male x 3/4-16 O-Ring Male	1
2	9874	90° Elbow, 9/16-18 JIC Male x 3/4-16 O-Ring Male	4
3	9875	Tee, 9/16-18 JIC Male x 9/16-18 JIC Male x 9/16-18 JIC Male	1
4	JDP5057	Hydraulic Hose, 1/4" Dia. x 36" (9/16-18 JIC Female x 9/16-18 JIC Female)	2
5	JDP5263	Hydraulic Hose, 1/4" Dia. x 54" (9/16-18 JIC Female x 9/16-18 JIC Female)	2
6	JDP4563	Relief Valve	1
7	JDP4762-1	Cylinder 4" x 20" w/Spacer	2
	JEM7411	Spacer/Tube	-
	95407	Seal Kit for 4" x 8" Cylinder	-
	JBP3498	Clevis Pin, 1 1/4" Dia. x 4"	2
	9391-045	Cotter Pin, 3/16" Dia. x 1 3/4"	4
8	JAP2711	Snap Ring 1 1/4", External Heavy-Duty	2
9	JBM3544	Pin, 1 1/4" Dia. x 9.78"	4
10	JBP3192	Machinery Bushing, 1 7/8" OD x 1/4" ID	4

Primary Wing Hydraulic Components (Single Tube Toolbar)

Please visit www.unverferth.com/parts/ for the most current parts listing.

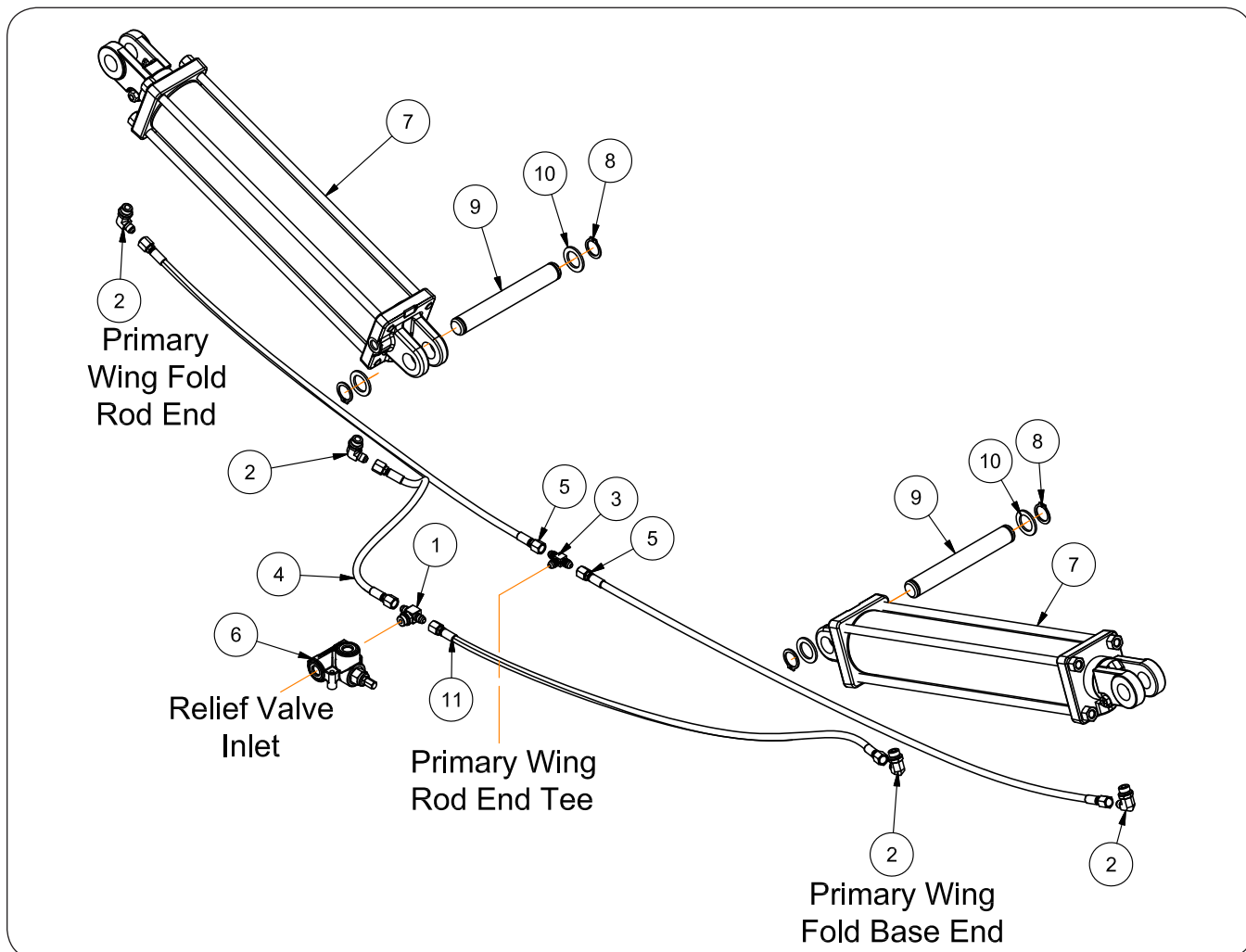

ITEM	PART NUMBER	DESCRIPTION	QTY
1	9002274	Tee 9/16-18 JIC Male x 9/16-18 JIC Male x 3/4-16 O-Ring Male	1
2	9874	90° Elbow, 9/16-18 JIC Male x 3/4-16 O-Ring Male	4
3	9875	Tee, 9/16-18 JIC Male x 9/16-18 JIC Male x 9/16-18 JIC Male	1
4	JDP5267	Hydraulic Hose, 1/4" Dia. x 32" (9/16-18 JIC Female x 9/16-18 JIC Female)	1
5	JDP5241	Hydraulic Hose, 1/4" Dia. x 52" (9/16-18 JIC Female x 9/16-18 JIC Female)	2
6	JDP4563	Relief Valve	1
7	JDP4762-1	Cylinder 4" x 20" w/Spacer	2
	JEM7411	Spacer/Tube	-
	95407	Seal Kit for 4" x 8" Cylinder	-
	JBP3498	Clevis Pin, 1 1/4" Dia. x 4"	2
	9391-045	Cotter Pin, 3/16" Dia. x 1 3/4"	4
8	JAP2711	Snap Ring 1 1/4", External Heavy-Duty	2
9	JBM3544	Pin, 1 1/4" Dia. x 9.78"	4
10	JBP3192	Machinery Bushing, 1 7/8" OD x 1/4" ID	4
11	JDP5060	Hydraulic Hose, 1/4" Dia. x 24" (9/16-18 JIC Female x 9/16-18 JIC Female)	1

**Toolbar Lift Hydraulic Components
(Double Tube Toolbar)**

Please visit www.unverferth.com/parts/ for the most current parts listing.

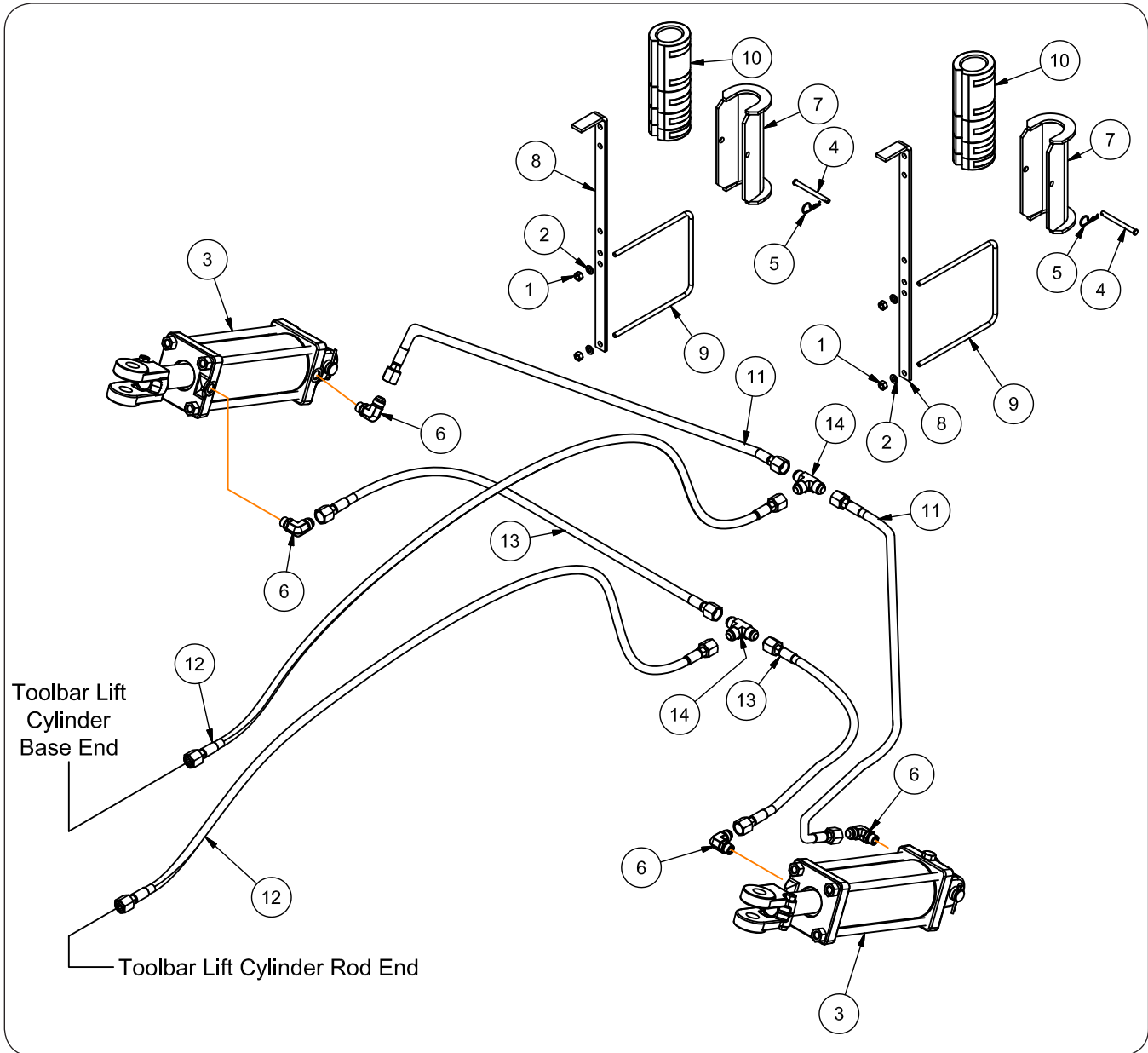

**Toolbar Lift Hydraulic Components
(Double Tube Toolbar)**

Please visit www.unverferth.com/parts/ for the most current parts listing.

ITEM	PART NUMBER	DESCRIPTION	QTY
1	9394-006	Hex Nut, 3/8"-16UNC	4
2	9404-021	Lock Washer, 3/8"	4
3	JDP4490	Cylinder 4" x 8"	2
	95407	Seal Kit for 4" x 8" Cylinder	-
	JBP3497	Clevis Pin, 1" Dia. x 4"	2
	9391-045	Cotter Pin, 3/16" Dia. x 1 3/4"	4
4	9503240	Clevis Pin, 5/16" Dia. x 3 1/2"	2
5	9514	Hairpin Cotter, 0.092" Dia. x 1 7/8"	2
6	98201	90° Elbow, 7/8-14 JIC Male x 3/4-16 O-Ring Male	4
7	JAM4721	Transport Cylinder Lock Weldment	2
8	JAM4817	Depth Collar Storage Bracket	2
9	JBP3335	U-Bolt, 3/8"-16UNC x 8", 7 7/16" C/C G5	2
10	JBP3433	Depth Collar Set,	2
11	JDP5005	Hydraulic Hose, 3/8" Dia. x 30" (7/8-14 JIC Female x 7/8-14 JIC Female)	2
12	JDP5013	Hydraulic Hose, 3/8" Dia. x 72" (7/8-14 JIC Female x 7/8-14 JIC Female)	2
13	JDP5064	Hydraulic Hose, 3/8" Dia. x 24" (7/8-14 JIC Female x 7/8-14 JIC Female)	2
14	JDP4023	Tee, 7/8-14 JIC Male x 7/8-14 JIC Male x 7/8-14 JIC Male	2

AT4615 — Parts

Toolbar Lift Hydraulic Components (Gull Wing Center Section w/Single Tube Frame)

Please visit www.unverferth.com/parts/ for the most current parts listing.

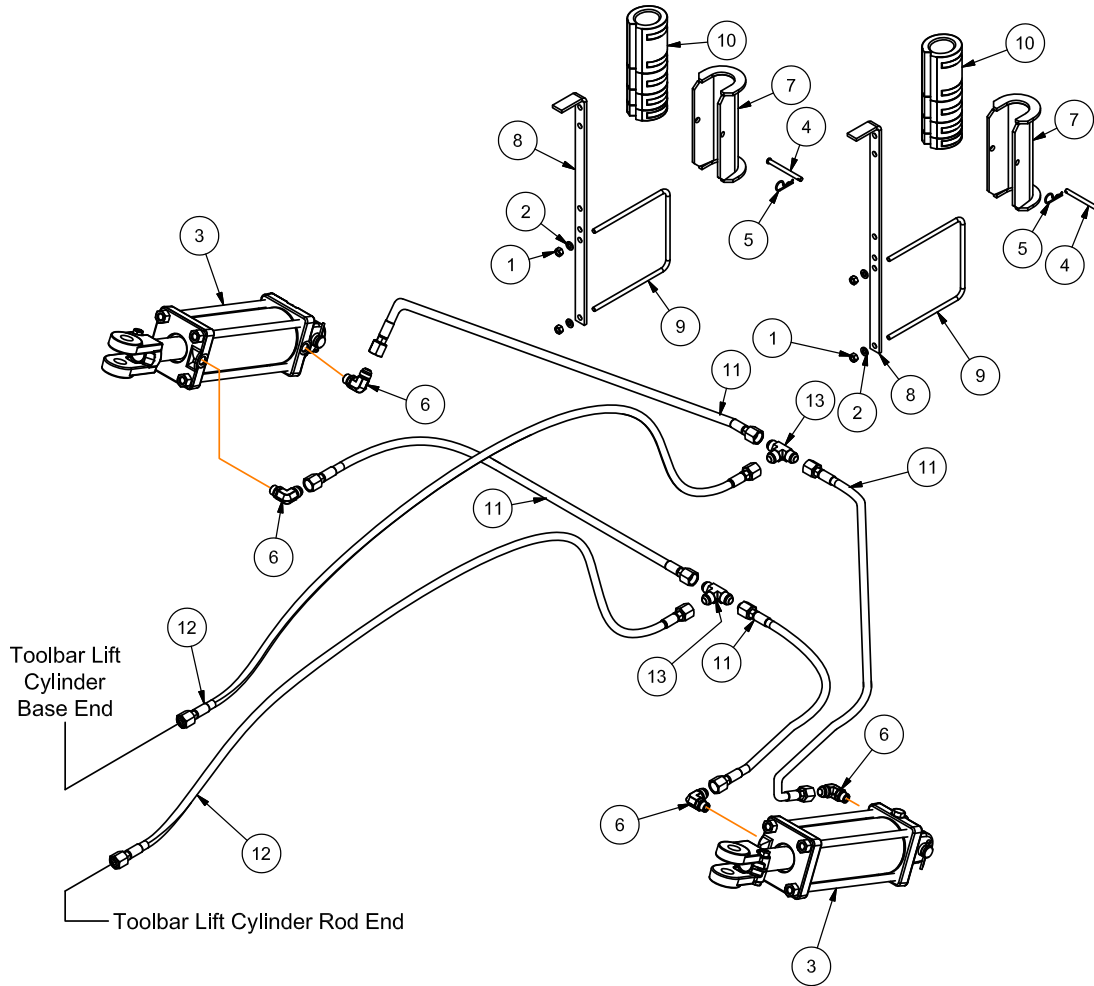

ITEM	PART NUMBER	DESCRIPTION	QTY
1	9928	Lock Nut/Top, 3/8"-16UNC	4
2	9404-021	Lock Washer, 3/8"	4
3	JDP4656	Cylinder 3" x 8"	2
	9003772	Seal Kit for 3" x 8" Cylinder	-
	JBP3403	Clevis Pin, 1" Dia. x 3 1/2"	2
	9391-045	Cotter Pin, 3/16" Dia. x 1 3/4"	4
4	9503240	Clevis Pin, 5/16" Dia. x 3 1/2"	2
5	9514	Hairpin Cotter, 0.092" Dia. x 1 7/8"	2
6	9874	90° Elbow, 9/16-18 JIC Male x 3/4-16 O-Ring Male	4
7	JAM3039	Transport Cylinder Lock Weldment	2
8	JAM4817	Depth Collar Storage Bracket	2
9	JBP3335	U-Bolt, 3/8"-16UNC x 8", 7 7/16" C/C G5	2
10	JBP3076	Depth Collar Set	2
11	JDP5111	Hydraulic Hose, 1/4" Dia. x 30" (9/16-18 JIC Female x 9/16-18 JIC Female)	4
12	JDP5255	Hydraulic Hose, 3/8" Dia. x 56" (7/8-14 JIC Female x 9/16-18 JIC Female)	2
13	9875	Tee, 9/16-18 JIC Male x 9/16-18 JIC Male x 9/16-18 JIC Male	2

**Secondary Wing Hydraulic Components
(Double Tube Toolbar)**

Please visit www.unverferth.com/parts/ for the most current parts listing.

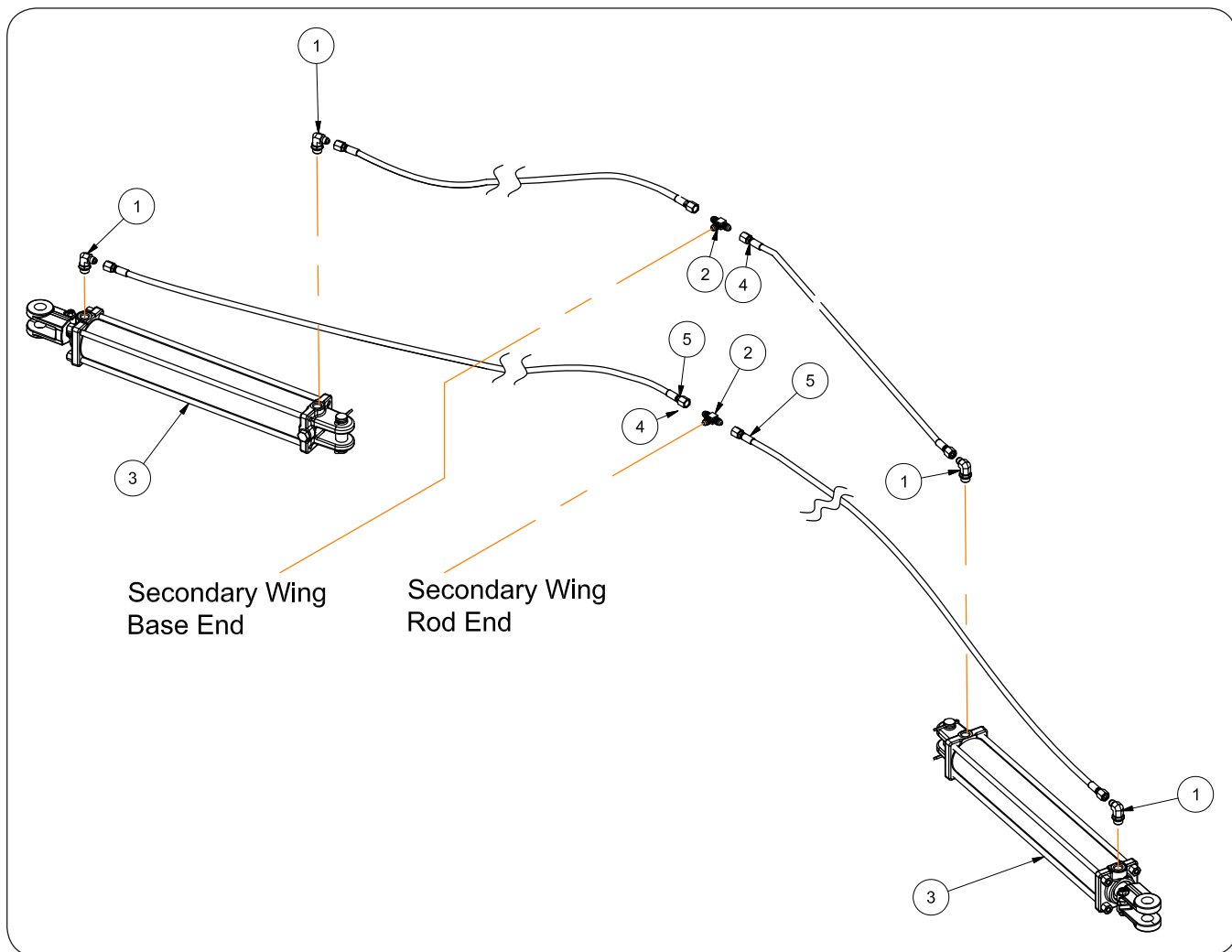

ITEM	PART NUMBER	DESCRIPTION	QTY
1	9874	90° Elbow, 9/16-18 JIC Male x 3/4-16 O-Ring Male	4
2	9875	Tee, 9/16-18 JIC Male x 9/16-18 JIC Male x 9/16-18 JIC Male	2
3	JDP4492	Cylinder 3" x 20"	2
	9003772	Seal Kit for 3" x 8" Cylinder	-
	JBP3403	Clevis Pin, 1" Dia. x 3 1/2"	2
	9391-045	Cotter Pin, 3/16" Dia. x 1 3/4"	4
4	JDP5044	Hydraulic Hose, 1/4" Dia. x 126" (9/16-18 JIC Female x 9/16-18 JIC Female)	2
5	JDP5274	Hydraulic Hose, 1/4" Dia. x 150" (9/16-18 JIC Female x 9/16-18 JIC Female)	2

**Secondary Wing Hydraulic Components
(Single Tube Toolbar)**

Please visit www.unverferth.com/parts/ for the most current parts listing.

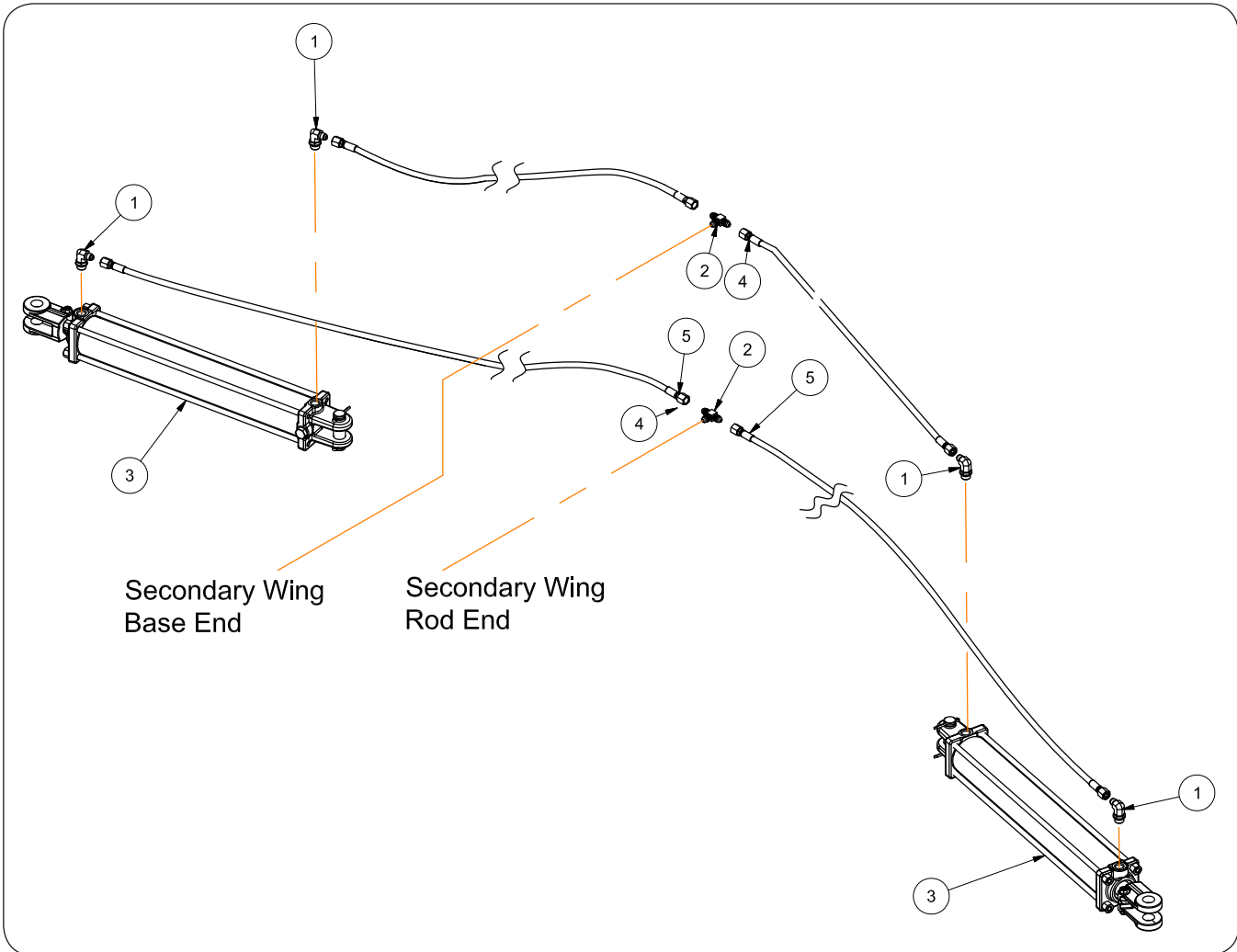

ITEM	PART NUMBER	DESCRIPTION	QTY
1	9874	90° Elbow, 9/16-18 JIC Male x 3/4-16 O-Ring Male	4
2	9875	Tee, 9/16-18 JIC Male x 9/16-18 JIC Male x 9/16-18 JIC Male	2
3	JDP4492	Cylinder 3" x 20"	2
	9003772	Seal Kit for 3" x 8" Cylinder	-
	JBP3403	Clevis Pin, 1" Dia. x 3 1/2"	2
	9391-045	Cotter Pin, 3/16" Dia. x 1 3/4"	4
4	JDP5044	Hydraulic Hose, 1/4" Dia. x 126" (9/16-18 JIC Female x 9/16-18 JIC Female)	2
5	JDP5072	Hydraulic Hose, 1/4" Dia. x 120" (9/16-18 JIC Female x 9/16-18 JIC Female)	2

AT4615 — Parts

Third Wing Hydraulic Components (Double Tube Toolbar)

Please visit www.unverferth.com/parts/ for the most current parts listing.

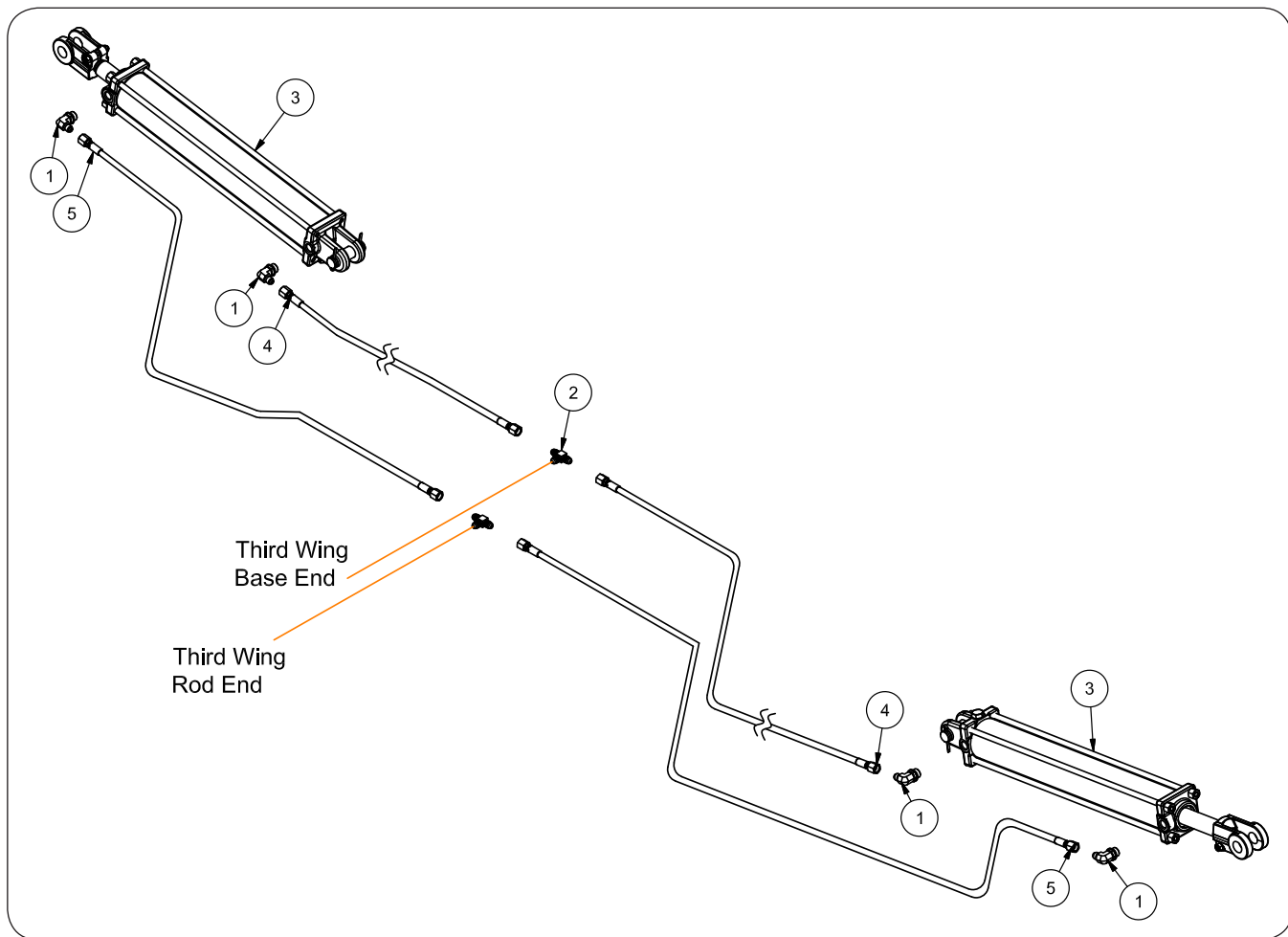

ITEM	PART NUMBER	DESCRIPTION	QTY
1	9874	90° Elbow, 9/16-18 JIC Male x 3/4-16 O-Ring Male	4
2	9875	Tee, 9/16-18 JIC Male x 9/16-18 JIC Male x 9/16-18 JIC Male	2
3	JDP4492	Cylinder 3" x 20"	2
	9003772	Seal Kit for 3" x 8" Cylinder	-
	JBP3403	Clevis Pin, 1" Dia. x 3 1/2"	2
	9391-045	Cotter Pin, 3/16" Dia. x 1 3/4"	4
4	JDP5258	Hydraulic Hose, 1/4" Dia. x 234" (9/16-18 JIC Female x 9/16-18 JIC Female)	2
5	JDP5259	Hydraulic Hose, 1/4" Dia. x 258" (9/16-18 JIC Female x 9/16-18 JIC Female)	2

Single & Double Pump Drive Components

Please visit www.unverferth.com/parts/ for the most current parts listing.

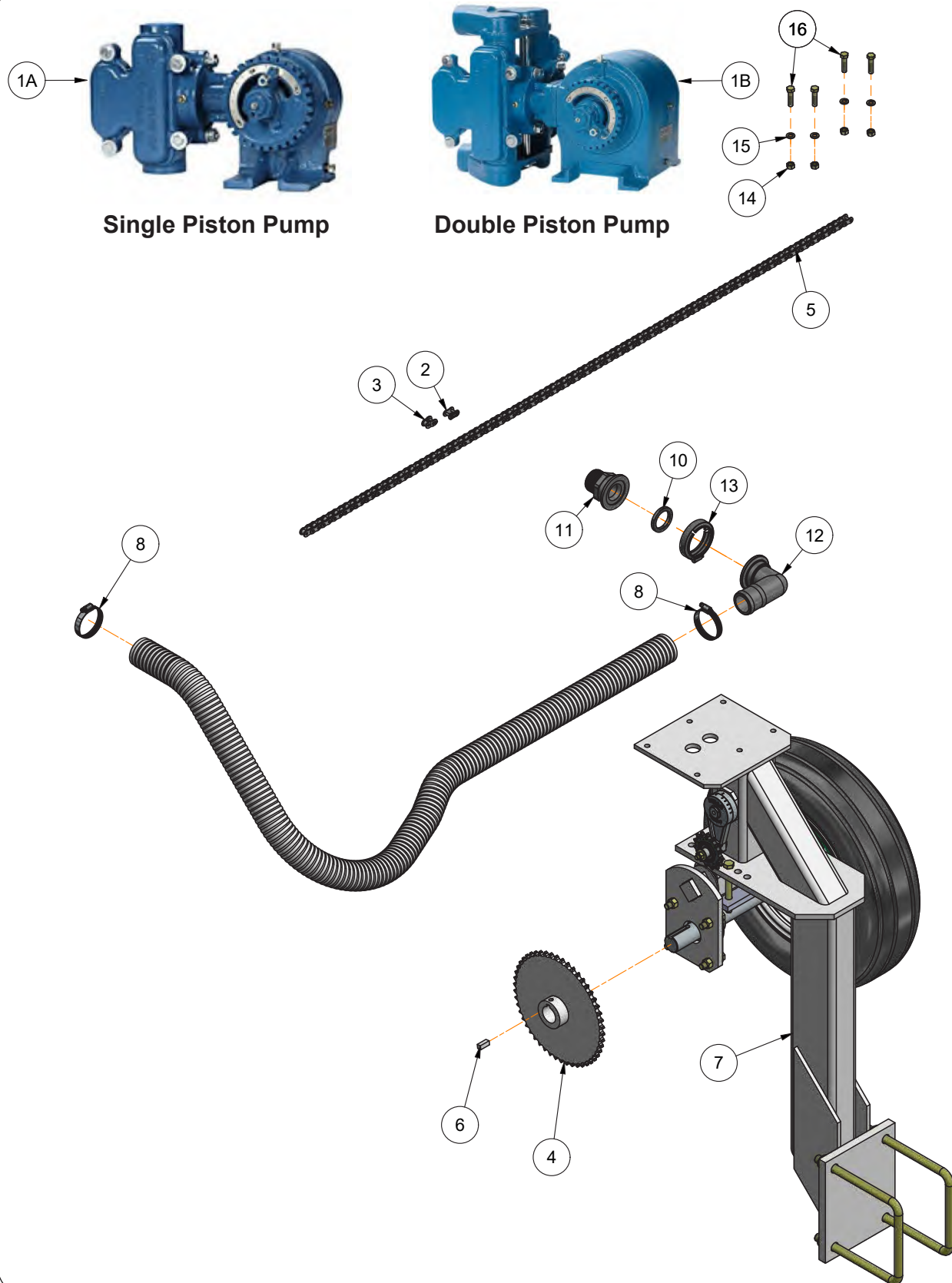

Single & Double Pump Drive Components

Please visit www.unverferth.com/parts/ for the most current parts listing.

ITEM	PART NUMBER	DESCRIPTION	QTY	NOTES
1A	JCP2568	Single Piston Pump, NGP-7055 (34.2 GPM Max)	1	
	9503890	Single Piston Pump, NGP-7055-S-BLK (34.2 GPM Max)		Stainless Steel
1B	JCP2569	Double Piston Pump, NGP-9055 (68.4 GPM Max)	1	
	9503891	Double Piston Pump, NGP-9055-S-BLK (68.4 GPM Max)		Stainless Steel
2	JAP2112	Connecting Link #50 (SS)	1	
3	JAP2113	Offset Link #50 (SS)	1	
4	JAP2392	Sprocket Weldment w/Hub 1 1/2" Bore, 3/8" Keyway, 5040X	1	
	JAP2369	Sprocket Weldment w/Hub 1 1/2" Bore, 3/8" Keyway, 5050X	1	
5	JAP2784	Roller Chain #50 (Single) 101 Links (SS)	1	
6	JBM3526	Key, 3/8" x 3/8" x 1"	1	
7	JPKG00181	Pump Drive Package	1	
8	TA800922	Worm Drive Hose Clamp (SS) (Adjusts from 3/4" to 2 5/8")	2	
9	TA806332	2" Fertilizer Solution Hose	10 FT.	
10	TA811944	Gasket, 2 3/16" OD x 1 5/8" ID x .25"	1	
11	TA815010	Adapter, 2" Flange x 1 1/2" Male NPTF	1	
12	TA815021	90° Elbow, 2" Flange x 2" Hose Barb	1	
13	TA815025	2" Worm Screw Flange Clamp	1	
14	9394-006	Hex Nut, 3/8"-16UNC	4	
15	9404-021	Lock Washer, 3/8"	4	
16	9390-057	Capscrew, 3/8"-16UNC x 1 1/2" G5	4	

AT4615 — Parts

Pump Drive Package (JPKG00181)

Please visit www.unverferth.com/parts/ for the most current parts listing.

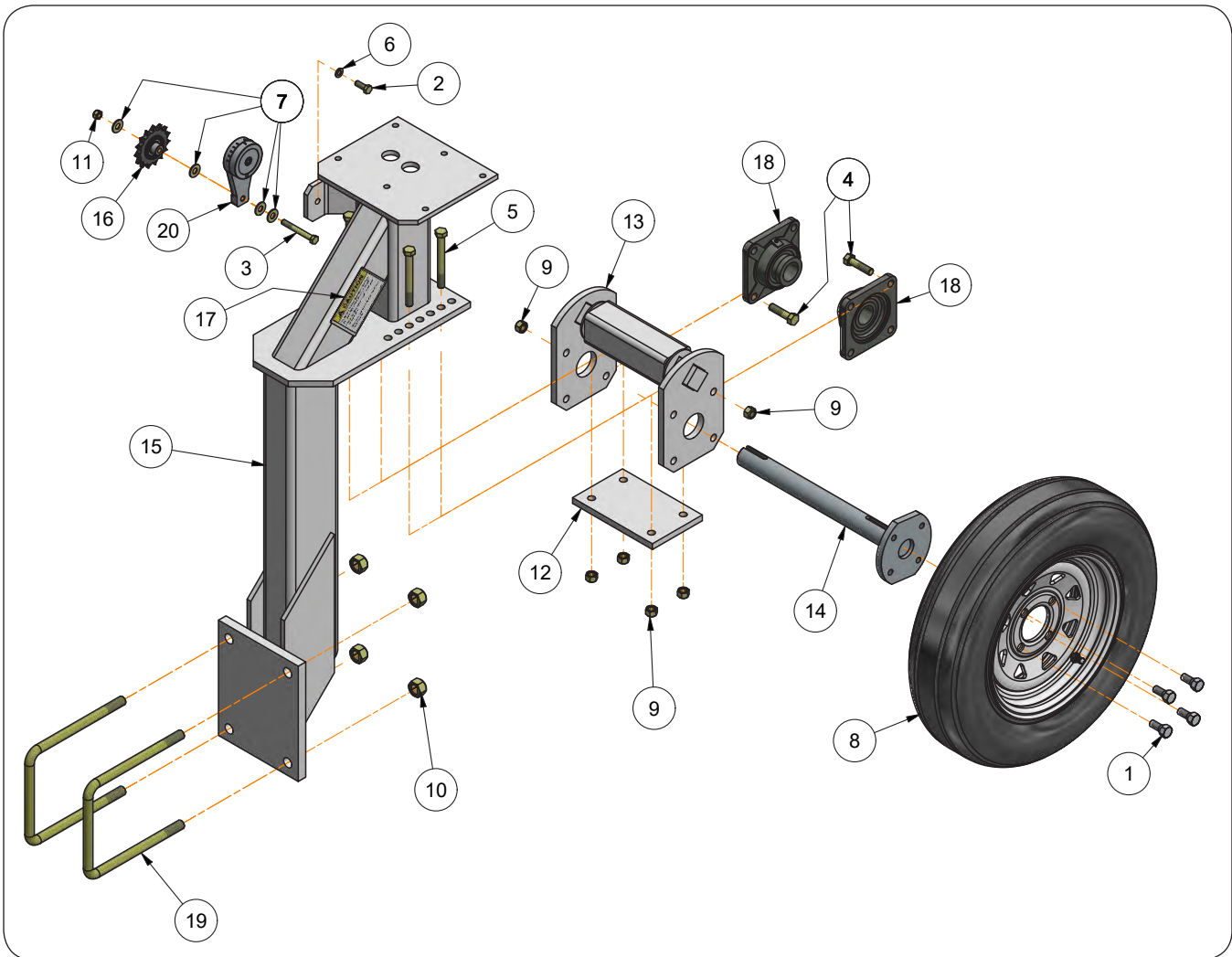

Pump Drive Package (JPKG00181)

Please visit www.unverferth.com/parts/ for the most current parts listing.

ITEM	PART NUMBER	DESCRIPTION	QTY	NOTES
1	91829	Wheel Bolt, 1/2"-20UNF x 1 5/8" G5	4	
2	9390-055	Capscrew, 3/8"-16UNC x 1" G5	1	
3	9390-063	Capscrew, 3/8"-16UNC x 3" G5	1	
4	9390-103	Capscrew, 1/2"-13UNC x 2" G5	8	
5	9390-112	Capscrew, 1/2"-13UNC x 4 1/2" G5	4	
6	9404-021	Lock Washer, 3/8"	1	
7	9405-076	Flat Washer, 3/8" USS	4	
8	9503374ACW	Wheel & Tire Assembly 4x12, ST145/12 LRD	1	
9	9800	Lock Nut/Top, 1/2"-13UNC	12	
10	9802	Lock Nut/Top, 3/4"-10UNC	4	
11	9928	Lock Nut/Top, 3/8"-16UNC	1	
12	JAM3513	Backing Plate	1	
13	JAM3515	Axle Mount Weldment Pump Drive	1	
14	JAM3516	Pump Drive Wheel Shaft Weldment	1	
15	JAM3639	Pump Mounting Weldment	1	
16	JAP2382	Idler Sprocket 15 Tooth #10 Chain w/Clevis Adapter	1	
17	JAP2472	Decal, CAUTION "To Avoid Pump Damage..."	1	
18	JAP2697	Flange Bearing 4-Bolt, 1 1/2" Bore	2	
19	JBP3058	U-Bolt, 3/4"-10UNC x 9", 7 13/16" C/C G5	2	
20	JBP3239	Rotary Tensioner	1	

40 Tooth Sprocket & Roller Chain Components

Please visit www.unverferth.com/parts/ for the most current parts listing.

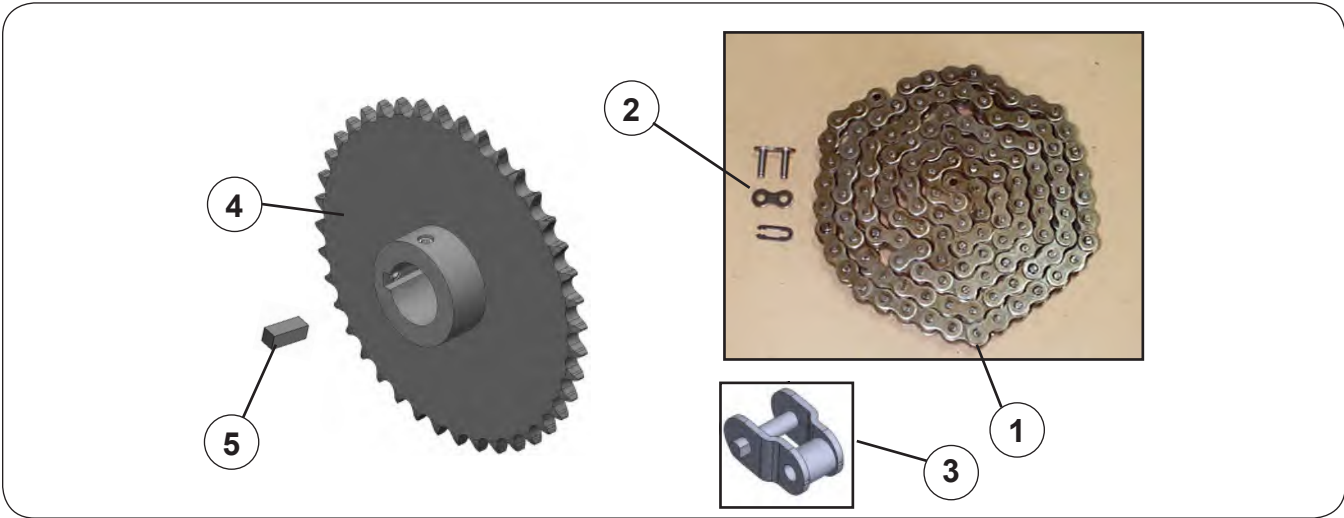

ITEM	PART NUMBER	DESCRIPTION	QTY	NOTES
1	JAP2784	Roller Chain #50 (Single) 101 Links (Stainless Steel)	1	
2	JAP2112	Connecting Link #50 (Stainless Steel)	1	
3	JAP2113	Offset Link #50 (Stainless Steel)	1	
4	JAP2392	Sprocket Weldment with Hub, 1 1/2" Bore, 3/8" Keyway, Model 5040	1	
5	JBM3526	Key, 3/8" x 3/8" x 1"	1	

50 Tooth Sprocket & Roller Chain Components

Please visit www.unverferth.com/parts/ for the most current parts listing.

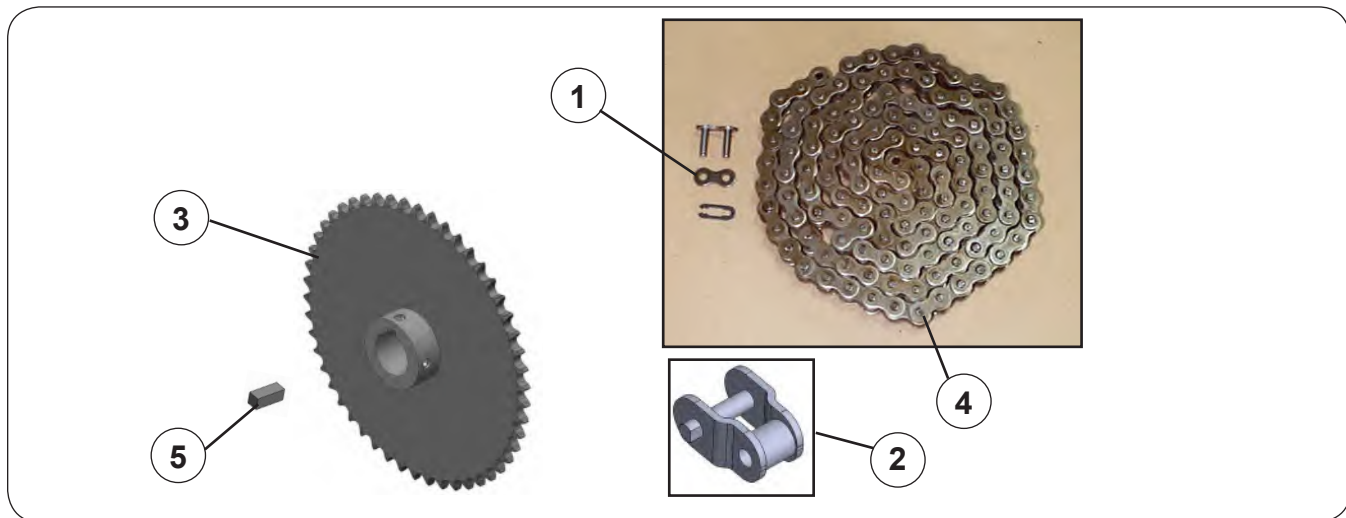

ITEM	PART NUMBER	DESCRIPTION	QTY	NOTES
1	JAP2112	Connecting Link #50 (Stainless Steel)	1	
2	JAP2113	Offset Link #50 (Stainless Steel)	1	
3	JAP2369	Sprocket Weldment with Hub, 1 1/2" Bore, 3/8" Keyway, Model 5050	1	
4	JAP2784	Roller Chain #50 (Single) 101 Links (Stainless Steel)	1	
5	JBM3526	Key, 3/8" x 3/8" x 1"	1	

Bottom Fill Plumbing Components

Please visit www.unverferth.com/parts/ for the most current parts listing.

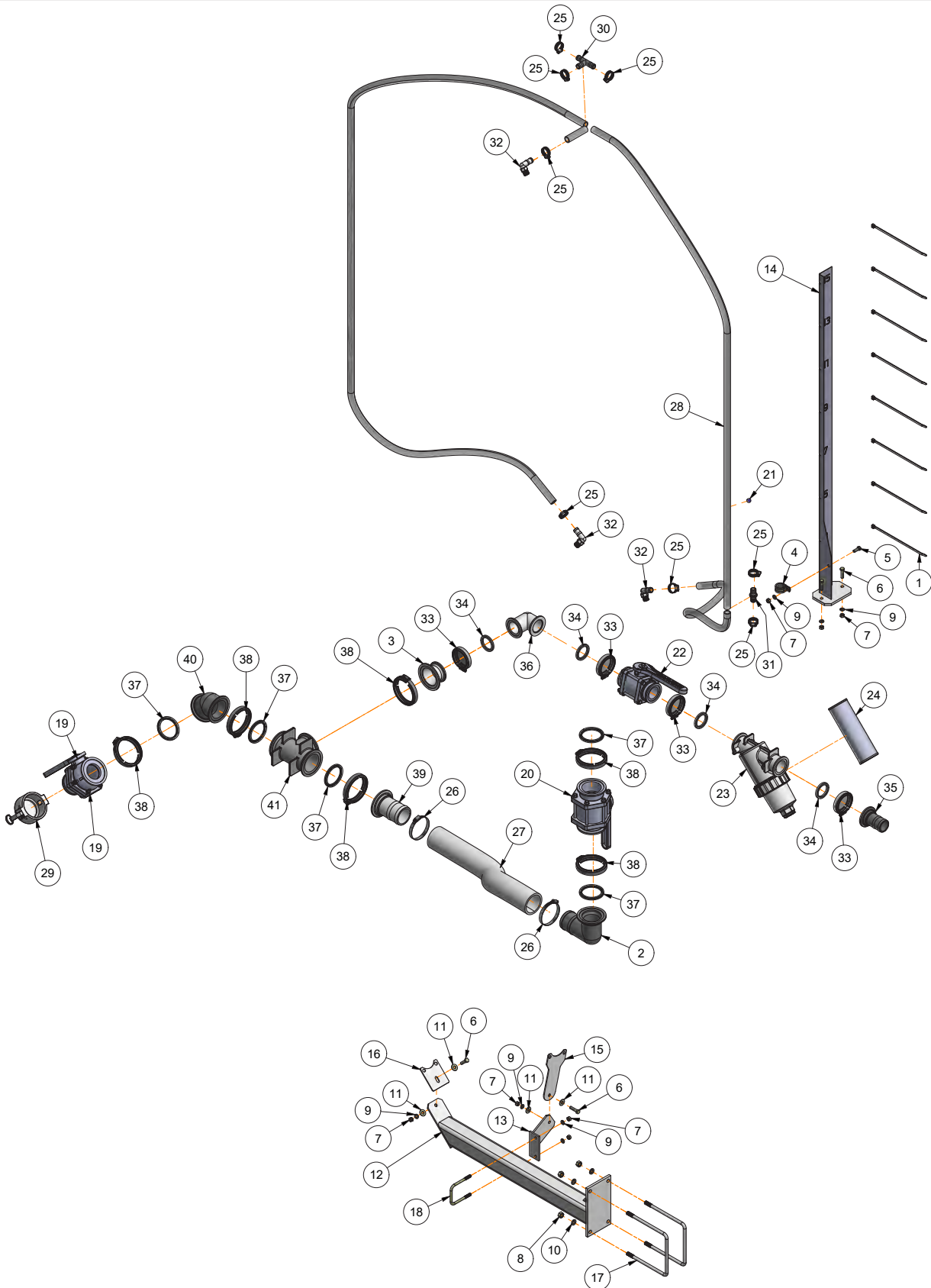

Bottom Fill Plumbing Components

Please visit www.unverferth.com/parts/ for the most current parts listing.

ITEM	PART NUMBER	DESCRIPTION	QTY	NOTES
1	9003735	Cable Tie 11"	8	
2	9005533	90° Elbow, 3" Flange x 3" Hose Barb	1	
3	9007455	Reducer Coupler, 3" Flange x 2" FP Flange	1	
4	9008246	Steel Clamp, 1 1/4" Dia. x 3/4"	1	
5	9390-055	Capscrew, 3/8"-16UNC x 1" G5	1	
6	9390-057	Capscrew, 3/8"-16UNC x 1 1/2" G5	4	
7	9394-006	Hex Nut, 3/8"-16UNC	7	
8	9394-010	Hex Nut, 1/2"-13UNC	4	
9	9404-021	Lock Washer, 3/8"	7	
10	9404-025	Lock Washer, 1/2"	4	
11	9405-076	Flat Washer, 3/8" USS	4	
12	JAM3659	Bottom Fill Valve Mounting Bracket Weldment	1	
13	JAM3660	Valve Support Bracket Weldment	1	
14	JAM3670	Tank Marking Bracket Weldment	1	
15	JAM3689	Valve Mounting Plate	1	
16	JAM4827	Fill Valve Support Plate	1	
17	JBP3356	U-Bolt, 1/2"-13UNC x 8 1/4", 7 9/16" C/C G5	2	
18	JBP3362	U-Bolt, 3/8"-16UNC x 4", 3 7/16" C/C G5	1	
19	JCP2064	90° Elbow, 3" Flange x 3" NPT Male Adapter	1	
20	JCP2076	Ball Valve, 3" Flange x 3" Flange	1	
21	JCP2684	Sight Tube Ball, 5/8" Dia. (Blue)	1	
22	JCP2705	Ball Valve, 2" Flange x 2" Flange	1	
23	JCP2706	Line Strainer, 2" Full Port, Flange Body & Cap, Less Screen	1	
24	JCP2707	30 Mesh Strainer Screen, 2" Full Port	1	
25	TA800912	Hose Clamp, 13/16" - 1 1/2" (SS) SAE #16	8	
26	TA800926	Hose Clamp - Worm Drive, 1 3/4" - 3 3/4" (SS) SC-52	2	
27	TA806334	Fertilizer Hose 3"	2.5 Ft.	
28	TA806558	3/4" Clear Vinyl Tubing	24 Ft.	
29	TA811816	Cap, 3" Quick-Disconnect	1	
30	TA814891	Hose Barb 3/4" Poly Tee	1	
31	TA814923	Hose Mender Poly 3/4" Hose	1	
32	TA814957	90° Elbow Hose Barb, 1/2"-14 NPTF Male x 3/4" Hose Shank	3	
33	TA816000	Clamp, 2" Full Port Flange	4	
34	TA816001	Gasket, 2" Full Port Flange	4	
35	TA816008	Hose Barb, 2" FP Flange	1	
36	TA816010	90° Elbow, 2" Flange Full Port x 2" Flange Full Port	1	
37	TA816038	Gasket, 3" EPDM	6	
38	TA816039	Clamp, Worm Screw, 3" Flange	6	
39	TA816047	Hose Barb 3" Flange x 3" Hose Shank	1	
40	TA816049	45° Coupler, 3" Flange x 3" Flange	1	
41	TA816051	Tee, 3" Flange x 3" Flange x 3" Flange	1	

AT4615 — Parts

ACE 205 Variable Rate Pump

Please visit www.unverferth.com/parts/ for the most current parts listing.

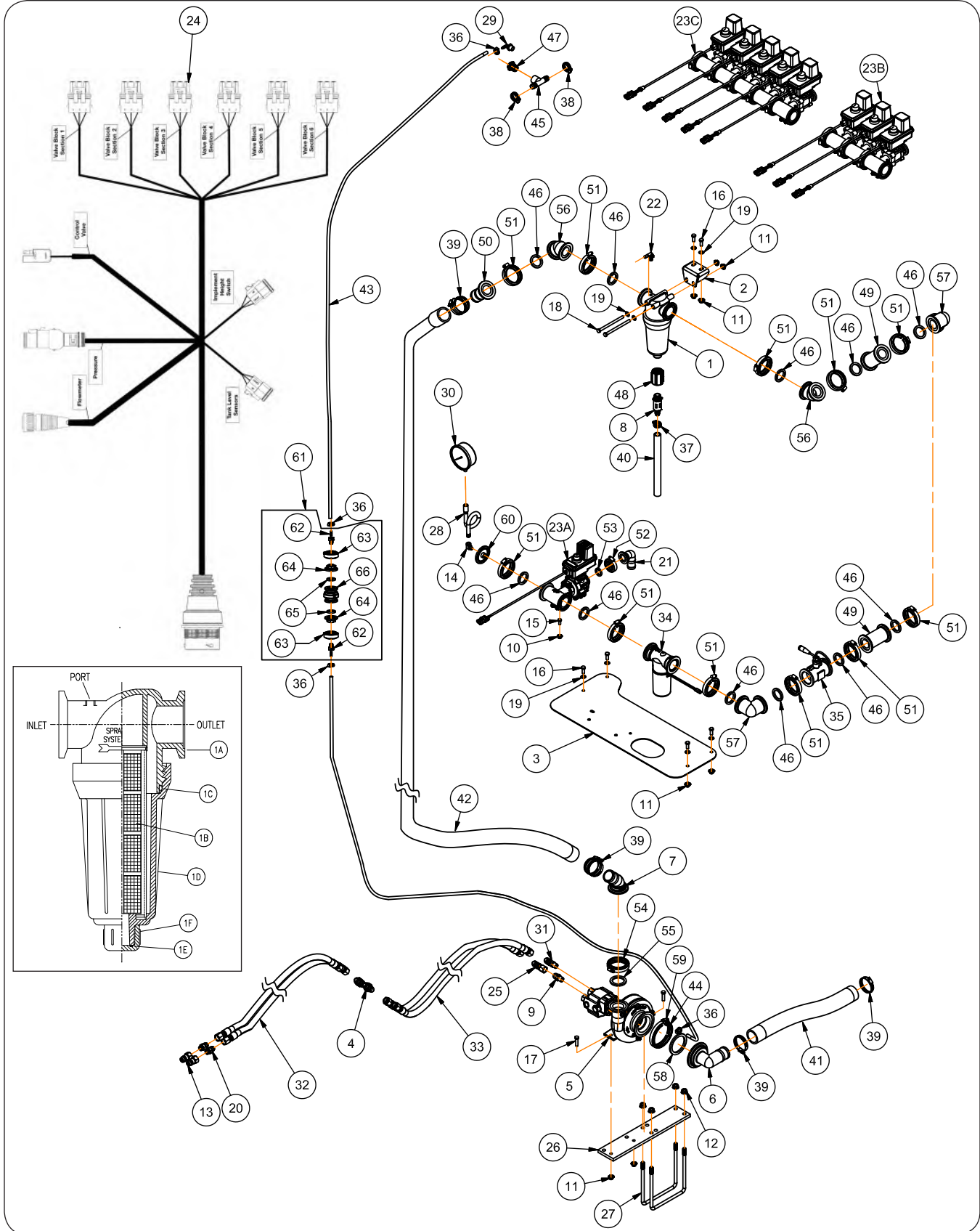

ACE 205 Variable Rate Pump

Please visit www.unverferth.com/parts/ for the most current parts listing.

ITEM	PART NUMBER	DESCRIPTION	QTY			NOTES
			1 Section	3 Section	5 Section	
1	402255	Strainer, 2" Flanged Line	1	1	1	Includes Items 1A-1F
1A	403257	Strainer Head	1	1	1	
1B	TA869070	Screen, 50 Mesh	1	1	1	
1C	TA867486	Gasket, EPDM	1	1	1	
1D	TA868842	Bowl, Polypropylene	1	1	1	
1E	TA868843	O-Ring, Viton	1	1	1	
1F	TA868844	Cap, Polypropylene	1	1	1	
2	44322B	Filter Mounting Bracket Weldment	1	1	1	
3	44445BB	Valve Mounting Bracket	1	1	1	
4	9005789	Union, Bulkhead 7/8"-14UNF	2	2	2	
5	9005841	ACE 205 Hydraulic Pump	1	1	1	
6	9005844	90° Elbow, 3" Flange x 2" Hose Barb	1	1	1	
7	9005845	45° Elbow, 2" Flange x 2" Hose Barb	1	1	1	
8	9007699	Valve-Poly, Micro, 3/4" MPT x 3/4" Hose Barb	1	1	1	
9	9123	Adapter, 7/8"-14 JIC Male x 1/2"-14 NPTF Male	1	1	1	
10	91257	Large Flange Hex Nut, 5/16"-18UNC	1	2	2	
11	91263	Large Flange Nut, 3/8"-16UNC	10	10	10	
12	91267	Flange Nut, 1/2"-13UNC	4	4	4	
13	91383	Male Tip Coupling 3/4"-16	2	2	2	
14	91432	90° Elbow, 1/4-18 NPTF Male x 1/4-18 NPTF Female	1	1	1	
15	9390-028	Capscrew, 5/16"-18UNC x 3/4" G5	1	2	2	
16	9390-055	Capscrew, 3/8"-16UNC x 1" G5	6	6	6	
17	9390-057	Capscrew, 3/8"-16UNC x 1 1/2" G5	2	2	2	
18	9390-070	Capscrew, 3/8"-16UNC x 5 1/2" G5	2	2	2	
19	9405-074	Flat Washer, 3/8" SAE	8	8	8	
20	9503026	Adapter, 7/8"-14 JIC Male x 3/4"-16 O-Ring Male	2	2	2	
21	TA815018	90° Elbow, 1" Flange x 1" Hose Barb	1	-	-	For Toolbars 42.5' & Smaller
			-	3	-	For Toolbars Over 42.5'
	9503462	90° Elbow, 1" Flange x 1 1/4" Hose Barb	1	-	-	For Toolbars Over 42.5'
	TA815017	90° Elbow, 1" Flange x 3/4" Hose Barb	-	3	-	For Toolbars 42.5' & Smaller
	TA815017	90° Elbow, 1" Flange x 3/4" Hose Barb	-	-	3	For All Size Toolbars
TA815012	Hose Barb, 1" Flange x 3/4" Hose Shank (NOT SHOWN)	-	-	2		
22	9503463	90° Elbow, 1/4"-18 NPTF Male x 3/8" Hose Barb	1	1	1	
23A	9503464	Ball Valve Flanged Single 490 Series	1	-	-	See "Ball Valve Components"
23B	TA854833	Ball Valve Flanged 450 BEC (3-Section)	-	1	-	
23C	TA854835	Ball Valve Flanged 450 BEC (5-Section)	-	-	1	
24	9503472	Wire Harness 6 Ft. Flow Cable	1	1	1	
25	96559	90° Elbow, 7/8"-14 JIC Male x 7/8"-14 JIC Female	1	1	1	
26	JAM3672	Centrifugal Pump Mounting Plate	1	1	1	

(continued on next page)

AT4615 — Parts

ACE 205 Variable Rate Pump (continued)

Please visit www.unverferth.com/parts/ for the most current parts listing.

ITEM	PART NUMBER	DESCRIPTION	QTY			NOTES
			1 Section	3 Section	5 Section	
27	JBP3356	U-Bolt, 1/2"-13UNC x 8 1/4", 7 9/16" C/C G5	2	2	2	
28	JCP1999	Pigtail Gauge Protector	1	1	1	
29	JCP2085	90° Elbow, 1/2"-14 NPT Male x 1/4" Hose Barb	1	1	1	
30	JCP2575	Gauge 4" Liquid Filled (SS)	1	1	1	
31	JDP4016	90° Elbow, 7/16"-14 JIC Male x 1/2"-14 NPTF Male	1	1	1	
32	JDP5281	Hose, 5/8" Dia. x 84" (2 Wire)	2	2	2	
33	JDP5353	Hose, 5/8" Dia. x 132" (2 Wire)	2	2	2	
34	TA720258	Flow Control Valve 1"	1	1	1	For Toolbars 42.5' & Smaller
	TA720260	Flow Control Valve 1.5"				For Toolbars Over 42.5'
35	TA720365	Flow Meter Complete	1	1	1	
36	TA800902	Hose Clamp 7/8", M-6 (SS)	2	2	2	
37	TA800910	Hose Clamp 1/2" (SS)	1	1	1	
38	TA800912	Hose Clamp 13/16" - 1 1/2" (SS)	2	2	2	
39	TA800922	Worm Drive Hose Clamp (3/4" - 2 5/8") (SS)	6	6	6	
40	TA806250	Hose, 3/4" Dia. x 12" EPDM	1 Ft.	1 Ft.	1 Ft.	
41	TA806328	Hose, 2" EPDM, 200 PSI	4 Ft.	4 Ft.	4 Ft.	
42	TA806332	2" Fertilizer Solution Hose	2 Ft.	2 Ft.	2 Ft.	
43	TA806420	14 1/4" EVA Hose	15 Ft.	15 Ft.	15 Ft.	
44	TA810040	Hose Barb, 1/8" MPT x 1/4" Hose Shank	1	1	1	
45	TA810494	Tee, 3/4"-14 NPT Female x 3/4" HB x 3/4" HB	1	1	1	
46	TA811944	Gasket, 2 3/16" OD x 1 5/8" ID x .25"	11	13	15	
47	TA814653	Reducer Bushing Poly, 3/4-14NPTF Male x 1/2-14NPTF Female	1	1	1	
48	TA814710	Reducer Coupling 1" x 3/4"	1	1	1	
49	TA815003	Coupling Poly, 2" Flange x 2" Flange	2	2	2	
50	TA815016	Hose Barb, 2" Flange x 2" Hose Shank	1	1	1	
51	TA815025	2" Worm Screw Flange Clamp	11	13	15	
52	TA815026	Flange Clamp 1" Worm Screw	1	3	5	
53	TA815029	Gasket/Seal 1 3/8" x 1" x 1/4"	1	3	5	
54	TA816000	Clamp 2" Full Port Flange	1	1	1	
55	TA816001	Gasket 2" Full Port Flange	1	1	1	
56	TA816004	45° Elbow, 2" Flange x 2" Flange	2	2	2	
57	TA816017	90° Elbow, 2" Flange x 2" Flange	2	2	2	
58	TA816038	Gasket, 3"	1	1	1	
59	TA816039	Clamp Worm Screw, 3" Flange	1	1	1	
60	TA883114	Plug, 2" Flanged w/ 1/4" FPT Gauge Port	1	1	1	
61	46003	Air Vent Assembly	1	1	1	Includes Items 62-66
62	TA814845	Hose Barb, 1/4-18 NPTF x 1/4" Hose Shank	2	2	2	
63	TA815026	Flange Clamp 1" Worm Screw	2	2	2	
64	9504009	Manifold Flange Plug, 1" x 1/4-18 NPTF Female	2	2	2	
65	TA815029	Gasket/Seal 1 3/8" x 1" x 1/4"	2	2	2	
66	9007339	Flange Check Valve, 1"	1	1	1	

Ball Valve Components

Please visit www.unverferth.com/parts/ for the most current parts listing.

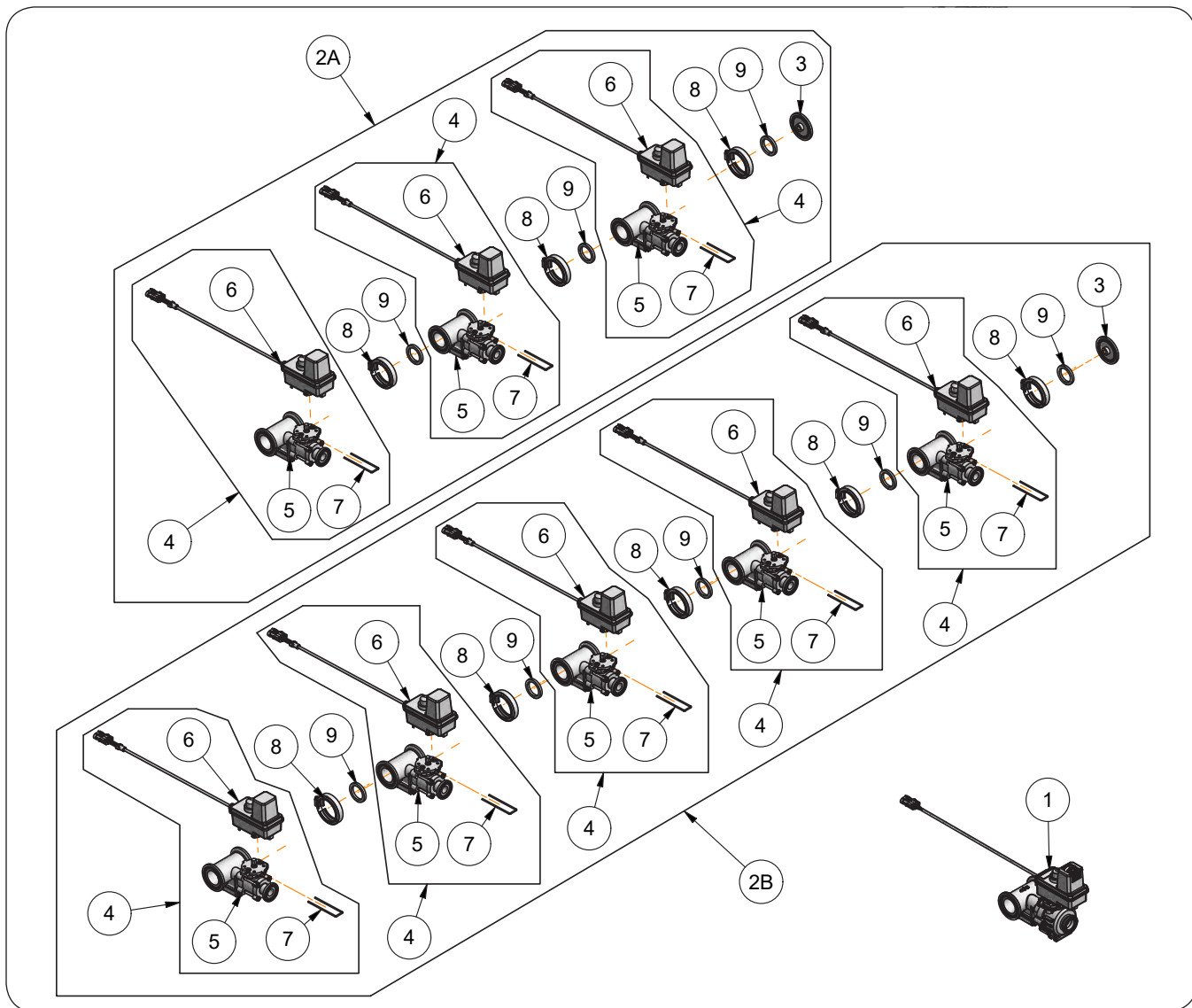

ITEM	PART NUMBER	DESCRIPTION	QTY			NOTES
			1 Section	3 Section	5 Section	
1	9503464	Ball Valve Flanged Single 490 Series	1	-	-	
2A	TA854833	Ball Valve Flanged 450 BEC (3-Section)	-	1	-	Includes Items 3-9
2B	TA854835	Ball Valve Flanged 450 BEC (5-Section)	-	-	1	Includes Items 3-9
3	TA883114	Plug, 2" Flanged w/ 1/4" FPT Gauge Port	-	1	1	
4	TA854831	Ball Valve, Flanged 440/450 Single	-	3	5	Includes Items 5-7
5	901998	Ball Valve Assembly	-	1	1	
6	TA854874	Shutoff Ball Valve Motor Head	-	1	1	
7	TA854875	Retainer Clip	-	1	1	
8	TA815025	Worm Screw Flange Clamp 2"	-	3	5	
9	TA811944	Gasket, 2 3/16" OD x 1 5/8" ID	-	3	5	

Manifold Components

Please visit www.unverferth.com/parts/ for the most current parts listing.

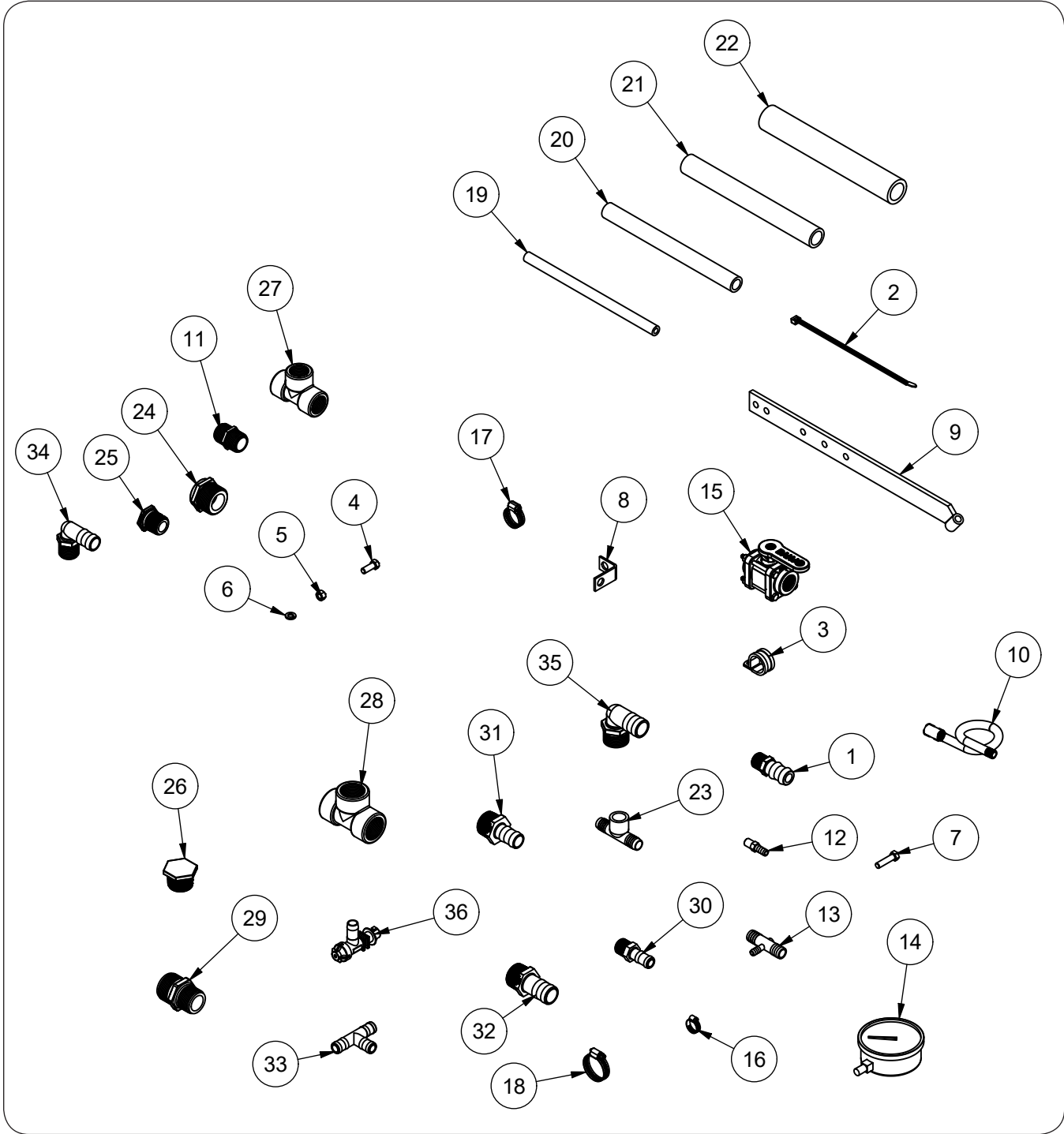

Manifold Components

Please visit www.unverferth.com/parts/ for the most current parts listing.

ITEM	PART NUMBER	DESCRIPTION	QTY							
			15 Row 30"	17 Row 30"	23 Row 30"	25 Row 20"	25 Row 30"	27 Row 18"	33 Row 15"	35 Row 20"
1	TA814863	Hose Barb 1", 3/4-14 ANS Blunt Start Taper Pipe	1	1	2	1	2	1	1	2
2	9003735	Cable Tie 11"	15	17	23	25	25	27	33	37
3	9008246	Steel Clamp, 1 1/4" Dia. x 3/4"	19	21	23	25	25	31	37	35
4	900900-055	Capscrew, 3/8"-16UNC x 1" (SS)	15	17	23	25	25	27	33	35
5	900901-006	Hex Nut, 3/8"-16UNC (SS)	17	19	25	27	27	29	35	37
6	900903-021	Lock Washer, 3/8" (SS)	17	19	25	27	27	29	35	37
7	9390-057	Capscrew, 3/8"-16UNC x 1 1/2" G5	2	2	2	2	2	2	2	2
8	JAM3628	Mounting Bracket Strip	15	17	23	25	25	27	33	35
9	JCM2221	NH3 Gauge Holder	1	1	1	1	1	1	1	1
10	JCP1999	Pigtail Gauge Protector	1	1	1	1	1	1	1	1
11	TA814610	Nipple 1-11 1/2 NPT Male x 2 (Short)	1	1	-	1	-	1	1	-
12	JCP2308	Hose Barb 1/4 NPT Male x 3/8 Hose	1	1	1	1	1	1	1	1
13	JCP2470	Hose Barb Tee 3/8" Hose Barb x 3/4" Hose Barb x 3/4" Hose Barb	1	1	1	1	1	1	1	1
14	JCP2575	Gauge 4" Liquid Filled (SS)	1	1	1	1	1	1	1	1
15	JCP2576	Ball Valve, 3/4" FP	2	2	2	-	2	-	-	2
16	TA800902	Hose Clamp 7/8", M-6 (SS)	2	2	2	2	2	2	2	2
17	TA800912	Hose Clamp 13/16" - 1 1/2" (SS)	38	38	62	58	66	58	70	86
18	TA800916	Hose Clamp 1" - 2" (SS)	-	-	2	-	2	-	-	2
19	TA806200	Hose, 3/8" Dia. x 12" EPDM	10	10	10	10	10	10	10	10
20	TA806250	Hose, 3/4" Dia. x 12" EPDM	45	47.5	75	53	80	53	53	80
21	TA806275	Hose, 1" Dia. x 12" EPDM	6	6	33	6	33	6	6	33
22	TA806300	Hose 1 1/4" Dia. x " EPDM	-	-	6	-	6	-	-	6
23	TA810494	Tee, 3/4"-14 NPT Female x 3/4" Hose Barb x 3/4" Hose Barb	1	1	2	1	2	1	1	2
24	TA814661	Reducer Bushing, 1 1/2-11 1/2 NPTF Male x 1-11 1/2 NPTF Female	1	1	-	1	-	1	1	-
25	TA814752	Plug, 1"-11 1/2 NPTF Male	1	1	-	1	-	1	1	-
26	TA814753	Plug, 1 1/4"-11 1/2 NPTF Male	-	-	1	-	1	-	-	1
27	TA814782	Tee, 1"-11 1/2 NPTF Female x 1"-11 1/2 NPTF Female x 1"-11 1/2 NPTF Female	1	1	-	1	-	1	1	-
28	TA814783	Tee, 1 1/4"-11 1/2 NPT Female x 1 1/4"-11 1/2 NPT Female x 1 1/4"-11 1/2 NPT Female	-	-	2	-	2	-	-	2
29	TA814825	Reducer Nipple, 1 1/2"-11 1/2 NPT Male x 1 1/4"-11 1/2 NPT Male	-	-	1	-	1	-	-	1
30	TA814861	Hose Barb 3/4"-14 MPT x 3/4" Hose Shank	4	4	4	-	4	-	-	4
31	TA814871	Hose Barb 1 1/4"-11 1/2 MPT x 1" Hose Shank	-	-	2	-	2	-	-	2
32	TA814872	Hose Barb 1 1/4"-11 1/2 MPT x 1 1/4" Hose Shank	-	-	1	-	1	-	-	1
33	TA814891	Hose Barb 3/4" Poly Tee	-	-	2	2	2	-	-	2
34	TA814966	90° Elbow, 1"-11 1/2 NPTF Male x 1" Hose Shank	1	1	-	1	-	1	1	-
35	TA814972	90° Elbow, 1 1/4"-11 1/2 NPTF Male x 1 1/4" Hose Shank	-	-	1	-	1	-	-	1
36	TA886010	Nozzle, Single QJ 3/4" Elbow Sprayer Boom Nozzle Body	2	2	4	4	4	2	2	4

Manifold Components — Gauge & Mounting Components

Please visit www.unverferth.com/parts/ for the most current parts listing.

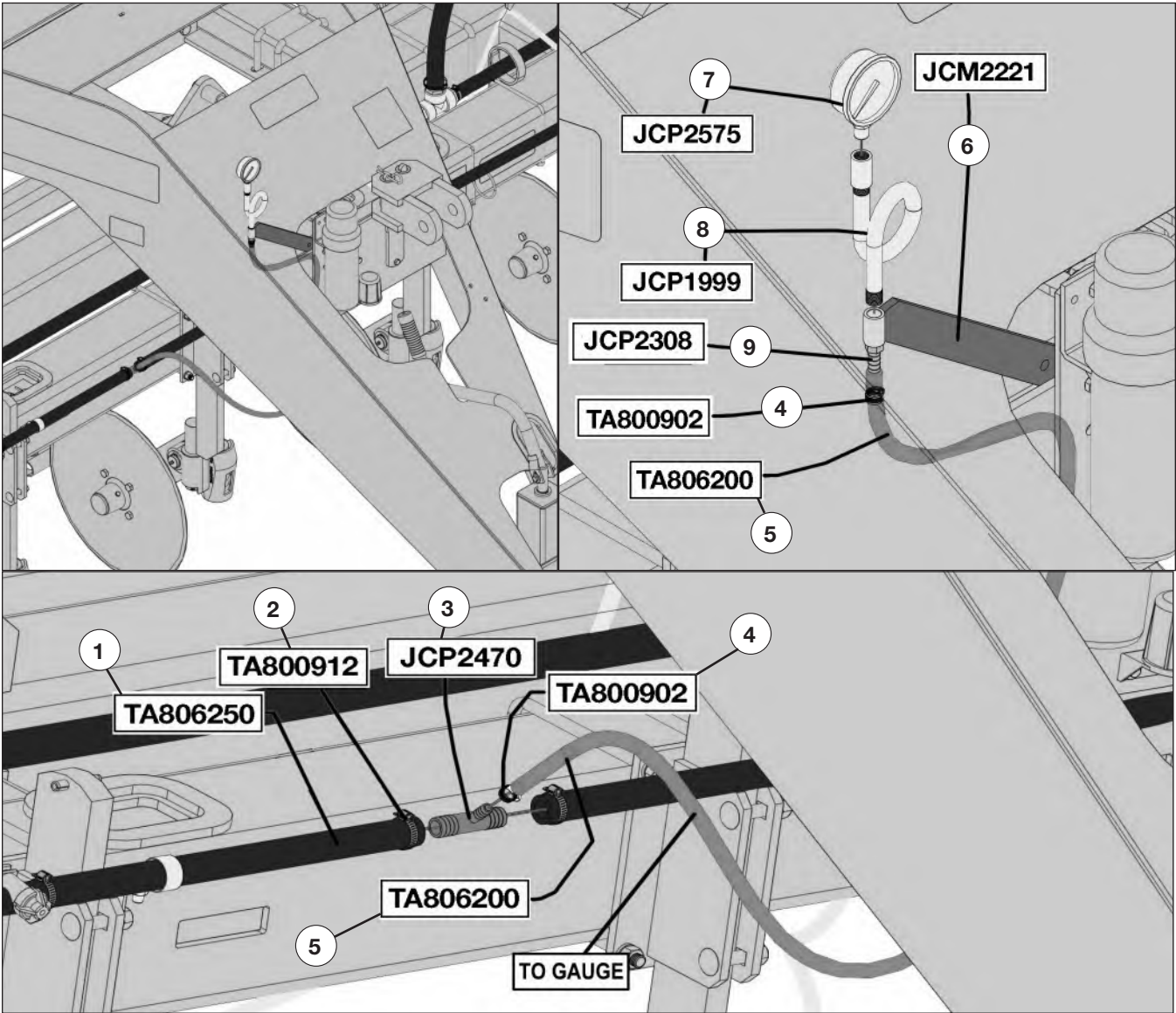

Manifold Components — Gauge & Mounting Components

Please visit www.unverferth.com/parts/ for the most current parts listing.

ITEM	PART NUMBER	DESCRIPTION	QTY							
			15 Row 30"	17 Row 30"	23 Row 30"	25 Row 20"	25 Row 30"	27 Row 18"	33 Row 15"	35 Row 20"
1	TA806250	Hose, 3/4" Dia. x 12" EPDM	45	47.5	75	53	80	53	53	80
2	TA800912	Hose Clamp 13/16" - 1 1/2" (SS)	38	38	62	58	66	58	70	86
3	JCP2470	Hose Barb Tee 3/8" Hose Barb x 3/4" Hose Barb x 3/4" Hose Barb	1	1	1	1	1	1	1	1
4	TA800902	Hose Clamp 7/8", M-6 (SS)	2	2	2	2	2	2	2	2
5	TA806200	Hose, 3/8" Dia. x 12" EPDM	10	10	10	10	10	10	10	10
6	JCM2221	NH3 Gauge Holder	1	1	1	1	1	1	1	1
7	JCP2575	Gauge 4" Liquid Filled (SS)	1	1	1	1	1	1	1	1
8	JCP1999	Pigtail Gauge Protector	1	1	1	1	1	1	1	1
9	JCP2308	Hose Barb 1/4 NPT Male x 3/8 Hose	1	1	1	1	1	1	1	1

Manifold Layout — Drive Pump, Fittings & Hoses
(Double Tube Toolbar)

Please visit www.unverferth.com/parts/ for the most current parts listing.

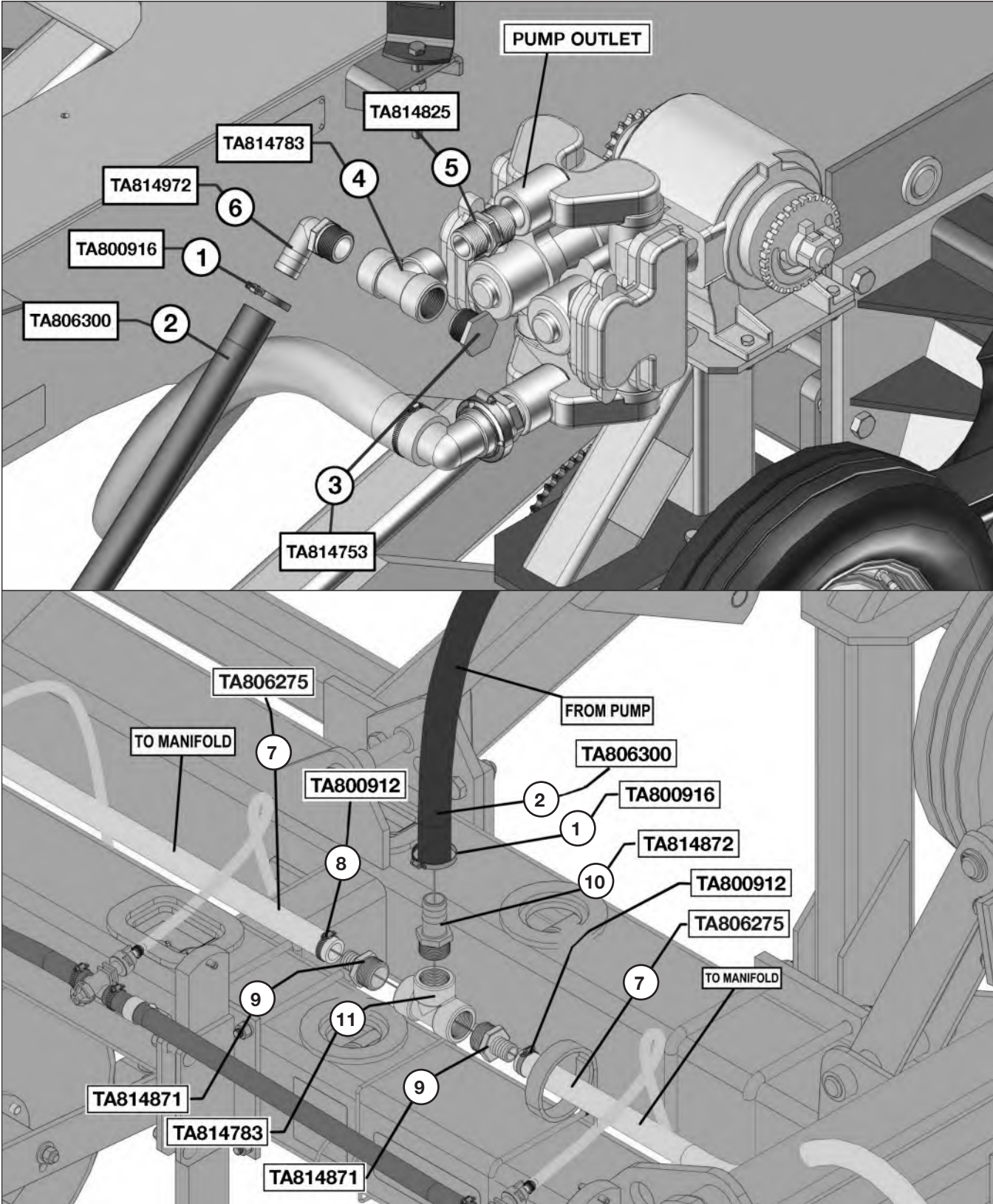

**Manifold Layout — Drive Pump, Fittings & Hoses
(Double Tube Toolbar)**

Please visit www.unverferth.com/parts/ for the most current parts listing.

ITEM	PART NUMBER	DESCRIPTION	QTY		
			23 Row 30"	25 Row 30"	35 Row 20"
1	TA800916	Hose Clamp 1" - 2" (SS)	2	2	2
2	TA806300	Hose 1 1/4" Dia. x " EPDM	6	6	6
3	TA814753	Plug, 1 1/4"-11 1/2 NPTF Male	1	1	1
4	TA814783	Tee, 1 1/4"-11 1/2 NPT Female x 1 1/4"-11 1/2 NPT Female x 1 1/4"-11 1/2 NPT Female	2	2	2
5	TA814825	Reducer Nipple, 1 1/2"-11 1/2 NPT Male x 1 1/4"-11 1/2 NPT Male	1	1	1
6	TA814972	90° Elbow, 1 1/4"-11 1/2 NPTF Male x 1 1/4" Hose Shank	1	1	1
7	TA806275	Hose, 1" Dia. x 12" EPDM	33	33	33
8	TA800912	Hose Clamp 13/16" - 1 1/2" (SS)	62	66	86
9	TA814871	Hose Barb 1 1/4"-11 1/2 MPT x 1" Hose Shank	2	2	2
10	TA814872	Hose Barb 1 1/4"-11 1/2 MPT x 1 1/4" Hose Shank	1	1	1
11	TA814783	Tee, 1 1/4"-11 1/2 NPT Female x 1 1/4"-11 1/2 NPT Female x 1 1/4"-11 1/2 NPT Female	2	2	2

Manifold Layout — Drive Pump, Fittings & Hoses
(Single Tube Toolbar)

Please visit www.unverferth.com/parts/ for the most current parts listing.

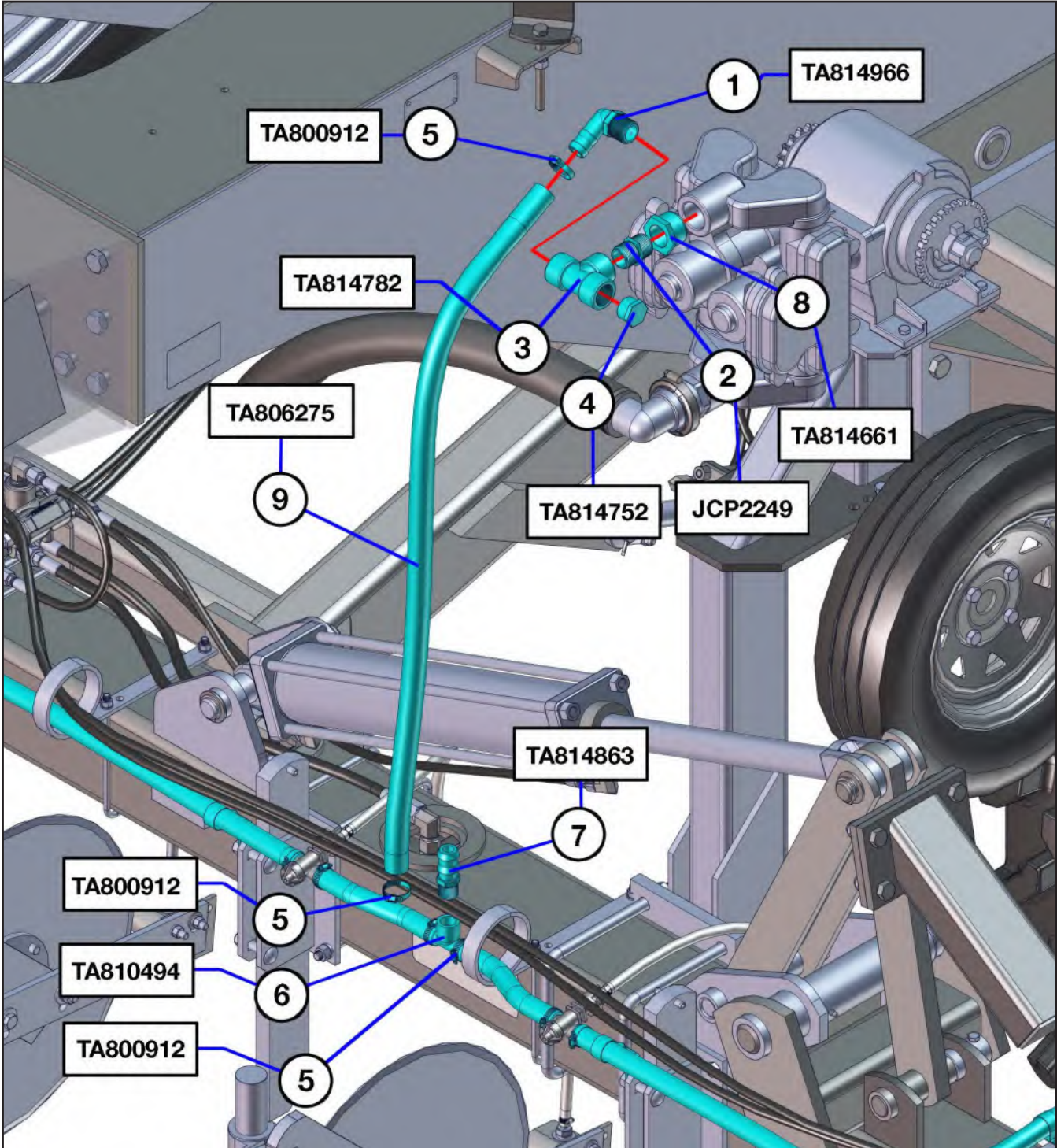

**Manifold Layout — Drive Pump, Fittings & Hoses
(Single Tube Toolbar)**

Please visit www.unverferth.com/parts/ for the most current parts listing.

ITEM	PART NUMBER	DESCRIPTION	QTY				
			15 Row 30"	17 Row 30"	25 Row 20"	27 Row 18"	33 Row 15"
1	TA814966	90° Elbow, 1"-11 1/2 NPTF Male x 1" Hose Shank	1	1	1	1	1
2	JCP2249	Nipple 1-11 1/2 NPT Male x 2 (Close)	1	1	1	1	1
3	TA814782	Tee, 1"-11 1/2 NPTF Female x 1"-11 1/2 NPTF Female x 1"-11 1/2 NPTF Female	1	1	1	1	1
4	TA814752	Plug, 1"-11 1/2 NPTF Male	1	1	1	1	1
5	TA800912	Hose Clamp 13/16" - 1 1/2" (SS)	38	38	58	58	70
6	TA810494	Tee, 3/4"-14 NPT Female x 3/4" Hose Barb x 3/4" Hose Barb	1	1	1	1	1
7	TA814863	Hose Barb 1", 3/4-14 ANS Blunt Start Taper Pipe	1	1	1	1	1
8	TA814661	Reducer Bushing, 1 1/2-11 1/2 NPTF Male x 1-11 1/2 NPTF Female	1	1	1	1	1
9	TA806275	Hose, 1" Dia. x 12" EPDM	6	6	6	6	6

Manifold Layout — 23 Row Coultter Assembly Fittings and Hoses

Please visit www.unverferth.com/parts/ for the most current parts listing.

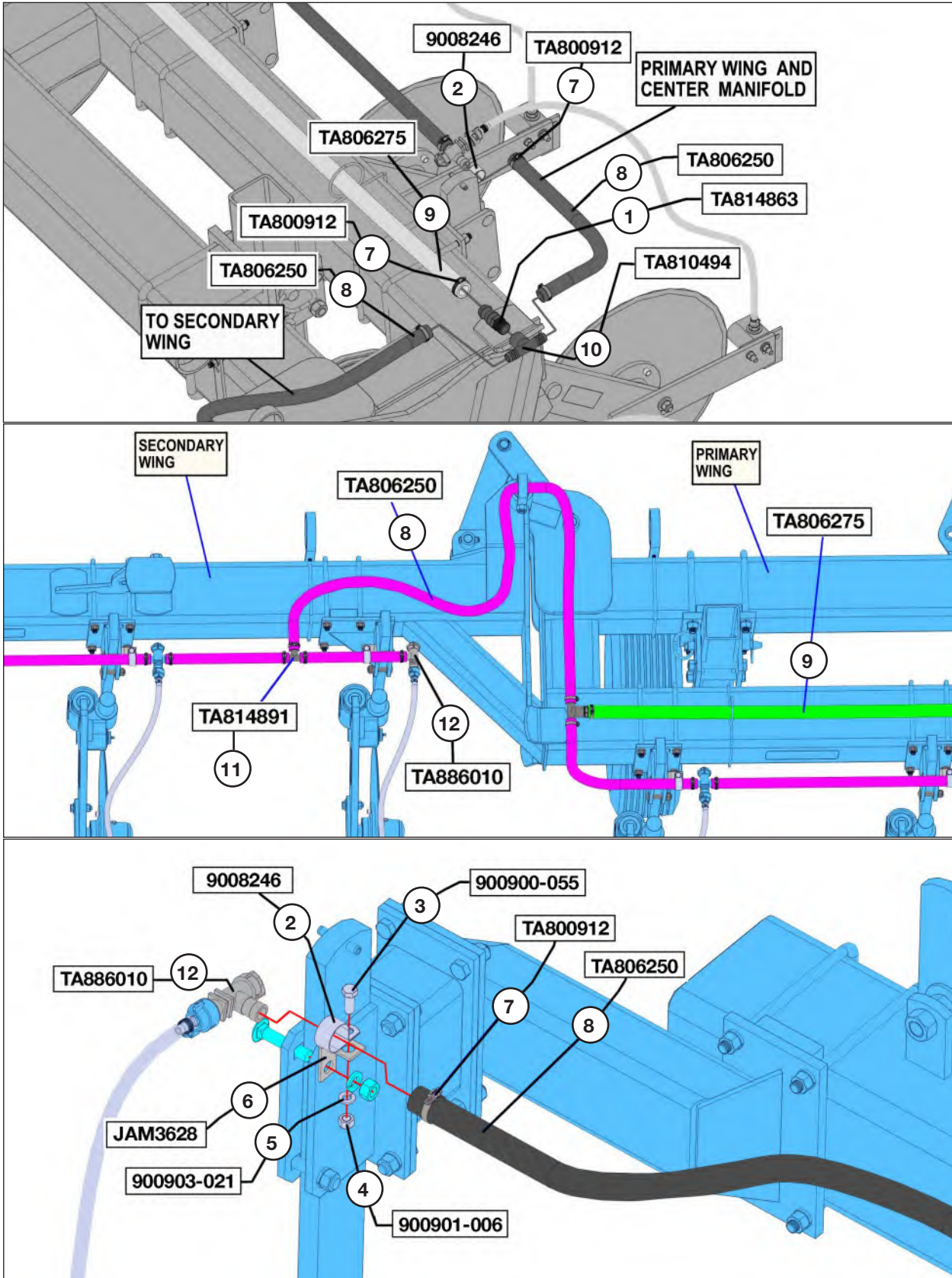

Manifold Layout — 23 Row Coulter Assembly Fittings and Hoses

Please visit www.unverferth.com/parts/ for the most current parts listing.

ITEM	PART NUMBER	DESCRIPTION	QTY
1	TA814863	Hose Barb 1", 3/4-14 ANS Blunt Start Taper Pipe	2
2	9008246	Steel Clamp, 1 1/4" Dia. x 3/4"	23
3	900900-055	Capscrew, 3/8"-16UNC x 1" (SS)	23
4	900901-006	Hex Nut, 3/8"-16UNC (SS)	25
5	900903-021	Lock Washer, 3/8" (SS)	25
6	JAM3628	Mounting Bracket Strip	23
7	TA800912	Hose Clamp 13/16" - 1 1/2" (SS)	62
8	TA806250	Hose, 3/4" Dia. x 12" EPDM	75
9	TA806275	Hose, 1" Dia. x 12" EPDM	33
10	TA810494	Tee, 3/4"-14 NPT Female x 3/4" Hose Barb x 3/4" Hose Barb	2
11	TA814891	Hose Barb 3/4" Poly Tee	2
12	TA886010	Nozzle, Single QJ 3/4" Elbow Sprayer Boom Nozzle Body	4

Manifold Layout — 25 Row Coulter Assembly Fittings and Hoses

Please visit www.unverferth.com/parts/ for the most current parts listing.

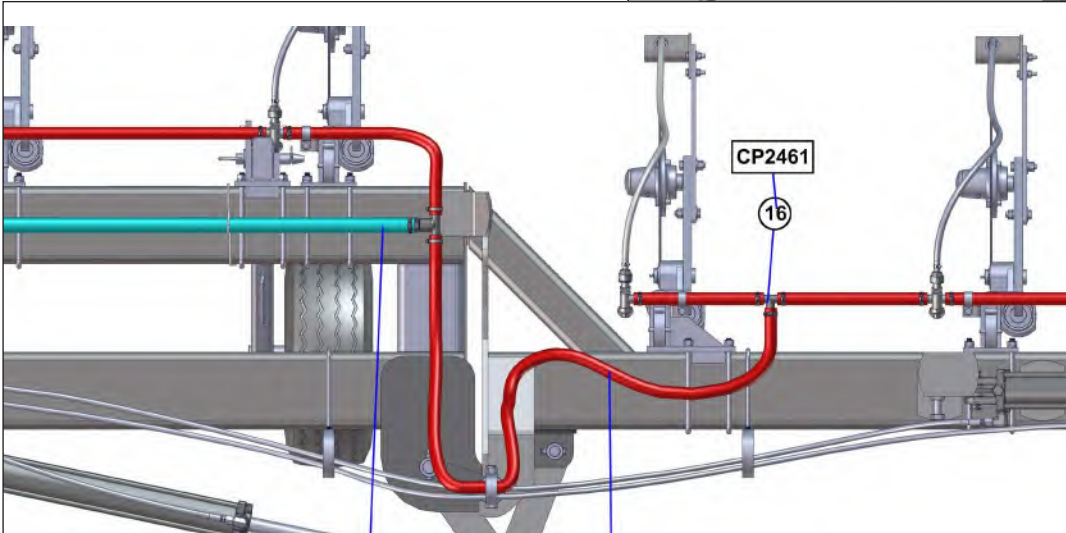
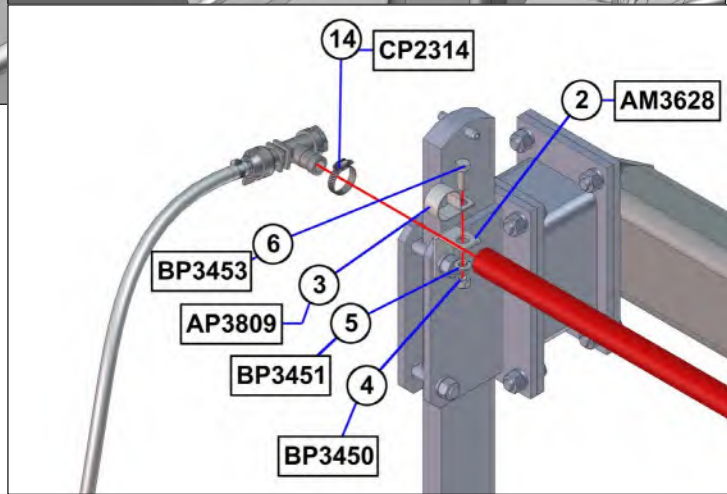
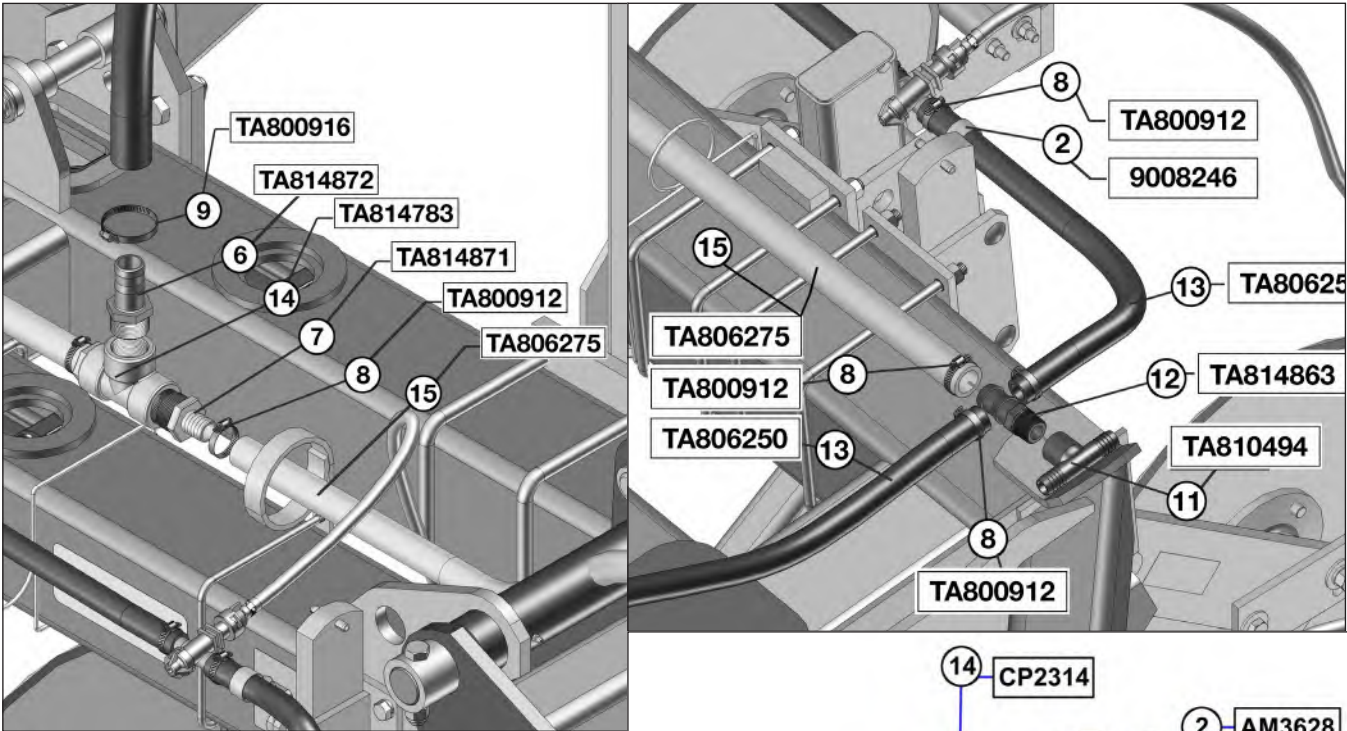

Manifold Layout — 25 Row Coulter Assembly Fittings and Hoses

Please visit www.unverferth.com/parts/ for the most current parts listing.

ITEM	PART NUMBER	DESCRIPTION	QTY
1	JAM3628	Mounting Bracket Strip	25
2	9008246	Steel Clamp, 1 1/4" Dia. x 3/4"	25
3	900901-006	Hex Nut, 3/8"-16UNC (SS)	27
4	900903-021	Lock Washer, 3/8" (SS)	27
5	900900-055	Capscrew, 3/8"-16UNC x 1" (SS)	25
6	TA814872	Hose Barb 1 1/4"-11 1/2 MPT x 1 1/4" Hose Shank	1
7	TA814871	Hose Barb 1 1/4"-11 1/2 MPT x 1" Hose Shank	2
8	TA800912	Hose Clamp 13/16" - 1 1/2" (SS)	66
9	TA800916	Hose Clamp 1" - 2" (SS)	2
10	TA814891	Hose Barb 3/4" Poly Tee	2
11	TA810494	Tee, 3/4"-14 NPT Female x 3/4" Hose Barb x 3/4" Hose Barb	2
12	TA814863	Hose Barb 1", 3/4-14 ANS Blunt Start Taper Pipe	2
13	TA806250	Hose, 3/4" Dia. x 12" EPDM	80
14	TA814783	Tee, 1 1/4"-11 1/2 NPT Female x 1 1/4"-11 1/2 NPT Female x 1 1/4"-11 1/2 NPT Female	2
15	TA806275	Hose, 1" Dia. x 12" EPDM	33

Controller Components

Please visit www.unverferth.com/parts/ for the most current parts listing.

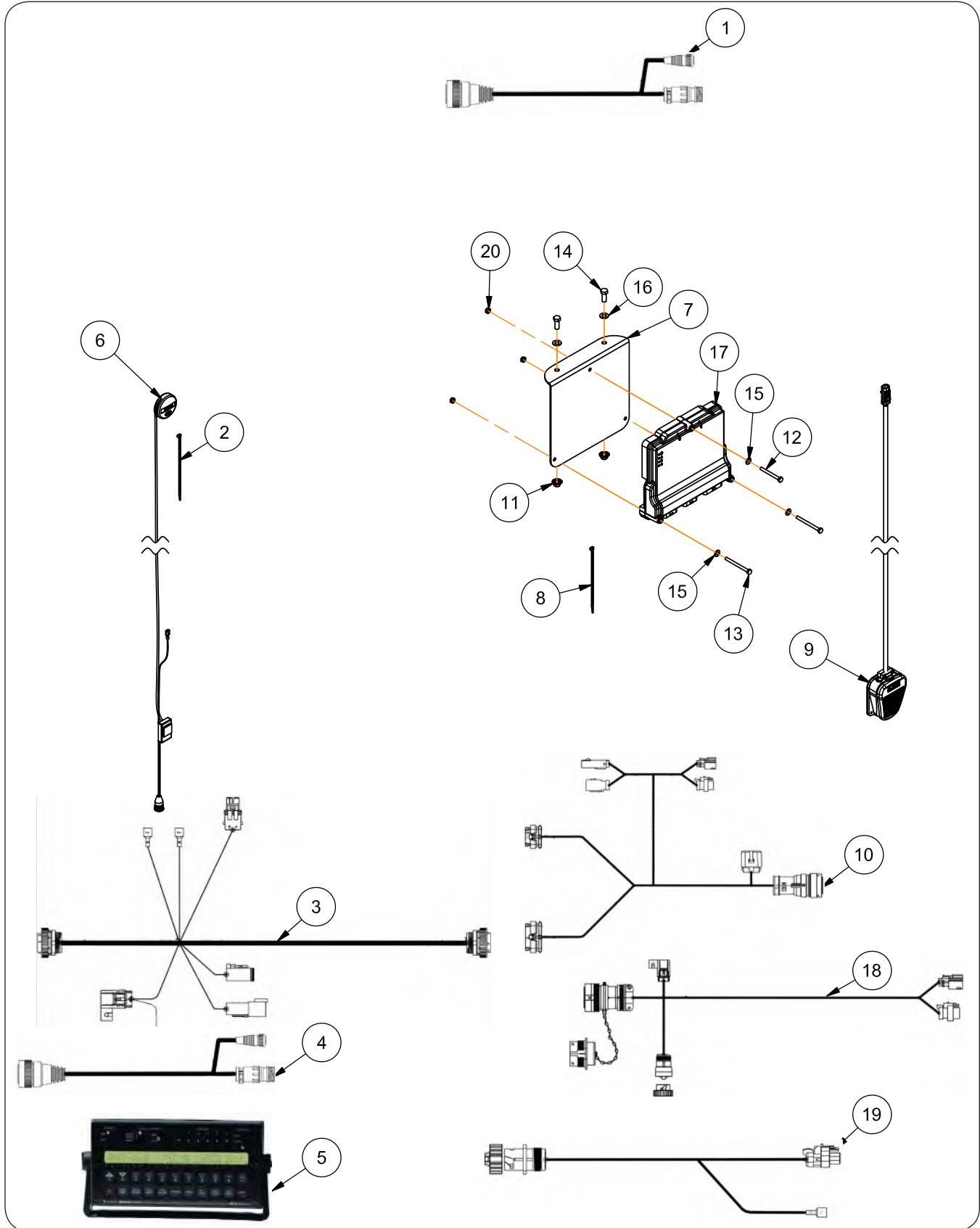

Controller Components

Please visit www.unverferth.com/parts/ for the most current parts listing.

ITEM	PART NUMBER	DESCRIPTION	QTY	NOTES
1	9503471	Wire Harness 30 Ft. 16-Pin Console to 47-Pin Connector	1	Less Rate Controller
2	9000106	Cable Tie 7 1/2"	6	Raven 450 Controller
3	9007549	Console Harness (450 Controller)	1	
4	9503471	Wire Harness 30 Ft. 16-Pin Console to 47-Pin Connector	1	
5	TA720315	Control Console, Raven SCS 450	1	
6	TA723025	Astro GPS Speed Sensor w/3-Pin Raven Conxall	1	
7	44440B	Mounting Bracket Plate	1	
8	9000106	Cable Tie 7 1/2"	6	
9	9005916	Foot Switch, ISO Node w/Harness	1	
10	9008095	Wire Harness, RCM ECU 47 Pin Rate	1	
11	91263	Nut/Large Flange, 3/8"-16UNC	2	
12	9390-011	Capscrew, 1/4"-20UNC x 2 1/2" G5	1	
13	9390-013	Capscrew, 1/4"-20UNC x 3" G5	2	
14	9390-055	Capscrew, 3/8"-16UNC x 1" G5	2	
15	9405-062	Flat Washer, 1/4" SAE	3	
16	9405-074	Flat Washer, 3/8" SAE	2	
17	9503386	Rate Control Module NH3	1	
18	9503387	Wire Harness, 12 Ft. Adapter 9-Pin IBIC to Gen 1, Hitch Cable	1	
19	9503390	Wire Harness, Foot Switch 23 Ft.	1	
20	9936	Lock Nut, 1/4"-20UNC	3	



Unverferth[®]
Manufacturing Company, Inc.

www.unverferth.com